



**AGENDA**  
**CUYAHOGA COUNTY COUNCIL REGULAR MEETING**  
**TUESDAY, NOVEMBER 9, 2021**  
**CUYAHOGA COUNTY ADMINISTRATIVE HEADQUARTERS**  
**C. ELLEN CONNALLY COUNCIL CHAMBERS – 4<sup>TH</sup> FLOOR**  
**5:00 PM**

- 1. CALL TO ORDER**
- 2. ROLL CALL**
- 3. PLEDGE OF ALLEGIANCE**
- 4. SILENT MEDITATION**
- 5. PUBLIC COMMENT**
- 6. APPROVAL OF MINUTES**
  - a) October 25, 2021 Committee of the Whole Meeting [See Page 9]
  - b) October 26, 2021 Committee of the Whole Meeting [See Page 13]
  - c) November 1, 2021 Committee of the Whole Meeting [See Page 15]
  - d) October 26, 2021 Regular Meeting [See Page 19]
- 7. ANNOUNCEMENTS FROM THE COUNCIL PRESIDENT**
- 8. MESSAGES FROM THE COUNTY EXECUTIVE**
- 9. LEGISLATION INTRODUCED BY EXECUTIVE**
  - a) **CONSIDERATION OF RESOLUTIONS FOR FIRST READING ADOPTION UNDER SUSPENSION OF RULES**
    - 1) R2021-0248: A Resolution amending the 2020/2021 Biennial Operating Budget for 2021 by providing for additional fiscal

appropriations from the General Fund and other funding sources, for appropriation transfers between budget accounts and for cash transfers between budgetary funds, to meet the budgetary needs of various County departments, offices and agencies, amending Resolution No. R2021-0228 dated 10/12/2021; and declaring the necessity that this Resolution become immediately effective. [See Page 35]

Sponsor: County Executive Budish/Fiscal Officer/Office of Budget and Management

- 2) R2021-0249: A Resolution approving a Collective Bargaining Agreement between Cuyahoga County and Laborers' International Union of North America, Local 860, representing approximately 68 employees in 3 classifications in the Department of Public Works/Sanitary Sewer Division for the period 1/1/2021 - 12/31/2023; directing that funds necessary to implement the Collective Bargaining Agreement be budgeted and appropriated; authorizing the County Executive to execute the agreement and all other documents consistent with this Resolution; and declaring the necessity that this Resolution become immediately effective. [See Page 48]

Sponsor: County Executive Budish/Department of Law and Department of Public Works/Sanitary Sewer Division

**b) CONSIDERATION OF RESOLUTIONS FOR FIRST READING AND REFERRAL TO COMMITTEE**

- 1) R2021-0250: A Resolution confirming the County Executive's reappointment of various individuals to serve on the Cuyahoga County Board of Developmental Disabilities for the term 1/27/2022 – 1/22/2026; and declaring the necessity that this Resolution become immediately effective: [See Page 51]
  - i) Lisa M. Hunt
  - ii) Mozelle Jackson

Sponsor: County Executive Budish

- 2) R2021-0251: A Resolution confirming the County Executive's appointment of Karolyn Isenhardt to serve on the Cuyahoga Arts and Culture Board of Trustees for an unexpired term

ending 3/31/2024; and declaring the necessity that this Resolution become immediately effective. [See Page 64]

Sponsor: County Executive Budish

- 3) R2021-0252: A Resolution authorizing an amendment to revenue generating Agreement No. 50 with City of Cleveland to lease space in the City of Cleveland Police Department Headquarters, located at 1300 Ontario Street, Cleveland, for the period 10/2/2018 – 10/1/2021 to exercise an option to extend the time period to 10/1/2022 and for a lease amount of \$16.00 per square foot per annum, plus parking fees and the cost of the City of Cleveland’s proportional share of utilities; authorizing the County Executive to execute the amendment and all other documents consistent with this Resolution; and declaring the necessity that this Resolution become immediately effective. [See Page 70]

Sponsor: County Executive Budish/Department of Public Works

- 4) R2021-0253: A Resolution authorizing an amendment to revenue generating Agreement No. 1864 with The Huntington National Bank, the successor in interest of FirstMerit Corporation, for the sale of naming rights for the Cleveland Convention Center for the period 11/1/2015 - 10/31/2035, to extend the time period to 10/31/2036; authorizing the County Executive to execute the amendment and all other documents consistent with this Resolution; and declaring the necessity that this Resolution become immediately effective. [See Page 78]

Sponsor: County Executive Budish/Department of Public Works

- 5) R2021-0254: A Resolution approving Right-of-Way Exhibits as set forth in Plat No. M-5051 for reconstruction of Stearns Road from Schady Road to Bagley Road in Olmsted Township; authorizing the County Executive through the Department of Public Works to acquire said necessary Rights-of-Way; and declaring the necessity that this Resolution become immediately effective. [See Page 86]

Sponsor: County Executive Budish/Department of Public Works/Division of County Engineer

- 6) R2021-0255: A Resolution authorizing a Contract with Clark, Schaefer, Hackett & Co., in the amount not-to-exceed \$2,320,000.00 for annual audits for Calendar Years 2021-2025 for the period 9/30/2021 – 12/31/2026; authorizing the County Executive to execute Contract No. 1725 and all other documents consistent with this Resolution; and declaring the necessity that this Resolution become immediately effective. [See Page 129]

Sponsor: County Executive Budish/Fiscal Department

- 7) R2021-0256: A Resolution designating agreements with various eligible institutions, as public depositories of active and interim funds of Cuyahoga County in the total deposit limit amount not-to-exceed \$1,215,000,000.00 for the period 8/1/2021 – 4/1/2024, in accordance with the Uniform Depository Act of Ohio; authorizing the County Executive and/or Treasurer to execute the agreements and all other documents consistent with said award and this Resolution; and declaring the necessity that this Resolution become immediately effective: [See Page 137]
- a) Dollar Bank, Federal Savings Bank in the deposit limit amount not-to-exceed \$50,000,000.00.
  - b) First Federal Savings and Loan Association of Lakewood in the deposit limit amount not-to-exceed \$5,000,000.00.
  - c) The Huntington National Bank in the deposit limit amount not-to-exceed \$200,000,000.00.
  - d) JP Morgan Chase Bank, N.A. in the deposit limit amount not-to-exceed \$200,000,000.00.
  - e) KeyBank National Association in the deposit limit amount not-to-exceed \$700,000,000.00.
  - f) PNC Bank in the deposit limit amount not-to-exceed \$10,000,000.00.
  - g) U.S. Bank National Association in the deposit limit amount not-to-exceed \$50,000,000.00.

Sponsor: County Executive Budish/County Treasurer



- 8) R2021-0257: A Resolution authorizing an amendment to Contract No. 256 with Lutheran Metropolitan Ministry for adult guardianship services for the period 1/1/2021 – 12/31/2021 to extend the time period to 12/31/2022 and for additional funds in the amount not-to-exceed \$605,285.00; authorizing the County Executive to execute the amendment and all other documents consistent with this Resolution; and declaring the necessity that this Resolution become immediately effective. [See Page 142]

Sponsor: County Executive Budish/Department of Health and Human Services/Division of Senior and Adult Services

**c) COMMITTEE REPORT AND CONSIDERATION OF A RESOLUTION FOR SECOND READING**

- 1) R2021-0246: A Resolution authorizing Contract No. 1904 with Fund for Our Economic Future of Northeast Ohio, as fiscal agent, in the amount not-to-exceed \$1,450,000.00 to support workforce innovation and coordination in healthcare, manufacturing, information technology and hospitality sectors in connection with the Workforce Connect Development Program for the period 1/1/2022 – 12/31/2024; authorizing the County Executive to execute the contract and all other documents consistent with this Resolution and declaring the necessity that this Resolution become immediately effective. [See Page 150]

Sponsor: County Executive Budish/Department of Development

Committee Assignment and Chair: Committee of the Whole – Jones

**d) COMMITTEE REPORTS AND CONSIDERATION OF RESOLUTIONS FOR THIRD READING ADOPTION**

- 1) R2021-0218: A Resolution amending the 2020/2021 Biennial Operating Budget for 2021 by providing for additional fiscal appropriations from the General Fund and other funding sources, for appropriation transfers between budget accounts and for cash transfers between budgetary funds, to meet the budgetary needs of various County departments, offices and agencies; and declaring the necessity that this Resolution become immediately effective. [See Page 162]

Sponsor: County Executive Budish/Fiscal Officer/Office of Budget and Management

Committee Assignment and Chair: Committee of the Whole – Jones

- 2) R2021-0219: A Resolution authorizing the issuance and sale of one or more series of County sales tax revenue bonds, in an aggregate principal amount not to exceed \$202,500,000, for the purpose of paying or reimbursing the costs of reconstructing, refurbishing, renovating, upgrading, improving and equipping Progressive Field, together with appurtenances and work incidental thereto, and for the purpose of paying any capitalized interest on the bonds, making any required reserve deposits and paying the costs of issuance in connection therewith; authorizing the preparation and use of one or more preliminary official statements and the preparation, execution and use of one or more official statements; approving and authorizing the execution of one or more trust indentures or supplemental trust indentures and one or more continuing disclosure agreements; authorizing other contracts and other actions related to and necessary for the issuance of the bonds; and declaring the necessity that this Resolution become immediately effective. [See Page 166]

Sponsor: County Executive Budish/Fiscal Officer/Office of Budget and Management

Committee Assignment and Chair: Committee of the Whole – Jones

**e) COMMITTEE REPORT AND CONSIDERATION OF AN ORDINANCE FOR THIRD READING ADOPTION**

- 1) O2021-0013: An Ordinance amending Chapter 503 of the Cuyahoga County Code: Small Business Enterprise Program Policies and Procedures to approve revised Cuyahoga County Small Business Enterprise Program Policies and Procedures, effective 11/15/2021 and adopt Minority Business Enterprise (MBE) & Women Business Enterprise (WBE) Program Policies and Procedures, effective 11/15/2021; and declaring the necessity that this Ordinance become immediately effective. [See Page 192]

Sponsor: County Executive Budish/Department of Equity and Inclusion

Committee Assignment and Chair: Public Works, Procurement & Contracting – Tuma

**10. MISCELLANEOUS COMMITTEE REPORTS**

**11. MISCELLANEOUS BUSINESS**

**12. ADJOURNMENT**

NEXT MEETING

REGULAR MEETING:

TUESDAY, November 23, 2021  
5:00 PM / COUNCIL CHAMBERS

*\*Complimentary parking for the public is available in the attached garage at 900 Prospect. A skywalk extends from the garage to provide additional entry to the Council Chambers from the 5<sup>th</sup> floor parking level of the garage. Please see the Clerk to obtain a complimentary parking pass.*

*\*\*Council Chambers is equipped with a hearing assistance system. If needed, please see the Clerk to obtain a receiver.*



## MINUTES

CUYAHOGA COUNTY COMMITTEE OF THE WHOLE MEETING  
MONDAY, OCTOBER 25, 2021  
CUYAHOGA COUNTY ADMINISTRATIVE HEADQUARTERS  
C. ELLEN CONNALLY COUNCIL CHAMBERS – 4<sup>TH</sup> FLOOR  
1:00 PM

### 1. CALL TO ORDER

**Councilmember Miller, Chair of the Finance & Budgeting Committee, called the meeting to order at 1:05 p.m.**

### 2. ROLL CALL

**Mr. Miller asked Clerk Richardson to call the roll. Councilmembers Baker, Miller, Sweeney, Tuma, Gallagher and Jones were in attendance and a quorum was determined. Councilmembers Conwell, Schron, Brown, Simon and Stephens were in attendance after the roll-call was taken.**

### 3. PUBLIC COMMENT

**There were no public comments given.**

### 4. MATTER REFERRED TO COMMITTEE / DISCUSSION:

- a) R2021-0238: A Resolution adopting the 2022/2023 Biennial Operating Budget and Capital Improvements Program; and declaring the necessity that this Resolution become immediately effective:

- 1) General Government and Supportive Services:

- a. Department of Information Technology (including ERP) – Andy Johnson

**Mr. Andy Johnson, Chief Information Officer, addressed Council regarding budget requests for the Department of Information Technology. Discussion ensued.**

**Councilmembers asked questions of Mr. Johnson pertaining to the item, which he answered accordingly.**

b. Office of the Fiscal Officer – Michael W. Chambers

**Mr. Michael Chambers, Fiscal Officer, addressed Council regarding budget requests for the Fiscal Office. Discussion ensued.**

**Councilmembers asked questions of Mr. Chambers pertaining to the item, which he answered accordingly.**

c. Office of Innovation and Performance – Rebecca Eby

**Ms. Rebecca Eby, Interim Chief Innovation and Performance Officer, addressed Council regarding budget requests for the Office of Innovation and Performance. Discussion ensued.**

**Councilmembers asked questions of Ms. Eby pertaining to the item, which she answered accordingly.**

d. Department of Purchasing – Catherine Tkachyk

**Ms. Catherine Tkachyk, Interim Director of the Department of Purchasing, addressed Council regarding budget requests for the Department of Purchasing. Discussion ensued.**

**Councilmembers asked questions of Ms. Tkachyk pertaining to the item, which she answered accordingly.**

e. Department of Equity and Inclusion – Lenora M. Lockett

**Ms. Lenora Lockett, Director of the Department of Equity and Inclusion, addressed Council regarding budget requests for the Department of Equity and Inclusion. Discussion ensued.**

**Councilmembers asked questions of Ms. Lockett pertaining to the item, which she answered accordingly.**

**At 2:50 p.m., a brief recess was taken by Council, after which Mr. Miller then reconvened the meeting.**

f. Department of Human Resources/Healthcare Benefits – Jesse Drucker

**Mr. Jesse Drucker, Director of Human Resources, addressed Council regarding budget requests for the Department of Human Resources. Discussion ensued.**

**Councilmembers asked questions of Mr. Drucker pertaining to the item, which he answered accordingly.**

- g. Cuyahoga County Personnel Review Commission – Rebecca Kopcienski

**Mr. Miller announced that the Cuyahoga County Personnel Review Commission budget presentation will be rescheduled for Monday, November 1, 2021.**

- h. Department of Communications – Mary Louise Madigan

**Ms. Mary Louise Madigan, Interim Director of the Department of Communications, addressed Council regarding budget requests for the Department of Communications. Discussion ensued.**

**Councilmembers asked questions of Ms. Madigan pertaining to the item, which she answered accordingly.**

- i. Cuyahoga County Board of Elections – Anthony Perlatti

**Mr. Anthony Perlatti, Director of the Cuyahoga County Board of Elections, addressed Council regarding budget requests for the Cuyahoga County Board of Elections. Discussion ensued.**

**Councilmembers asked questions of Mr. Perlatti pertaining to the item, which he answered accordingly.**

- j. Department of Internal Audit – Monica Houston

**Ms. Monica Houston, Director of Internal Audit, addressed Council regarding budget requests for the Department of Internal Audit. Discussion ensued.**

**Councilmembers asked questions of Ms. Houston pertaining to the item, which she answered accordingly.**

- k. Agency of the Inspector General – Mark Griffin

**Mr. Mark Griffin, Inspector General, addressed Council regarding budget requests for the Agency of the Inspector General. Discussion ensued.**

**Councilmembers asked questions of Mr. Griffin pertaining to the item, which he answered accordingly.**

- l. Department of Law – Gregory Huth

**Mr. Gregory Huth, Law Director, addressed Council regarding budget requests for the Department of Law. Discussion ensued.**

**Councilmembers asked questions of Mr. Huth pertaining to the item, which he answered accordingly.**

m. Sheriff's Department – Sheriff Christopher Viland

**Mr. Christopher Viland, Sheriff, addressed Council regarding budget requests for the Sheriff's Department. Discussion ensued.**

**Councilmembers asked questions of Sheriff Viland pertaining to the item, which he answered accordingly.**

n. Office of the County Treasurer – W. Christopher Murray

**Mr. W. Christopher Murray, County Treasurer, addressed Council regarding budget requests for the Office of the County Treasurer. Discussion ensued.**

**Councilmembers asked questions of Mr. Murray pertaining to the item, which he answered accordingly.**

5. MISCELLANEOUS BUSINESS

**Mr. Miller announced that the next budget presentations will take place in the Committee of the Whole on Monday, November 1, 2021 at 1:00 p.m.**

6. ADJOURNMENT

**With no further business to discuss, Mr. Miller adjourned the meeting at 5:28 p.m., without objection.**





## MINUTES

CUYAHOGA COUNTY COUNCIL COMMITTEE OF THE WHOLE MEETING  
TUESDAY, OCTOBER 26, 2021  
CUYAHOGA COUNTY ADMINISTRATIVE HEADQUARTERS  
C. ELLEN CONNALLY COUNCIL CHAMBERS – 4<sup>TH</sup> FLOOR  
4:00 PM

### 1. CALL TO ORDER

**Council President Jones called the meeting to order at 4:08 p.m.**

### 2. ROLL CALL

**Council President Jones asked Clerk Richardson to call the roll. Councilmembers Conwell, Simon, Baker, Miller, Sweeney, Tuma, Gallagher, Schron and Jones were in attendance and a quorum was determined. Councilmembers Brown and Stephens joined the meeting after the roll-call was taken to move to executive session.**

### 3. PUBLIC COMMENT

**There were no public comments given.**

### 4. EXECUTIVE SESSION

#### a) Collective bargaining matters, including:

- 1) approving a Collective Bargaining Agreement between Cuyahoga County and Communication Workers of America, Local 4340, Clerk of Courts Bargaining Unit, representing approximately 66 employees in the Clerk, Legal Account Clerk (1/2/3), and Legal Clerk 3 classifications in the Clerk of Courts for the period 1/1/2021 - 12/31/2023.

#### b) Pending or imminent litigation.

**A motion was made by Mr. Sweeney, seconded by Ms. Simon and approved by unanimous roll-call vote to move to Executive Session for the purpose of discussing a**

collective bargaining matter and pending or imminent litigation and for no other purpose whatsoever. Executive Session was then called to order by Council President Jones at 4:11 p.m. The following Councilmembers were present Conwell, Simon, Baker, Miller, Sweeney, Tuma, Gallagher, Schron and Jones.

[Clerk's Note: Councilmembers Brown and Stephens joined the meeting after the roll-call was taken to move to Executive Session.]

The following additional attendees were present: Director of Law Gregory Huth; Assistant Law Director Sarah Nemastil; Assistant Law Director Steve Ritz; Civil Division Chief David Lambert; Council Chief of Staff Joseph Nanni; Legislative Budget Advisor Trevor McAleer; Special Counsel Brendan Doyle and Research and Policy Advisor James Boyle.

At 5:03 p.m., Executive Session was adjourned without objection and Council President Jones then reconvened the meeting.

5. MISCELLANEOUS BUSINESS

There was no miscellaneous business.

6. ADJOURNMENT

With no further business to discuss, Council President Jones adjourned the meeting at 5:04 p.m., without objection.



MINUTES  
CUYAHOGA COUNTY COMMITTEE OF THE WHOLE MEETING  
MONDAY, NOVEMBER 1, 2021  
CUYAHOGA COUNTY ADMINISTRATIVE HEADQUARTERS  
C. ELLEN CONNALLY COUNCIL CHAMBERS – 4<sup>TH</sup> FLOOR  
1:00 PM

1. CALL TO ORDER

**Councilmember Miller, Chair of the Finance & Budgeting Committee, called the meeting to order at 1:03 p.m.**

2. ROLL CALL

**Mr. Miller asked Clerk Richardson to call the roll. Councilmembers Baker, Miller, Sweeney, Tuma, Gallagher, Schron and Conwell were in attendance and a quorum was determined. Councilmembers Jones, Simon and Stephens were in attendance after the roll-call was taken. Councilmember Brown was absent from the meeting.**

3. PUBLIC COMMENT

**Loh addressed Council regarding various agenda and non-agenda items.**

**[Clerk's Note: Item No. 4.b) was taken out of order and considered before Item No. 4.a).]**

4. MATTERS REFERRED TO COMMITTEE / DISCUSSION:

- a) R2021-0246: A Resolution authorizing Contract No. 1904 with Fund for Our Economic Future of Northeast Ohio, as fiscal agent, in the amount not-to-exceed \$1,450,000.00 to support workforce innovation and coordination in healthcare, manufacturing, information technology and hospitality sectors in connection with the Workforce Connect Development Program for the period 1/1/2022 – 12/31/2024; authorizing the County Executive to execute the contract and all other documents consistent with this Resolution; and declaring the necessity that this Resolution become immediately effective.

**Mr. Miller passed the gavel to Mr. Schron, Chair of the Economic Development & Planning Committee.**

**Mr. Paul Herdeg, Director of the Department of Development; and Ms. Cathy Belk, Chief Executive Officer of the Deaconess Foundation, addressed Council regarding Resolution No. R2021-0246. Discussion ensued.**

**Councilmembers asked questions of Mr. Herdeg and Ms. Cathy pertaining to the item, which they answered accordingly**

**On a motion by Mr. Miller with a second by Ms. Stephens, Resolution No. R2021-0246 was considered and approved by unanimous vote to be referred to the full Council agenda for second reading.**

**Mr. Schron returned the gavel to Mr. Miller to chair the remainder of the meeting.**

- b) R2021-0238: A Resolution adopting the 2022/2023 Biennial Operating Budget and Capital Improvements Program, and declaring the necessity that this Resolution become immediately effective:

- 1) Justice Services and Public Safety Brief Overview – Robert Coury

**Mr. Robert Coury, Chief Public Safety & Justice Services Officer, addressed Council regarding budget requests for the Department of Justice Services and Public Safety. Discussion ensued.**

**Councilmembers asked questions of Mr. Coury pertaining to the item, which he answered accordingly.**

- 2) Cuyahoga County Court of Common Pleas:

- a. General Division – The Honorable Brendan J. Sheehan

**The Honorable Brendan J. Sheehan, Administrative and Presiding Judge of the Court of Common Pleas, addressed Council regarding budget requests for the General Division of the Court of Common Pleas. Discussion ensued.**

**Councilmembers asked questions of Judge Sheehan pertaining to the item, which he answered accordingly.**

- b. Juvenile Division – The Honorable Thomas F. O’Malley

**The Honorable Thomas F. O’ Malley, Administrative Judge of the Court of Common Pleas Juvenile Division; Mr. Timonthy Lubbe, Director of Fiscal Resources for the Juvenile Division; and Mr. Brandon Winarchick, Superintendent of Detention Services for the Juvenile Division, addressed Council regarding budget requests for the Court of Common Pleas Juvenile Division. Discussion ensued.**

**Councilmembers asked questions of Judge O’ Malley, Mr. Lubbe and Mr. Winarchick pertaining to the item, which they answered accordingly.**

- c. Domestic Relations Division – The Honorable Leslie Ann Celebrezze

**The Honorable Leslie Ann Celebrezze, Administrative Judge of Cuyahoga County Domestic Relations Court, addressed Council regarding budget requests for Cuyahoga County Domestic Relations Court. Discussion ensued.**

**Councilmembers asked questions of Judge Celebrezze pertaining to the item, which she answered accordingly.**

- d. Probate Division – The Honorable Anthony J. Russo

**The Honorable Anthony J. Russo, Administrative Judge of the Probate Division, addressed Council regarding budget requests for the Probate Division of the Court of Common Pleas. Discussion ensued.**

**Councilmembers asked questions of Judge Russo pertaining to the item, which he answered accordingly.**

- 3) Court of Appeals of Ohio, Eighth Appellate District – The Honorable Mary J. Boyle

**The Honorable Mary J. Boyle, Administrative Judge of Court of Appeals of Ohio, Eighth Appellate District, addressed Council regarding budget requests for the Court of Appeals. Discussion ensued.**

**Councilmembers asked questions of Judge Boyle pertaining to the item, which she answered accordingly.**

- 4) Office of the Prosecuting Attorney – The Honorable Michael C. O’Malley

**The Honorable Michael C. O’ Malley, Cuyahoga County Prosecutor; and Mr. James Ginley, Director of Finance and Operations for the Office of the Prosecuting Attorney, addressed Council regarding budget requests for the Office of the Prosecuting Attorney. Discussion ensued.**

**Councilmembers asked questions of Prosecutor O’ Malley and Mr. Ginley pertaining to the item, which they answered accordingly.**

**At 2:59 p.m., a brief recess was taken by Council after which, Mr. Miller then reconvened the meeting.**

- 5) Public Defender Commission – Cullen Sweeney

**The Honorable Mr. Cullen Sweeney, Chief Public Defender, addressed Council regarding budget requests for the Public Defender Commission. Discussion ensued.**

**Councilmembers asked questions of Mr. Sweeney pertaining to the item, which he answered accordingly.**

- 6) Cuyahoga County Personnel Review Commission – Rebecca Kopcienski

**Ms. Rebecca Kopcienski, Director of the Personnel Review Commission, addressed Council regarding budget requests for the Personnel Review Commission. Discussion ensued.**

**Councilmembers asked questions of Ms. Kopcienski pertaining to the item, which she answered accordingly.**

5. MISCELLANEOUS BUSINESS

**Mr. Miller announced that the next Committee of the Whole meeting will be held on Thursday, November 4, 2021 at 1:00 p.m.**

6. ADJOURNMENT

**With no further business to discuss, Mr. Miller adjourned the meeting at 3:48 p.m., without objection.**



## **MINUTES**

**CUYAHOGA COUNTY COUNCIL REGULAR MEETING  
TUESDAY, OCTOBER 26, 2021  
CUYAHOGA COUNTY ADMINISTRATIVE HEADQUARTERS  
C. ELLEN CONNALLY COUNCIL CHAMBERS – 4<sup>TH</sup> FLOOR  
5:00 PM**

**1. CALL TO ORDER**

**Council President Jones called the meeting to order at 5:09 p.m.**

**2. ROLL CALL**

**Council President Jones asked Clerk Richardson to call the roll. Councilmembers Simon, Baker, Miller, Tuma, Gallagher, Schron, Conwell, Brown, Stephens and Jones were in attendance and a quorum was determined. Councilmember Sweeney was in attendance after the roll-call was taken.**

**3. PLEDGE OF ALLEGIANCE**

**The Pledge of Allegiance was recited.**

**4. SILENT MEDITATION**

**Council President Jones requested a moment of silent meditation for personal reflection.**

**5. PUBLIC COMMENT**

**Loh addressed Council regarding various agenda and non-agenda items.**

**The following individuals addressed Council regarding Resolution No. R2021-0218 amending the 2020/2021 Biennial Operating Budget for 2021 by providing for additional fiscal appropriations from the General Fund and other funding sources,**

**for appropriation transfers between budget accounts and for cash transfers between budgetary funds, to meet the budgetary needs of various County departments, offices and agencies and Resolution No. R2021-0219 authorizing the issuance and sale of one or more series of County sales tax revenue bonds, in an aggregate principal amount not to exceed \$202,500,000, for the purpose of paying or reimbursing the costs of reconstructing, refurbishing, renovating, upgrading, improving and equipping Progressive Field:**

- a) The Honorable Mayor Matt Burke, Mayor of Garfield Heights, Ohio**
- b) Mr. Nick Kostas**
- c) Mr. Keith Siebenaler**
- d) Mr. William Tarter, Jr.**
- e) Mr. Andi Udris**
- f) Mr. Dave Wondolowski**

**A representative from the following organization did not address Council, but submitted written testimony via email for the record:**

- a) Ms. Karen Paganini, President, K & D Group**

**6. APPROVAL OF MINUTES**

- a) October 7, 2021 Committee of the Whole Meeting**
- b) October 12, 2021 Committee of the Whole Meeting**
- c) October 14, 2021 Committee of the Whole Meeting**
- d) October 18, 2021 Committee of the Whole Meeting**
- e) October 19, 2021 Committee of the Whole Meeting**
- f) October 21, 2021 Committee of the Whole Meeting**
- g) October 12, 2021 Regular Meeting**

**A motion was made by Ms. Brown, seconded by Mr. Schron and approved by unanimous vote to approve the minutes from the October 7, 2021; October 12, 2021; October 14, 2021; October 18, 2021; October 19, 2021; and October 21, 2021 Committee of the Whole meetings and the October 12, 2021 Regular meeting.**

**7. ANNOUNCEMENTS FROM THE COUNCIL PRESIDENT**

**There were no announcements from Council President Jones.**

**8. MESSAGES FROM THE COUNTY EXECUTIVE**

**County Executive Budish reported on the status of a new innovation hub partnered by Nottingham Spirk and EY, which will result in the leveraging of national and international markets. Executive Budish also provided an update on the**



**groundbreaking of the new Sherwin Williams research and development facility in Brecksville, Ohio.**

9. LEGISLATION INTRODUCED BY COUNCIL

a) CONSIDERATION OF A RESOLUTION OF COUNCIL FOR FIRST READING AND REFERRAL TO COMMITTEE

- 1) R2021-0239: A Resolution adopting various changes to the Cuyahoga County Non-bargaining Classification Plan; and declaring the necessity that this Resolution become immediately effective.

Sponsor: Councilmember Brown on behalf of Cuyahoga County Personnel Review Commission

**Council President Jones referred Resolution No. R2021-0239 to the Human Resources, Appointments & Equity Committee.**

10. LEGISLATION INTRODUCED BY EXECUTIVE

b) CONSIDERATION OF RESOLUTIONS FOR FIRST READING ADOPTION UNDER SUSPENSION OF RULES

**A motion was made by Mr. Gallagher, seconded by Ms. Brown and approved by unanimous vote to suspend Rules 9D and 12A and to place on final passage Resolution No. R2021-0240 and R2021-0241.**

- 1) R2021-0240: A Resolution amending the 2020/2021 Biennial Operating Budget for 2021 by providing for additional fiscal appropriations from the General Fund and other funding sources, for appropriation transfers between budget accounts and for cash transfers between budgetary funds, to meet the budgetary needs of various County departments, offices and agencies, amending Resolution No. R2021-0192 dated 8/23/2021; and declaring the necessity that this Resolution become immediately effective.

Sponsor: County Executive Budish/Fiscal Officer/Office of Budget and Management

**On a motion by Mr. Miller with a second by Mr. Sweeney, Resolution No. R2021-0240 was considered and adopted by unanimous vote.**

- 2) R2021-0241: A Resolution approving a Collective Bargaining Agreement between Cuyahoga County and Communication Workers of America, Local 4340, Clerk of Courts Bargaining Unit, representing approximately 66 employees in the Clerk, Legal Account Clerk (1/2/3), and Legal Clerk 3 classifications in the Clerk of Courts for the period 1/1/2021 - 12/31/2023; directing that funds necessary to implement the Collective Bargaining Agreement be budgeted and appropriated; authorizing the County Executive to execute the agreement and all other documents consistent with this Resolution; and declaring the necessity that this Resolution become immediately effective.

Sponsor: County Executive Budish/Department of Law/Clerk of Courts

**On a motion by Mr. Jones with a second by Mr. Schron, Resolution No. R2021-0241 was considered and adopted by unanimous vote.**

c) CONSIDERATION OF RESOLUTIONS FOR FIRST READING AND REFERRAL TO COMMITTEE

- 1) R2021-0242: A Resolution confirming the County Executive's appointment of the Honorable Mayor Annette Blackwell to serve on the Cuyahoga County Citizens' Advisory Council on Equity for an unexpired term ending 7/14/2022; and declaring the necessity that this Resolution become immediately effective.

Sponsor: County Executive Budish

**Council President Jones referred Resolution No. R2021-0242 to the Human Resources, Appointments & Equity Committee.**

- 2) R2021-0243: A Resolution declaring that public convenience and welfare requires the replacement of West 130<sup>th</sup> Street Bridge No. 02.26 over the East Branch of the Rocky River in the Cities of North Royalton and Strongsville; total estimated project cost \$3,750,000.00; finding that special assessments will neither be levied nor collected to pay for any part of the County's costs of said improvement; and declaring the necessity that this Resolution become immediately effective.

Sponsor: County Executive Budish/Department of Public Works

**Council President Jones referred Resolution No. R2021-0243 to the Public Works, Procurement & Contracting Committee.**

- 3) R2021-0244: A Resolution authorizing an amendment to Contract No. 610 with C&S Engineers, Inc. for general engineering services for the Cuyahoga County Airport for the period 2/10/2020 – 2/13/2025 for additional funds in the amount not-to-exceed \$1,500,000.00; authorizing the County Executive to execute the amendment and all other documents consistent with this Resolution; and declaring the necessity that this Resolution become immediately effective.

Sponsor: County Executive Budish/Department of Public Works

**Council President Jones referred Resolution No. R2021-0244 to the Public Works, Procurement & Contracting Committee.**

- 4) R2021-0245: A Resolution authorizing an award on RQ6464 to M-B Companies in the amount not-to-exceed \$545,550.00 for the purchase of snow removal equipment for the County Airport; authorizing the County Executive to execute Purchase Order No. 21003532 and all other documents consistent this award; and declaring the necessity that this Resolution become immediately effective.

Sponsor: County Executive Budish/Department of Public Works/Division of County Engineer

**Council President Jones referred Resolution No. R2021-0245 to the Public Works, Procurement & Contracting Committee.**

- 5) R2021-0246: A Resolution authorizing Contract No. 1904 with Fund for Our Economic Future of Northeast Ohio, as fiscal agent, in the amount not-to-exceed \$1,450,000.00 to support workforce innovation and coordination in healthcare, manufacturing, information technology and hospitality sectors in connection with the Workforce Connect Development Program for the period 1/1/2022 – 12/31/2024; authorizing the County Executive to execute the contract and all other documents consistent with this Resolution; and declaring the necessity that this Resolution become immediately effective.

Sponsor: County Executive Budish/Department of Development

**Council President Jones referred Resolution No. R2021-0246 to the Committee of the Whole.**

- 6) R2021-0247: A Resolution authorizing an amendment to Contract No. 1631 with Applewood Centers, Inc. for Multisystemic Therapy/Multisystemic Therapy-Problem Sexual Behavior Services for adjudicated youth for the period 7/1/2016 – 6/30/2021 to extend the time period to 6/30/2022, and for additional funds in the amount not-to-exceed \$600,000.00; authorizing the County Executive to execute the amendment and all other documents consistent with this Resolution; and declaring the necessity that this Resolution become immediately effective.

Sponsor: County Executive Budish/on behalf of Cuyahoga County Court of Common Pleas/Juvenile Court Division

**Council President Jones referred Resolution No. R2021-0247 to the Public Safety & Justice Affairs Committee.**

- d) COMMITTEE REPORTS AND CONSIDERATION OF RESOLUTIONS FOR SECOND READING

- 1) R2021-0218: A Resolution amending the 2020/2021 Biennial Operating Budget for 2021 by providing for additional fiscal appropriations from the General Fund and other funding sources, for appropriation transfers between budget accounts and for cash transfers between budgetary funds, to meet the budgetary needs of various County departments, offices and agencies; and declaring the necessity that this Resolution become immediately effective.

Sponsor: County Executive Budish/Fiscal Officer/Office of Budget and Management

Committee Assignment and Chair: Committee of the Whole – Jones

**Clerk Richardson read Resolution No. R2021-0218 into the record.**

**This item will move to the November 9, 2021 Council meeting agenda for consideration for third reading adoption.**

- 2) R2021-0219: A Resolution authorizing the issuance and sale of one or more series of County sales tax revenue bonds, in an aggregate principal amount not to exceed \$202,500,000, for the purpose of paying or reimbursing the costs of

reconstructing, refurbishing, renovating, upgrading, improving and equipping Progressive Field, together with appurtenances and work incidental thereto, and for the purpose of paying any capitalized interest on the bonds, making any required reserve deposits and paying the costs of issuance in connection therewith; authorizing the preparation and use of one or more preliminary official statements and the preparation, execution and use of one or more official statements; approving and authorizing the execution of one or more trust indentures or supplemental trust indentures and one or more continuing disclosure agreements; authorizing other contracts and other actions related to and necessary for the issuance of the bonds; and declaring the necessity that this Resolution become immediately effective.

Sponsor: County Executive Budish/Fiscal Officer/Office of Budget and Management

Committee Assignment and Chair: Committee of the Whole – Jones

**Clerk Richardson read Resolution No. R2021-0219 into the record.**

**This item will move to the November 9, 2021 Council meeting agenda for consideration for third reading adoption.**

- e) COMMITTEE REPORTS AND CONSIDERATION OF RESOLUTIONS FOR SECOND READING ADOPTION UNDER SUSPENSION OF RULES

**A motion was made by Mr. Gallagher, seconded by Ms. Brown and approved by unanimous vote to suspend Rule 9D and to place on final passage Resolution Nos. R2021-0231, R2021-0232, R2021-0233, R2021-0234, R2021-0235, R2021-0236 and R2021-0237.**

- 1) R2021-0231: A Resolution confirming the County Executive's appointment of Cheryl Bradas to serve on the Cuyahoga County Advisory Board on Senior and Adult Services for an unexpired term ending 12/31/2021; and declaring the necessity that this Resolution become immediately effective.

Sponsor: County Executive Budish  
Committee Assignment and Chair: Human Resources, Appointments & Equity – Brown

**On a motion by Ms. Brown with a second by Ms. Conwell, Resolution No. R2021-0231 was considered and adopted by unanimous vote.**

- 2) R2021-0232: A Resolution confirming the County Executive's reappointment of Sam Thomas III to serve on the Western Reserve Area Agency on Aging Board of Trustees for the term 1/1/2021 – 12/31/2023; and declaring the necessity that this Resolution become immediately effective.

Sponsor: County Executive Budish

Committee Assignment and Chair: Human Resources,  
Appointments & Equity – Brown

**On a motion by Ms. Brown with a second by Ms. Conwell, Resolution No. R2021-0232 was considered and adopted by unanimous vote.**

- 3) R2021-0233: A Resolution authorizing the appropriation of real property for replacement of Old Rockside Road Bridge No. 00.42 over the Cuyahoga River in the City of Independence and Village of Valley View; authorizing the County Executive, through the Department of Public Works, to proceed with the acquisition of real property required for public highway purposes; authorizing the Fiscal Officer to issue the monetary warrants to be deposited with the Probate Court of Cuyahoga County in an amount that is equal to the fair market value of the property; and declaring the necessity that this Resolution become immediately effective.

Sponsor: County Executive Budish/Department of Public Works/Division of County Engineer

Committee Assignment and Chair: Public Works, Procurement & Contracting – Tuma

**On a motion by Mr. Tuma with a second by Ms. Brown, Resolution No. R2021-0233 was considered and adopted by unanimous vote.**

- 4) R2021-0234: A Resolution authorizing an amendment to Agreement No. 968 with State of Ohio/Department of Administrative Services/Office of Information Technology for software licenses and maintenance on an IBM LPAR Mainframe for the period 3/1/2018 - 12/31/2020 to extend the time period to 8/31/2022 and for additional funds in the amount not-to-exceed \$700,000.00; authorizing the County

Executive to execute the amendment and all other documents consistent with this Resolution; and declaring the necessity that this Resolution become immediately effective.

Sponsor: County Executive Budish/Department of Information Technology

Committee Assignment and Chair Committee of the Whole – Jones

**On a motion by Mr. Miller with a second by Mr. Sweeney, Resolution No. R2021-0234 was considered and adopted by unanimous vote.**

- 5) R2021-0235: A Resolution making awards on RQ4810 to various providers in the total amount not-to-exceed \$1,720,659.34 for trauma informed respite and youth care center services for the period 9/1/2021 – 6/30/2023; authorizing the County Executive to execute the Master Contract and all other documents consistent with said awards and this Resolution; and declaring the necessity that this Resolution become immediately effective:
  - a) Contract No. 1813 with Raven House in the amount not-to-exceed \$654,641.67
  - b) Contract No. 1814 with Life’s Right Direction, Inc. in the amount not-to-exceed \$735,829.11
  - c) Contract No. 1815 with Lutheran Metropolitan Ministry in the amount not-to-exceed \$330,188.56

Sponsor: County Executive Budish/on behalf of Cuyahoga County Court of Common Pleas/Juvenile Court Division

Committee Assignment and Chair: Public Safety & Justice Affairs – Gallagher

**On a motion by Mr. Gallagher with a second by Mr. Miller, Resolution No. R2021-0235 was considered and adopted by unanimous vote.**

- 6) R2021-0236: A Resolution making an award on RQ6987 to Schwarz Uniform Corporation in the amount not-to-exceed \$875,000.00 for furnishing uniforms for Cuyahoga County Correction Officers for the period 1/1/2022 – 12/31/2024; authorizing the County Executive to execute Contract No.

1828 and all other documents consistent with said award and this Resolution; and declaring the necessity that this Resolution become immediately effective.

Sponsor: County Executive Budish/Sheriff's Department

Committee Assignment and Chair: Public Safety & Justice Affairs – Gallagher

**On a motion by Mr. Gallagher with a second by Mr. Sweeney, Resolution No. R2021-0236 was considered and adopted by unanimous vote.**

- 7) R2021-0237: A Resolution authorizing an amendment to a Master Contract with various municipalities and providers for various services for the Community Social Services Program for the period 1/1/2019 - 12/31/2021 to remove Eldercare Services Institute, LLC, effective 11/9/2021 and for additional funds in the total amount not-to-exceed \$600,000.00; authorizing the County Executive to execute the amendment and all other documents consistent with this Resolution; and declaring the necessity that this Resolution become immediately effective:
- a) Agreement No. 13 with City of Bedford Heights for Transportation services in the amount not-to-exceed \$12,000.00.
  - b) Agreement No. 127 with City of Olmsted Falls for Adult Development services in the amount not-to-exceed \$10,000.00.
  - c) Agreement No. 1142 formerly No. 23 with City of Strongsville for Adult Development and Transportation services in the amount not-to-exceed \$7,000.00.
  - d) Contract No. 130 with Community Partnership on Aging for Adult Development and Transportation services; no additional funds required.
  - e) Agreement No. 116 with City of Euclid for Adult Development, Home Delivered Meals and Transportation services in the amount not-to-exceed \$5,000.00.



- f) Agreement No. 115 with City of Lakewood for Adult Development, Home Delivered Meals and Transportation services in the amount not-to-exceed \$24,748.11.
- g) Agreement No. 145 with City of Maple Heights for Home Delivered Meals and Transportation services in the amount not-to-exceed \$25,000.00.
- h) Agreement No. 125 with City of Parma Heights for Adult Development, Home Delivered Meals and Transportation services in the amount not-to-exceed \$29,000.00.
- i) Contract No. 126 with Eliza Bryant Village for Adult Day, Home Delivered Meals and Transportation services in the amount not-to-exceed \$5,000.00.
- j) Contract No. 993 formerly No. 32 with The Phillis Wheatley Association of Cleveland, Ohio for Home Delivered Meals in the amount not-to-exceed \$38,000.00.
- k) Agreement No. 34 with City of Berea for Adult Development, Home Delivered Meals and Transportation services in the amount not-to-exceed \$43,000.00.
- l) Agreement No. 36 with City of Solon for Adult Development, Home Delivered Meals and Transportation services in the amount not-to-exceed \$23,000.00.
- m) Contract No. 31 with Catholic Charities Corporation on behalf of the Fatima Family Center for Adult Development and Home Delivered Meals in the amount not-to-exceed \$23,000.00.
- n) Contract No. 40 with Catholic Charities Corporation on behalf of the Hispanic Senior Center for Adult Development, Home Delivered Meals and Transportation services in the amount not-to-exceed \$12,000.00.

- o) Contract No. 79 with Catholic Charities Corporation on behalf of the St. Martin de Porres Family Center for Adult Development, Home Delivered Meals and Transportation services; no additional funds required.
- p) Contract No. 20 with Catholic Charities Corporation on behalf of the St. Philip-Neri Family Center for Adult Development and Home Delivered Meals; no additional funds required.
- q) Contract No. 995 formerly No. 46 with The East End Neighborhood House Association for Adult Development, Home Delivered Meals and Transportation services in the amount not-to-exceed \$42,000.00.
- r) Contract No. 55 with The Harvard Community Services Center for Adult Development, Home Delivered Meals and Transportation services in the amount not-to-exceed \$49,000.00.
- s) Contract No. 27 with The Mandel Jewish Community Center of Cleveland for Adult Development, Home Delivered Meals and Transportation services in the amount not-to-exceed \$16,000.00.
- t) Contract No. 57 with Murtis Taylor Human Services System for Adult Development, Home Delivered Meals and Transportation services in the amount not-to-exceed \$51,451.89.
- u) Contract No. 1284 formerly No. 65 with Rose Centers for Aging Well, LLC for Adult Development, Home Delivered Meals and Transportation services in the amount not-to-exceed \$52,000.00.
- v) Contract No. 138 with The Salvation Army for Adult Development, Home Delivered Meals and Transportation services; no additional funds required.
- w) Contract No. 56 with Senior Citizen Resources, Inc. for Adult Development, Home Delivered Meals and Transportation services in the amount not-to-exceed \$67,000.00.

- x) Contract No. 49 with University Settlement, Incorporated for Adult Development, Home Delivered Meals and Transportation services in the amount not-to-exceed \$55,800.00.
- y) Contract No. 58 with West Side Community House for Adult Development, Home Delivered Meals and Transportation services in the amount not-to-exceed \$10,000.00.

and to remove (1) provider, effective 11/9/2021

- z) Contract No. 30 with Eldercare Services Institute, LLC for Adult Day and Transportation services.

Sponsors: County Executive Budish/Department of Health and Human Services/Division of Senior and Adult Services and Councilmember Brown **and Councilmember Miller.**

Committee Assignment and Chair: Health, Human Services & Aging – Conwell

**On a motion by Ms. Conwell with a second by Mr. Miller, Resolution No. R2021-0237 was considered and adopted by unanimous vote.**

- f) COMMITTEE REPORTS AND CONSIDERATION OF RESOLUTIONS FOR THIRD READING ADOPTION
  - 1) R2021-0220: A Resolution authorizing the Director of Public Works to execute and submit a loan application in the amount of \$3,359,000.00 to State of Ohio, Ohio Public Works Commission to finance a portion of various Pleasant Valley Road Bridge Projects in various municipalities; authorizing the County Executive to accept said loan, if approved, and to execute the agreement and all other documents required in connection with said loan and this Resolution; and declaring the necessity that this Resolution become immediately effective:
    - a) Rehabilitation of Bridge No. 09.03 over Riverview Road and an unnamed creek in the City of Independence.
    - b) Rehabilitation of Bridge No. 09.35 over Cuyahoga Valley Scenic Railroad in the City of Independence.

- c) Replacement of Bridge No. 09.68 over Cuyahoga River in the City of Independence and Village of Valley View.

Sponsor: County Executive Budish/Department of Public Works/Division of Finance and Planning

Committee Assignment and Chair: Public Works, Procurement & Contracting – Tuma

**On a motion by Mr. Tuma with a second by Mr. Schron, Resolution No. R2021-0220 was considered and adopted by unanimous vote.**

- 2) R2021-0222: A Resolution authorizing an Economic Development Fund Redevelopment and Modernization Loan in the amount not-to-exceed \$1,000,000.00 to Manufacturing Advocacy and Growth Network for the redevelopment of a vacant building, located at 1800 East 63<sup>rd</sup> Street, City of Cleveland, for the relocation of MAGNET Manufacturing, Technology and Job Center Headquarters; authorizing the County Executive and/or Director of Development to execute all documents consistent with said loan and this Resolution; and declaring the necessity that this Resolution become immediately effective.

Sponsor: County Executive Budish/Department of Development **and Councilmembers Miller, Conwell, Stephens, Baker, Tuma, Simon, Sweeney, Brown and Jones**

Committee Assignment and Chair: Economic Development & Planning – Schron

**On a motion by Ms. Baker with a second by Ms. Simon, Resolution No. R2021-0222 was considered and adopted by majority vote, with Mr. Schron abstaining from the vote.**

- 3) R2021-0223: A Resolution authorizing an Economic Development Fund Redevelopment and Modernization Loan in the amount not-to-exceed \$1,000,000.00 to LG Blanket Mill, LLC for the redevelopment of a vacant building, located at 3160 West 33<sup>rd</sup> Street, City of Cleveland, for a mixed-use structure for the Northern Ohio Blanket Mills Project; authorizing the County Executive and/or Director of Development to execute all documents consistent with said loan and this Resolution; and declaring the necessity that this Resolution become immediately effective.

Sponsor: County Executive Budish/Department of Development **and Councilmembers Simon, Conwell, Stephens, Brown, Baker, Tuma and Jones**

Committee Assignment and Chair: Economic Development & Planning – Schron

**On a motion by Ms. Baker with a second by Mr. Miller, Resolution No. R2021-0223 was considered and adopted by unanimous vote.**

- 4) R2021-0225: A Resolution authorizing an amendment to Agreement No. 204 with The MetroHealth System for comprehensive medical services for families involved with Division of Children and Family Services for the period 1/1/2020 – 12/31/2021, to extend the time period to 12/31/2022 and for additional funds in the amount not-to-exceed \$1,551,000.00; authorizing the County Executive to execute the amendment and all other documents consistent with this Resolution; and declaring the necessity that this Resolution become immediately effective.

Sponsor: County Executive Budish/Department of Health and Human Services/Division of Children and Family Services

Committee Assignment and Chair: Health, Human Services & Aging – Conwell

**On a motion by Ms. Conwell with a second by Ms. Brown, Resolution No. R2021-0225 was considered and adopted by unanimous vote.**

- g) COMMITTEE REPORT AND CONSIDERATION OF AN ORDINANCE FOR SECOND READING

- 1) O2021-0013: An Ordinance amending Chapter 503 of the Cuyahoga County Code: Small Business Enterprise Program Policies and Procedures to approve revised Cuyahoga County Small Business Enterprise Program Policies and Procedures, effective 11/15/2021 and adopt Minority Business Enterprise (MBE) & Women Business Enterprise (WBE) Program Policies and Procedures, effective 11/15/2021; and declaring the necessity that this Ordinance become immediately effective.

Sponsor: County Executive Budish/Department of Equity and Inclusion

**Clerk Richardson read Ordinance No. O2021-0013 into the record.**

**This item will move to the November 9, 2021 Council meeting agenda for consideration for third reading adoption.**

**11. MISCELLANEOUS COMMITTEE REPORTS**

**Mr. Miller reported that the Committee of the Whole Budget meetings will be held on Monday, November 1<sup>st</sup> and Thursday, November 4<sup>th</sup> at 1:00 p.m.**

**Mr. Tuma reported that the Public Works Procurement & Contracting Committee will meet on Wednesday, November 3<sup>rd</sup> at 10:00 a.m.**

**Mr. Gallagher reported that the Human Resources, Appointments & Equity Committee will meet on Tuesday, November 2<sup>nd</sup> at 10:00 a.m.**

**Mr. Gallagher reported that the Public Safety & Justice Affairs Committee will meet on Tuesday, November 2<sup>nd</sup>, at 1:00 p.m.**

**Mr. Schron reported that he will be handling a Department of Development item during the Economic Development & Planning portion of the Committee of the Whole meeting on Monday, November 1<sup>st</sup> at 1:00 p.m.**

**12. MISCELLANEOUS BUSINESS**

**Council President Jones, Councilmembers Stephens, Baker, Miller, Sweeney, Tuma, Gallagher, Schron, Conwell, Simon and County Executive Budish offered remarks congratulating Councilmember Brown on her future endeavors in Congress as well as thanked her for her professionalism, courtesy, service and contributions to Cuyahoga County Council.**

**Councilmember Brown thanked all of the Councilmembers, County Executive Budish and the Administration, Council Staff and Constituents for the amazing work everyone has done collectively to make Cuyahoga County shine.**

**13. ADJOURNMENT**

**With no further business to discuss, Council President Jones adjourned the meeting at 6:25 p.m., without objection.**

# County Council of Cuyahoga County, Ohio

## Resolution No. R2021-0248

Sponsored by: <b>County Executive Budish/Fiscal Officer/Office of Budget and Management</b>	<b>A Resolution</b> amending the 2020/2021 Biennial Operating Budget for 2021 by providing for additional fiscal appropriations from the General Fund and other funding sources, for appropriation transfers between budget accounts and for cash transfers between budgetary funds, to meet the budgetary needs of various County departments, offices and agencies, amending Resolution No. R2021-0228 dated 10/12/2021; and declaring the necessity that this Resolution become immediately effective.
---	---

WHEREAS, on December 10, 2019, the Cuyahoga County Council adopted the Biennial Operating Budget and Capital Improvements Program for 2020/2021 (Resolution No. R2019-0224) establishing the 2020/2021 biennial budget for all County departments, offices and agencies; and

WHEREAS, it is necessary to adjust the Biennial Operating Budget for 2021 to reflect budgetary funding increases, funding reductions, to transfer budget appropriations and to transfer cash between budgetary funds, to accommodate the operational needs of certain County departments, offices and agencies; and

WHEREAS, it is further necessary that this Resolution become immediately effective in order that critical services provided by Cuyahoga County can continue and to provide for the usual, daily operation of County departments, offices, and agencies.

**NOW, THEREFORE, BE IT RESOLVED BY THE COUNTY COUNCIL OF CUYAHOGA COUNTY, OHIO:**

**SECTION 1.** That the 2020/2021 Biennial Operating Budget for 2021 be amended to provide for the following additional appropriation increases and decreases:

**Fund Nos./Budget Accounts**

**Journal Nos.**

A. General Fund **JE327**  
FS100110 – Financial Reporting  
Other Expenses \$ 190,000.00

The Fiscal Department Administration requests additional appropriation of \$190,000 to support a contract with G Force Technology Consulting, LLC. The consultant will collaborate efforts to review and correct issues with the current Lawson deployment, focusing on the cash and treasury management module. Funding source is the General Fund.

B. Other Community Development **JE411**  
EX275100 – Sustainability Projects  
Other Expenses \$ 10,000.00

The Department of Sustainability requests additional appropriation of \$10,000 for contract extension with Bongorno Consulting. Contractor will aid with the rebalancing location planning for the scooter program, which has been expanding into the suburbs. Funding source is the Sustainability Projects Fund which has current balance of \$558,000.

C. General Fund **JE418**  
EX100100 – County Executive  
Other Expenses \$ 12,351.00

The Office of Budget and Management on behalf of the County Executive requests additional appropriation of \$12,351 for the County Executives of America membership dues. The 2022 membership has been billed in advance and is payable immediately. Dues are based on county population, based on one cent per resident. Funding source is County General Fund.

D. Motor Vehicle Gas Tax **JE421**  
PW270205 – R & B Registration Tax  
Other Expenses \$ 6,173,788.61

Motor Vehicle Gas Tax  
PW270200 – Road Capital Improvements  
Other Expenses \$ 3,353,831.94

The Department of Public Works requests an appropriation increase in the \$7.50 Fund in the amount of \$6,173,788.61 as well as an appropriation increase in the \$5.00 Fund in the amount of \$3,353,831.94 to allow a cash transfer to Capital Projects a well as to the new \$5.00 Fund. Both the \$7.50 fund and \$5.00 fund is funded by the motor vehicle gas tax.

E. General Fund **JE425**  
FS100350 – General FD Operating Subsidies  
Other Expenses \$ 7,000,000.00



The Office of Budget and Management requests an appropriation increase in the amount of \$7,000,000 in the Fiscal Office General Fund Subsidy Account for a cash transfer to the Department of Development Economic Developments Fund. This cash transfer will cover \$7,000,000 of the payment from the Department of Developments Economic Development Fund to Sherwin Williams per Resolution R2020-0047 (See JE432 on this same agenda). Funding Source is General Fund Reserve.

F. General Fund		<b>JE426</b>
PR100100 – Personnel Review Commission		
Other Expenses	\$	93,730.00

The Office of Budget and Management recommends an increase in appropriation of \$93,730 for the Personnel Review Commission. This appropriation is needed for space maintenance charges. PRC was not previously charged for building space occupied and was accordingly not budgeted. Funding source is County General Fund.

G. General Fund		<b>JE427</b>
PJ100100 – Justice Affairs Administration		
Other Expenses	\$	(22,324.08)

The Office of Budget and Management is requesting an appropriation reduction for Public Safety Administration in the amount of \$22,324.08. This reduction is a result of an encumbrance carryover from 2020 which was not utilized and the purchase order has been decertified as of October 25, 2021. This expense was funded by the General Fund.

H. Community Development		<b>JE432</b>
DV220110 – Economic Development Fund		
Other Expenses	\$	7,000,000.00

The Office of Budget and Management, on behalf of the Department of Development, requests an appropriation increase in the Economic Development Fund in the amount of \$7,000,000. This increase will allow for the remaining payment to Sherwin Williams in the amount of \$7,000,000 per Council Resolution R2020-0047. Resolution R2020-0047 is a special large incentive grant in the amount of \$14,000,000 for the benefits of the Sherwin Williams Headquarters Project to be located in the City of Cleveland as well as the Research and Development Facility Project to be located in the City of Brecksville. The first \$7,000,000 was appropriated on the October 26, 2021 agenda on Resolution R2021-0240. The total payment of \$14,000,000 is expected to be disbursed by the end of November 2021. Even though funding for the Economic Development Fund comes from Economic Loan Repayments, this \$7,000,000 is being funded by the General Fund. (See JE425 of this same agenda).

I. Community Development		<b>E-17-UC-39-001</b>
DV220160 – Emergency Solutions Development		
Other Expenses	\$	(26,856.94)

The Department of Development is requesting an appropriation reduction in the amount of \$26,856.94 for the purpose of closing out the 2017 Emergency Solutions Grant award. This annual grant was used to assist individuals and families in quickly regaining stability in permanent housing after experiencing a housing crisis or homelessness. This grant was funded by the U.S. Department of Housing and Urban Development (CFDA

14.231) and covered the performance period of January 1, 2017, to December 31, 2018. 91% of the grant, or \$283,351.06 was spent. There is no cash balance to resolve.

J. Community Development		<b>DV181HUDESG</b>
DV220160 – Emergency Solutions Development		
Personal Services	\$	(4,476.03)
Other Expenses	\$	(9,450.00)

The Department of Development is requesting an appropriation reduction in the amount of \$13,926.03 for the purpose of closing out the 2018 Emergency Solutions Grant award. This annual grant was used to assist individuals and families in quickly regaining stability in permanent housing after experiencing a housing crisis or homelessness. This grant was funded by the U.S. Department of Housing and Urban Development (CFDA 14.231) and covered the performance period of January 1, 2018, to December 31, 2019. 96% of the grant, or \$300,132.97 was spent. There is no cash balance to resolve.

K. Victim Assistance		<b>2017-TA-AX-K012</b>
DR325100 – Victim Safety Enhancement		
Other Expenses	\$	(2,135.37)

Domestic Relations Court is requesting an appropriation reduction in the amount of \$2,135.37 for the purpose of closing out the FFY 2017 Mentor Court grant award. Domestic Relations Court, specifically its Domestic Violence Department, is among an elite group of nationwide Mentor Courts that serve as resources for courts across the country by facilitating peer-to-peer learning and providing examples of effective practices. Grant funds were used to cover costs associated with hosting site visits, linking up with courts that are facing similar challenges, and assisting in the implementation of best practices to respond effectively to difficult cases. This grant was funded by the U.S. Department of Justice (CFDA 16.029) and covered the performance period of October 1, 2017, to September 30, 2021. 95% of the grant, or \$38,864.63 was spent. There is no cash balance to resolve.

L. Other Legislative & Executive		<b>IN-20-PSF</b>
IN290115 – Innovation Grants		
Personal Services	\$	(8,081.08)
Other Expenses	\$	(5.63)

The Office of Innovation and Performance is requesting an appropriation reduction in the amount of \$8,086.71 for the purpose of closing out the 2020 Public Service Fellow grant award. This grant was used to pay the payroll and professional development costs of a fellow hosted by the Office of Innovation and Performance. This grant was funded by the Cleveland Foundation and covered the performance period of July 1, 2020, to August 31, 2021. 84% of the grant, or \$41,913.29 was spent. This grant was paid as an advanced payment; the remaining funds have been returned to the grantor.

M. Other Legislative & Executive		<b>11514</b>
FS290125 – Consumer Affairs Grants		
Other Expenses	\$	(3,409.74)

The Department of Consumer Affairs is requesting an appropriation reduction in the amount of \$3,409.74 for the purpose of closing out the 2020 Sears Consumer Protection

and Education Fund grant award. Grant funds were used to develop and test SCAMO, a BINGO-like game that teaches seniors about scams in an interactive game format they are already familiar with. This grant was funded by the Special Committee of the Sears Consumer Protection and Education Fund and covered the performance period of February 7, 2020, to October 31, 2021. 64% of the grant, or \$5,990.26 was spent. This grant was paid as an advanced payment; the remaining funds have been returned to the grantor.

N. Victim Assistance		<b>PJ-21-SVAA-JC</b>
PJ325115 – Juvenile Court Victim Advocate		
Personal Services	\$	15,030.00

The Department of Public Safety and Justice Services is requesting new appropriation in the amount of \$15,030 for the purpose of establishing the 2021-22 State Victims Assistance Act grant award. Grant funds will be used to cover a portion of payroll costs for the Juvenile System Advocate position assigned to cover Juvenile Court cases. This grant is funded by the Office of the Ohio Attorney General and covers the performance period of October 1, 2021, to September 30, 2022. This grant will be paid on a reimbursable basis and requires no cash match.

O. Other Judicial		<b>JC-21-ODYS-DC</b>
JC285165 – Juvenile Court Other Detention Grants		
Other Expenses	\$	9,644.98

Juvenile Court is requesting new appropriation in the amount of \$9,644.98 for the purpose of establishing a new grant award received from the Ohio Department of Youth Services. Grant funds will be used to purchase televisions, television carts, and iPads for use in the Juvenile Detention Center. Purchases must be made by December 31, 2021. This grant will be paid on a reimbursable basis and requires no cash match.

P. Other Judicial		<b>JC-21-COVID</b>
JC285160 – Juvenile Court Judicial Grants		
Other Expenses	\$	284,546.55

Juvenile Court is requesting new appropriation in the amount of \$284,546.55 for the purpose of establishing the 2021 Coronavirus Emergency Supplemental Funding grant award. Grant funds will be used to make purchases related to the COVID-19 response including personal protective equipment (PPE) and computer equipment to enable remote working capabilities. This grant is funded by the U.S. Department of Justice (CFDA 16.034), passed through the Ohio Department of Public Safety, and covers the performance period of March 1, 2020, to September 30, 2021. This grant will be paid on a reimbursable basis and requires no cash match.

Q. Capital Projects		<b>CFVAR0002601</b>
PW600100 – Capital Projects		
Other Expenses	\$	75,000.00

The Department of Public Works requests an appropriation increase in the amount of \$75,000 in the County Building Riot Damage Repairs capital project. This increase will cover repairs done to the Cuyahoga County buildings. The estimated cost of this project

is \$479,816.18 with \$375,837.03 expended to date. This project was included as part of the 2020 Capital Improvements Plan and is funded by the General Fund Capital Improvements Subsidy.

R. Capital Projects		<b>CFHAL0000401</b>
PW600100 – Capital Projects		
Other Expenses	\$	245,000.00

The Department of Public Works requests an appropriation increase in the amount of \$245,000 in the Prosecutor ICAC Relocation capital project. This increase will cover improvements and renovations for the Cuyahoga County Prosecutor’s Office ICAC unit. The estimated cost of this project is \$1,191,000 with \$775,255.83 expended to date. This project was included as part of the 2020 Capital Improvements Plan. This appropriation increase is funded by the General Fund Capital Improvements Subsidy.

S. Human Services		<b>JE434</b>
WF260110 – WF Innovation & Opportunities		
Other Expenses	\$	1,006,171,.96

The Office of Budget and Management, on behalf of the Department of Workforce Development, is requesting an appropriation increase in the amount of \$1,006,171.96. The funds represent additional WIOA Adult/Dislocated Worker funds and WIOA Youth funds to be used for Contractual Services. The need for this increase is based on subgrant reallocation of WIOA funds throughout the state. Workforce Innovation and Opportunity Act (WIOA) is a Federal Grant and revenue awards pass through the Ohio Department of Job and Family Services to the Department of Workforce Development.

**SECTION 2.** That the 2020/2021 Biennial Operating Budget for 2021 be amended to provide for the following appropriation transfers:

<u>Fund Nos./Budget Accounts</u>	<u>Journal Nos.</u>
A. FROM: General Fund	<b>JE430</b>
PD285100 – Public Defender – Cleve Munici	
Other Expenses	\$ 65,000.00
TO: Other Judicial	
PD285100 – Public Defender – Cleve Munici	
Personal Services	\$ 65,000.00

The Office of Budget Management, on behalf of the Public Defender, is requesting a transfer in the amount of \$65,000 for the purpose of covering expected flex benefits expenditures through the end of fiscal year 2021. The funding source is special revenue and generated on a reimbursement basis from the City of Cleveland per the agreement.

B. FROM: Community Development	<b>DV-21-CCBH-LHCG</b>
DV220150 – Lead Hazard Control	
Personal Services	\$ 2,498.40
TO: Community Development	

DV220150 – Lead Hazard Control		
Other Expenses	\$	2,498.40

The Department of Development is requesting an appropriation transfer in the amount of \$2,498.40 from personnel to other expenses to cover eligible meeting and training costs associated with the 2018-21 Lead Hazard Control Grant award. This grant is funded by the U.S. Department of Housing and Urban Development (CFDA 14.900), passed through the Cuyahoga County Board of Health. Grant funds are used predominantly to pay for staff time associated with determining program eligibility, inspecting units, writing specifications, and inspecting work done by contractors in pursuit of identifying and controlling lead hazards in private housing that is owned by or rented to low- or very-low-income families.

C. FROM: County Airport		<b>CAOPR0000501</b>
PW700200 – Airport Capital Projects		
Other Expenses	\$	10,000.00
TO: County Airport		
PW700200 – Airport Capital Projects		
Personal Services	\$	10,000.00

The Department of Public Works is requesting an appropriation transfer in the amount of \$10,000 from other expenses to personal services as part of the 2020 Apron Taxiway Replacement capital project. This transfer will enable the reimbursement of payroll costs up to the allowable amount of \$10,000.00. This project was included as part of the 2020 Capital Improvements Plan and is being funded 100% by the U.S. Department of Transportation, Federal Aviation Administration.

**SECTION 3.** That the 2020/2021 Biennial Operating Budget for 2021 be amended to provide for the following cash transfers between County funds:

<u>Fund Nos./Budget Accounts</u>		<u>Journal Nos.</u>
A. FROM: Sanitary Engineer		<b>GL2-00</b>
PW715300 – Sanitary Debt Service		
Trans Out – Transfer Out	\$	391,759.16
Sanitary Engineer		
PW715500 – Sanitary Construction		
Trans Out – Transfer Out	\$	10,261.72
TO: Debt Service		
FS500100 – Bond Retirement-General		
Trans In- Transfer In	\$	402,020.88

The Office of Budget and Management requests cash transfers of \$402,020.88 in sewer special assessments from the Sanitary Engineer Debt Service Funds to the General Obligation Debt Retirement Fund. Special assessments were levied for repayment of bonds issued to create and repair various sewers in the townships of Chagrin Falls and Olmsted. Bonds were originally issued in 2004 and refunded a number of times and

currently reside within the General Obligation Bonds Series 2020, issued in 2020. Funding source is sewer special assessment revenue within the Sanitary Engineer Funds.

B. FROM: Motor Vehicle Gas Tax	<b>GL3-00</b>
PW270205 – Administration	
Trans Out – Transfer Out	\$ 6,173,788.61
Motor Vehicle Gas Tax	
PW270200 – Road Capital Improvements	
Trans Out – Transfer Out	\$ 3,353,831.94
TO: Road Capital Projects	
PW605100 – ODOT-LPA	
Trans In- Transfer In	\$ 1,006,451.63
Road Capital Projects	
PW605105 – OH Dept of Pub Wrks Integrating	
Trans In- Transfer In	\$ 3,488,421.27
Motor Vehicle Gas Tax	
PW270210 – \$5.00 HB26 R&BCap. Imp.	
Trans In- Transfer In	\$ 5,032,747.65

The Department of Public Works requests cash transfers from the \$7.50 fund to the new \$5.00 fund, and the \$7.50 fund and \$5.00 fund to the ODOT projects and OPWC projects that have sold this year. The State of Ohio sends by EFT the revenue for the New \$5.00 fund combined with the \$7.50 fund. Therefore a cash transfer in the amount of \$5,032,747.65 from the \$7.50 fund to the New \$5.00 fund is being requested. The remaining cash transfer will cover the County's share for the following projects: Cedar Point Bridge in the amount of \$611,096.12 (Total Project Cost \$3,055,481), St Clair Bridge in the amount of \$395,355.51 (Total Project Cost \$1,976,778), York Road in the amount of \$2,347,380.31 (Total Project Cost \$4,008,200), and Green Road Bridge in the amount of \$1,141,040.96 (Total Project Cost 3,928,758). The current cash balance in the \$7.50 and \$5.00 Fund is \$54,966,132.00.

C. FROM: County Parking Garage	<b>GL4-00</b>
PW705100 – County Parking Garage	
Trans Out – Transfer Out	\$ 1,211,625.00
TO: General Fund	
FS100900 – Non-Departmental Rev/Exp	
Trans In- Transfer In	\$ 1,209,625.00
Debt Service	
FS500160 – 2017 Sales Tax Bonds	
Trans In- Transfer In	\$ 2,000.00

The Department of Public Works requests a cash transfer to reimburse the General Fund for debt service payments made for renovations at the Huntington Park Garage and a \$2,000 trustee fee. Funding comes from parking fees paid by employees and the public.

The debt repayment schedule has two payments per year totaling approximately \$1.5 million annually through 2037, and this cash transfer would cover the payment due January 1, 2022. The cash balance in the County Parking Garage fund is \$6,018,158.

D. FROM: General Fund		<b>GL9-00</b>
FS100350 – General Fd Operating Subsidies		
Trans Out – Transfer Out	\$	7,000,000.00
TO: Community Development		
DV220110 – Economic Development Fund		
Trans In- Transfer In	\$	7,000,000.00

The Office of Budget and Management requests a cash transfer from the General Fund Subsidy Account to the Department of Developments Economic Fund in the amount of \$7,000,000 to cover the remaining balance of the payment from the Economic Development Fund to Sherwin Williams per Resolution R2020-0047. Resolution R2020-0047 is a special large incentive grant in the amount of \$14,000,000 for the benefits of the Sherwin Williams Headquarters Project to be located in the City of Cleveland as well as the Research and Development Facility Project to be located in the City of Brecksville. The breakdown of funding is \$5,000,000 from the Economic Development Fund, \$2,000,000 from the Community Development Fund (See JE425 of this same agenda), and \$7,000,000 from the General Fund Reserves. Therefore, this cash transfer fulfills the General Fund portion of Resolution R2020-0047.

**SECTION 4.** It is necessary that this Resolution become immediately effective for the usual daily operation of the County; the preservation of public peace, health, or safety in the County; and any additional reasons set forth in the preamble. Provided that this Resolution receives the affirmative vote of at least eight members of Council, it shall take effect and be in force immediately upon the earliest occurrence of any of the following: (1) its approval by the County Executive through signature, (2) the expiration of the time during which it may be disapproved by the County Executive under Section 3.10(6) of the Cuyahoga County Charter, or (3) its passage by at least eight members of Council after disapproval pursuant to Section 3.10(7) of the Cuyahoga County Charter. Otherwise, it shall take effect and be in force from and after the earliest period allowed by law.

**SECTION 5.** It is found and determined that all formal actions of this Council relating to the adoption of this Resolution were adopted in an open meeting of the Council, and that all deliberations of this Council and of any of its committees that resulted in such formal action were in meetings open to the public, in compliance with all legal requirements, including Section 121.22 of the Ohio Revised Code.

On a motion by \_\_\_\_\_, seconded by \_\_\_\_\_, the foregoing Resolution was duly adopted.

Yeas:

Nays:

\_\_\_\_\_  
County Council President

\_\_\_\_\_  
Date

\_\_\_\_\_  
County Executive

\_\_\_\_\_  
Date

\_\_\_\_\_  
Clerk of Council

\_\_\_\_\_  
Date

Journal CC044  
November 09, 2021





To: Andria Richardson, Clerk of County Council

From: Walter Parfejewiec, Office of Budget and Management

Date: November 1, 2021

Re: Fiscal Agenda – 11/9/2021 - Proposed

cc: Michael Chambers, Fiscal Office; Mary Louise Madigan, Communications

The Office of Budget & Management requests that the members of County Council consider the attached fiscal resolution for approval on first reading at the meeting on **November 9, 2021**. The requested fiscal items, including additional appropriations, appropriation transfers, and cash transfers, are necessary to reconcile the originally adopted 2020 Budget. Items of note on this agenda include:

- Request to provide appropriation increase/decrease as requested.
- Request grant appropriation and closeouts.
- Request to provide appropriation transfers as requested.
- Request to provide cash transfers as requested.

**Additional Appropriation Summary** – Additional appropriation is requested to cover expenditures that exceed the original estimate and must be supported by a revenue source. A reduction in appropriation is requested in conjunction with the close-out of a program, grant, or decertification of an encumbrance.

Department	Amount Requested	Item	Funding Source	Purpose
Fiscal Office	\$190,000.00	A	General Fund	Appropriation Increase
Sustainability	\$10,000.00	B	Special Revenue – No General/HHS Levy Fund Impact	Appropriation Increase
Executive	\$12,531.00	C	General Fund	Appropriation Increase
Public Works	\$9,527,620.55	D	Special Revenue – No General/HHS Levy Fund Impact	Appropriation Increase

Office of Budget and Management	\$7,000,000.00	E	General Fund	Appropriation Increase
Personnel Review Commission	\$93,730.00	F	General Fund	Appropriation Increase
Public Safety and Justice Services	\$ (22,324.08)	G	General Fund	Appropriation Decrease
Development	\$7,000,000.00	H	General Fund	Appropriation Increase
Development	\$ (40,782.97)	I-J	Grant – No General/HHS Levy Fund Impact	Grant Closeout
Domestic Relations	\$ (2,135.37)	K	Grant – No General/HHS Levy Fund Impact	Grant Closeout
Innovation and Performance	\$ (8,086.71)	L	Grant – No General/HHS Levy Fund Impact	Grant Closeout
Fiscal Office-Consumer Affairs	\$ (3,409.74)	M	Grant – No General/HHS Levy Fund Impact	Grant Closeout
Public Safety and Justice Services	\$15,030.00	N	Grant – No General/HHS Levy Fund Impact	Grant Appropriation
Juvenile Court	\$294,546.55	O-P	Grant – No General/HHS Levy Fund Impact	Grant Appropriation
Public Works	\$320,000.00	Q-R	CIP-General Fund	Appropriation Increase
Workforce Development	\$1,006,171.96	S	PA Fund – No General/HHS Levy Fund Impact	Appropriation Increase

**Appropriation Transfer Summary** – Transfers between budget accounts in the same fund or between different resolution categories within the same budget account.

Department	Amount Transferred	Item	Funding Source	Purpose
Public Defender	\$65,000.00	A	Special Revenue – No General/HHS Levy Fund Impact	Appropriation Transfer
Development	\$2,498.40	B	Grant – No General/HHS Levy Fund Impact	Appropriation Transfer
Public Works	\$10,000.00	C	Special Revenue – No General/HHS Levy Fund Impact	Appropriation Transfer

**Cash Transfer Summary** – Operating transfers support operating expenditures transfer cash from one fund to another. Transfers post as an expenditure and sufficient appropriation must be available to process the transaction.

<b>Department</b>	<b>Amount Transferred</b>	<b>Item</b>	<b>Funding Source</b>	<b>Purpose</b>
Sanitary Engineer	\$402,020.88	A	Special Revenue – No General/HHS Levy Fund Impact	Cash Transfer
Public Works	\$9,527,620.55	B	Special Revenue – No General/HHS Levy Fund Impact	Cash Transfer
Public Works	\$1,211,625.00	C	Special Revenue – No General/HHS Levy Fund Impact	Cash Transfer
Office of Budget and Management	\$7,000,000.00	D	General Fund	Cash Transfer

# County Council of Cuyahoga County, Ohio

## Resolution No. R2021-0249

<p>Sponsored by: <b>County Executive Budish/Departments of Law and Public Works/Sanitary Sewer Division</b></p>	<p><b>A Resolution</b> approving a Collective Bargaining Agreement between Cuyahoga County and Laborers’ International Union of North America, Local 860, representing approximately 68 employees in 3 classifications in the Department of Public Works/Sanitary Sewer Division for the period 1/1/2021 - 12/31/2023; directing that funds necessary to implement the Collective Bargaining Agreement be budgeted and appropriated; authorizing the County Executive to execute the agreement and all other documents consistent with this Resolution; and declaring the necessity that this Resolution become immediately effective.</p>
---	--

WHEREAS, the Cuyahoga County Department of Law has been engaged in negotiations with Laborers’ International Union of North America, Local 860, in an effort to negotiate a new successor collective bargaining agreement (“CBA”) that includes approximately 68 full time employees in 3 classifications in the Cuyahoga County Department of Public Works/Sanitary Sewer Division; and,

WHEREAS, the Laborers’ International Union of North America, Local 860, bargaining unit represents sewer maintenance workers, operators and leadmen within the Department of Public Works/Sanitary Sewer Division; and

WHEREAS, the parties have engaged in good faith negotiations and have reached a tentative agreement on a successor collective bargaining agreement; and,

WHEREAS, on October 28, 2021, the members of the bargaining unit voted to ratify the proposed successor collective bargaining agreement; and,

WHEREAS, O.R.C. 4117.10 (B) requires that a public employer submit a request for funds necessary to implement an agreement, and for approval of any other matter requiring the approval of the appropriate legislative body to the legislative body within thirty days of the date on which the parties finalize the agreement, unless otherwise specified or if the legislative body is not in session at the time, then within fourteen days after it convenes; and,

WHEREAS, O.R.C. 4117.10(B) further states that the legislative body must approve or reject the submission as a whole, and the submission is deemed approved if the legislative body fails to act within thirty days after the public employer submits the agreement; and,

WHEREAS, the Department of Law, the County Executive and the Department of Public Works are recommending that Council approve the proposed Collective Bargaining Agreement; and,

WHEREAS, it is necessary that this Resolution become immediately effective to ensure the efficient operation of the Cuyahoga County Department of Public Works.

**NOW, THEREFORE, BE IT RESOLVED BY THE COUNTY COUNCIL OF CUYAHOGA COUNTY, OHIO:**

**SECTION 1.** The Cuyahoga County Council hereby approves the Collective Bargaining Agreement between Cuyahoga County and Laborers' International Union of North America, Local 860, representing approximately 68 employees in 3 classifications in the Department of Public Works/Sanitary Sewer Division for the period 1/1/2021 - 12/31/2023, and authorizes the County Executive to execute all documents consistent with this Resolution.

**SECTION 2.** Funds necessary to implement the CBA between the County and Laborers' International Union of North America, Local 860, shall be budgeted and appropriated.

**SECTION 3.** It is necessary that this Resolution become immediately effective for the usual daily operation of the County; the preservation of public peace, health, or safety in the County; and any additional reasons set forth in the preamble. Provided that this Resolution receives the affirmative vote of at least eight (8) members of Council, it shall take effect and be in force immediately upon the earliest occurrence of any of the following: (1) its approval by the County Executive through signature, (2) the expiration of the time during which it may be disapproved by the County Executive under Section 3.10(6) of the Cuyahoga County Charter, or (3) its passage by at least eight members of Council after disapproval pursuant to Section 3.10(7) of the Cuyahoga County Charter. Otherwise, it shall take effect and be in force from and after the earliest period allowed by law.

**SECTION 4.** It is found and determined that all formal actions of this Council relating to the adoption of this Resolution were adopted in an open meeting of the Council, and that all deliberations of this Council and of any of its committees that resulted in such formal action were in meetings open to the public, in compliance with all legal requirements, including Section 121.22 of the Ohio Revised Code.

On a motion by \_\_\_\_\_, seconded by \_\_\_\_\_, the foregoing Resolution was duly adopted.

Yeas:

Nays:

\_\_\_\_\_  
County Council President

\_\_\_\_\_  
Date

\_\_\_\_\_  
County Executive

\_\_\_\_\_  
Date

\_\_\_\_\_  
Clerk of Council

\_\_\_\_\_  
Date

Journal CC044  
November 6, 2021

# County Council of Cuyahoga County, Ohio

## Resolution No. R2021-0250

Sponsored by: <b>County Executive Budish</b>	<b>A Resolution</b> confirming the County Executive’s reappointment of various individuals to serve on the Cuyahoga County Board of Developmental Disabilities for the term 1/27/2022 – 1/22/2026; and declaring the necessity that this Resolution become immediately effective.
--	---

WHEREAS, pursuant to Ohio Revised Code Section 5126.02, the County of Cuyahoga shall have its own county board of developmental disabilities; and

WHEREAS, pursuant to the provisions in Ohio Revised Code Section 5126.021, the Cuyahoga County Board of Developmental Disabilities consists of seven members. Five members are appointed by the County and two members are appointed by the Probate Court; and

WHEREAS, members appointed to fill a vacancy in the Cuyahoga County board of Developmental Disabilities shall service a term of four years; and

WHEREAS, the Cuyahoga County Charter Section 6.04, entitled Special Boards and Commissions, states that “[w]hen general law or any agreement with another public agency or court order provides for appointment of members of a special board or commission or other agency by the board of county commissioners, such appointment shall be made by the County Executive, subject to confirmation by the Council,” and

WHEREAS, the County Executive has nominated the following individuals to serve on the Cuyahoga County Board of Developmental Disabilities for the term 1/27/2022 – 1/22/2026:

- 1) Reappointments:
  - a. Lisa M. Hunt
  - b. Mozelle Jackson

WHEREAS, this Council by a vote of at least eight (8) members determines that it is necessary that this Resolution become immediately effective in order that Charter requirements can be complied with and critical services provided by Cuyahoga County can continue and to provide for the usual, daily operation of a County Board.





First Reading/Referred to Committee:  
Committee(s) Assigned:

Journal \_\_\_\_\_  
\_\_\_\_\_, 20\_\_



October 19, 2021

Pernel Jones, Jr., President  
Cuyahoga County Council  
2079 E. Ninth Street, 8<sup>th</sup> Floor  
Cleveland, OH 44115

Re: Cuyahoga County Board of Developmental Disabilities

Dear President Jones:

Pursuant to the provisions found in Ohio Revised Code Section 5126, I submit the following nominees for reappointment to the Cuyahoga County Board of Developmental Disabilities:

- **Lisa M. Hunt**, 4-year term, 01/27/2022 – 01/22/2026
  - Reappointment
  - Currently resides in Highland Hills (Cuyahoga County)
- **Mozelle Jackson**, 4-year term, 01/27/2022 – 01/22/2026
  - Reappointment
  - Currently resides in Solon (Cuyahoga County)

The Board of Developmental Disabilities is composed of seven members. Five of the members are appointed by the County and two are appointed by the Probate Court. The Board helps to establish policies to assist children and adults with developmental disabilities so they can live, learn, work and play in our community. Also, the Board and the policies it enacts, play a pivotal role in providing needed resources and assistance for families who have family members receiving services from this body.

The nominee's resumes have been attached for your review.

There are no known conflicts of interest for which an advisory opinion has been requested. This board is uncompensated. There are (14) candidates on file for this position.

Thank you for your consideration of these appointments. Should you or any of your colleagues have any questions, please feel free to contact Michele Pomerantz in my office at 216-443-7125.

Sincerely,

Armond Budish  
County Executive



September 2, 2021

Armond Budish  
Office of the County Executive  
2079 East Ninth Street  
Cleveland, OH 44115

Re: Cuyahoga DD Board Members – two members' terms expiring 1/27/22

Dear Mr. Budish:

I am writing concerning our seven-member DD Board and to advise you that the terms of two of our Cuyahoga County appointed members will expire on the date of our organizational meeting in January 2022. The Board members listed below have performed well, have expressed interest in serving again, and we would be pleased to have them reappointed.

- Lisa M. Hunt will complete two four-year terms and is eligible to serve a third term. She has been an active member and currently fills the role as our Board president. Ms. Hunt has a son with a developmental disability who is eligible to receive services from Cuyahoga DD.
- Mozelle T. Jackson will be completing her first four-year term and is eligible to serve again. She has a wealth of financial experience and has been invaluable in guiding our Board. Ms. Jackson's son receives supports from Cuyahoga DD, therefore she fulfills the requirement of ORC 5126.022 for appointing a member with an immediate family member eligible to receive adult services from our Board.

I have attached for your convenience the Ohio Revised Code sections pertaining to appointments to county boards of developmental disabilities. According to the ORC section 5126.025, appointments must be completed by November 30, 2021. Please let me know if we can be of assistance in the process of reappointing these valued members of our Board. Thank you.

Sincerely,

A handwritten signature in blue ink that reads "Kelly A. Petty".

Kelly A. Petty  
Superintendent & CEO

cc: with attachments: Michele Pomerantz



1275 Lakeside Avenue • Cleveland, OH 44114-1129 • (216) 241-8230 • Fax (216) 861-0253

Lisa M. Hunt, *President* • Cynthia V. Schulz, *Vice President* • Mozelle T. Jackson, *Secretary*  
Allison R. Frazier • Steven M. Licciardi • Alaina N. McCruel • Stephen M. Scheidt



## Ohio Revised Code

### Section 5126.022 Appointment of members of county boards.

Effective: October 12, 2016

Legislation: House Bill 158 - 131st General Assembly

When making appointments to a county board of developmental disabilities, an appointing authority shall do all of the following:

(A) Appoint only individuals who are residents of the county the appointing authority serves, citizens of the United States, and interested and knowledgeable in the field of intellectual disabilities and other allied fields;

(B) If the appointing authority is a board of county commissioners, appoint at least two individuals who are eligible for services provided by the county board or are immediate family members of such individuals. The board of county commissioners shall, whenever possible, ensure that one of those two members is an individual eligible for adult services or an immediate family member of an individual eligible for adult services and the other is an immediate family member of an individual eligible for early intervention services or services for preschool or school-age children;

(C) If the appointing authority is a senior probate judge, appoint at least one individual who is an immediate family member of an individual eligible for residential services or supported living;

(D) Appoint, to the maximum extent possible, individuals who have professional training and experience in business management, finance, law, health care practice, personnel administration, or government service;

(E) Provide for the county board's membership to reflect, as nearly as possible, the composition of the county that the county board serves.



## Ohio Revised Code

### Section 5126.025 Time and term of appointment of members of board.

Effective: October 6, 2009

Legislation: Senate Bill 79 - 128th General Assembly

Except for members appointed under section 5126.027 of the Revised Code to fill a vacancy, members of a county board of developmental disabilities shall be appointed or reappointed not later than the last day of November, commence their terms on the date of the stated annual organizational meeting in the following January as provided under section 5126.029 of the Revised Code, and serve terms of four years. The membership of an individual appointed as an immediate family member of a recipient of services shall not be terminated because the services are no longer received.

# Lisa M. Hunt

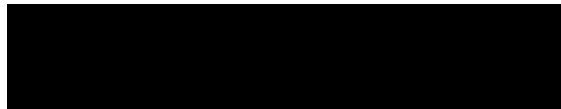

Strong, versatile and creative leader seeks opportunity to use administrative skills, artistic acumen, education and advocacy to aid in organizational and professional growth in today's diverse, global marketplace.

## WORK EXPERIENCE

2017- Current      Cleveland Hts. - University Hts. City Schools      Cleveland Heights, OH

### **Family Engagement Specialist**

Responsible for developing programs, practices and resources that build partnerships in support of CH-UH students, families and staff to increase academic success and whole child development; Coordinate family educational supports; Provide technical support and consultation around best-practices; Manage the District's Family Engagement Advisory Groups; Manage implementation of National Network of Partnership Schools; Co-Founder of FACE Collaborative a regional learning community for practitioners; Co-lead of District Equity Task Force; Minority Student Achievement Network (MSAN) District Regional Practitioners Council (RPC); Member of several District Task Forces including the Grading, Discipline, Kindergarten Readiness committees.

2009- 2017      Reaching Heights      Cleveland Heights, OH

### **Assistant Director**

Managed and evaluated all k-12 parent/community engagement programs; designed and developed community collaboration teams across 12 schools; created and led parent group to build special education advocacy network to bolster equity and access; volunteer management, recruiting and recognition; website and social media manager; coordinated annual fundraisers; assist with development and grants; built essential stakeholder relationships.

2006-2009      Broadway School of Music & the Arts      Cleveland, OH

### **Dance Educator**

2009-2012      Cleveland State University      Cleveland, OH

### **Graduate Assistant – Dance Department**

Coordinated and supported campus dance activities; assisted in audition process and selection; developed and distributed promotional materials; managed communication with current and potential students; marketed dance minor; student representative for campus recruiting events; database and archive management.

Summer 2007-2009      Rainey Institute      Cleveland, OH

### **Cleveland Foundation Summer Internship**

Developed summer camp measurement protocol consisting of formative and summative assessments; using cohort of 145+ attendees captured program impact; created, administered and compiled summer camp survey data for staff, parents, counselors and camp attendees; gained 44+ hours of intensive professional development with local non-profit and business sectors.

2006-2008      Cleveland State University - Center for Health Equity      Cleveland, OH

### **Dance Coordinator**

Dance and movement facilitator for Community-based Participatory Research Modules for at-risk youth; co-presented workshops on healthy, active, adaptive behaviors with a team of social workers, physical educators, dieticians and healthcare specialists; planned community activities; recorded and presented qualitative findings and methods for sustainability.

**Administrative Assistant**

2001-2003                      The Lipson Group

Cleveland, OH

**EDUCATION**

**Cornell University**

Ithaca, NY

2021 - eCornell - Diversity and Inclusion Certification

**Harvard Graduate School of Education**

Cambridge, MA

2019 Family Engagement in Education

**Cleveland State University**

Cleveland, OH

2012 - M.S. Master's of Nonprofit Administration and Leadership

2009 - B.A. in Urban Studies –Nonprofit Administration and Leadership

Cum Laude. Contemporary Dance Minor.

**ACCOMPLISHMENTS  
AND SKILLS**

City of Cleveland Heights Social Justice and Equity Task Force - Member 2021; Cuyahoga County Board of Developmental Disabilities - Board President; Center for Creative Leadership Solutions - Equity Certification; Cleveland Hts. – University Hts.; The Institute for Educational Leaderships'(IEL)- District Leaders Network Member; National Association for Family School and Community Engagement Member; Family Engagement Leaders of Ohio (FELO) Member; CH-UH 2016 Levy Campaign; 2014-2016 CH-UH PTA Council - Vice President; National Dance Guilds' Community Arts in Education Leadership Institute (CAELI); Exceptional Children's Advocacy Group -Founder 2013; Cleveland Foundation Scholarship Selection Committee Member 2012-2017; Heights Youth Theatre - Board President 2012-2017; Google Suite; Constant Contact, Microsoft Office and social networking proficient; Dynamic public speaker; Excellent verbal and written communication; Task oriented and results driven; Excellent team member; Choreographer, dancer, film and stage actor; demonstrated creative leader.



## LISA M. HUNT

was born and raised in Cleveland, Ohio and spent over ten years in Washington DC growing as an administrator, artist and leader.

She prides herself on being a Cleveland native, and a servant leader who sees solutions and works hard to solve problems. Her understanding of leadership and a love for the study of contemporary dance was cultivated at Cleveland State University. There she received a master's in nonprofit administration and leadership (MNAL) with a minor in dance aided by numerous leaders and luminaries. Ms. Hunt believes in approaching her work artistically knowing that the arts push you past your comfort zone and requires you to see the unimaginable, and work in concert across diversity, time and space. Currently serving as the first Family Engagement Specialist for the CH-UH City Schools, she embraces it as a calling and is passionate about schools, families and communities. She appreciates collaborating and developing opportunities for learning and leading capacity-building initiatives that strengthen partnerships. Ms Hunt has enjoyed performing at Cleveland's Playhouse Square Center, Cain Park and Tri C and has presented at numerous statewide and national conferences on equity and family engagement. Ms. Hunt is committed to understanding and increasing awareness for diversity, equity, inclusion and justice. Guided by the belief that "faith is the substance of things hoped for and the evidence of things not seen," she is grateful for that faith that helped her raise two incredible sons, [REDACTED]





Mozelle Jackson

Vice President, Chief Financial Officer and Treasurer

Make-A-Wish America

**Mozelle Jackson** is a Senior Executive with 25+ years of strategic, financial, and operational experience in a variety of industries with global public, private and PE-owned companies. Her background includes leadership of Finance and Accounting, Operations, HR, IT, purchasing, ERM, legal, process improvement and revenue generation. Her industry experience includes manufacturing, distribution, financial technology, banking and sports and entertainment. She has had significant experience in building infrastructures for companies that allow for fast-paced growth, along with ensuring that cash flow supports company growth and investments, aligning and reporting on metrics that drive the business, M&A activity, including due diligence, integration, and identification of synergies as well as debt financing / refinancing experience.

Mozelle currently serves as the Vice President, Chief Financial Officer and Treasurer at Make-A-Wish America (National Office). Make-A-Wish operates as a Federated model with 59 Chapters across the United States. Make-A-Wish creates life-changing wishes for children with critical illnesses. She is responsible for Finance/Accounting, Strategy, Investments, Compliance, Enterprise Risk Management, Process Improvement and Facilities. Mozelle works closely with the National Office leadership team as well as with the CEOs, Operations and Finance professionals across the 59 Chapters and also works with Make-A-Wish International.

Prior to joining Make-A-Wish America, Mozelle was the Vice President of Global Finance of Diebold Nixdorf, Incorporated, a \$4.5 billion NYSE listed company (DBD) with 23,000+ employees and 100+ locations globally headquartered in North Canton, Ohio. She managed DBD's business finance, including strategic decision analysis, management reporting, board reporting, business support for all earnings and financing, cash flow management and performance analysis. Mozelle also led the finance transformation, where she was responsible for identifying and executing initiatives to become a world-class Finance organization.

Previously Mozelle served as the EVP, Chief Financial and Administrative Officer at Cavaliers Holdings, LLC, a 2,000 employee, privately held sports and entertainment company operating multiple sports properties and facilities that were ranked one of the most active venues in the world. During her 8 years at Cavaliers Holdings, LLC, she managed accounting/finance, facility operations (maintenance of all the venues, security, guest services and housekeeping), booking, legal, human resources, engagement, and inclusion, ERM, sourcing and process improvement. She partnered with the RNC Committee on arrangements to execute a flawless Republican National Convention. Mozelle led multiple financings providing cash flow flexibility to meet multiple operating priorities while balancing investment needs. She also led the improvement in fan / customer experience through Disney's Elevate Program delivered to 2,200, including 3<sup>rd</sup> party partners (police, concessionaires, parking).

Mozelle served as the Chief Financial Officer for Elyria Foundry a \$150 million PE owned firm of highly engineered gray and ductile iron castings during the tenure of 4 CEOs. She led a \$100 million bond placement, which effectively required the company to report as if a public company to its bondholders. She led the due diligence and worked closely with the PE firm on a substantial acquisition and identified synergistic cost savings opportunities post acquisition.

Mozelle's earlier roles include SVP, of Fifth Third Northeastern Ohio which had \$16 billion of assets, \$1.5 billion of net revenue and included oversight of 6 different affiliate markets. She led as President, the turnaround of a privately held plastic injection molding business managing strategy, sales, marketing, manufacturing (plastic injection molding), supply chain, finance, human resources, research and development and quality. Mozelle served Vice President, Finance at Corpro Companies, Inc. a \$200 million NYSE global provider of corrosion control engineering services, systems, and equipment where her responsibilities included building an infrastructure that would support the fast growth of the business, due diligence and integration of acquisitions, management and SEC reporting. Mozelle began her career at Arthur Andersen in the Cleveland office.

Mozelle currently serves on the Board of Directors of The Achievement Centers for Children, Cuyahoga County Board of Developmental Disabilities and serves as the outside advisor to the Audit Committee of The Cleveland Foundation, in which role she has full voting rights.

Her formal qualifications include a BBA from Cleveland State University and a CPA.

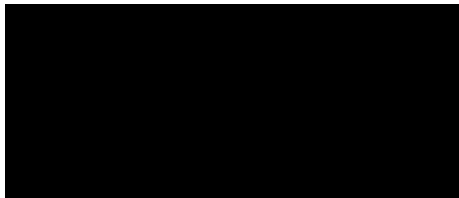

March 22nd 2021	Board of Developmental Disabilities	Ebony Spano	Mayfield Heights
June 12th 2020	Board of Developmental Disabilities	Ebony Spano	Cleveland
Oct. 20th 2020	Board of Developmental Disabilities	Janet Carpenter	Bay Village
Nov. 10th 2020	Board of Developmental Disabilities	Cynthia Schulz	Middleburg Heights
Nov. 10th 2020	Board of Developmental Disabilities	Steven M Licciardi	Bratenahl
Nov. 28th 2020	Board of Developmental Disabilities	Kim Thomas	Richmond Heights
Dec. 8th 2020	Board of Developmental Disabilities	Richard Montgomery	Euclid
Feb. 3rd 2021	Board of Developmental Disabilities	Shreya Modi	Orange
Feb. 4th 2021	Board of Developmental Disabilities	Alaina McCruel	Fairview Park
Feb. 5th 2021	Board of Developmental Disabilities	Pines Deborah	Solon
Feb. 15th 2021	Board of Developmental Disabilities	Jeromey Barksdale	Cleveland
March 3rd 2021	Board of Developmental Disabilities	Ebony Spano	Mayfield Heights
Sept. 23 2021	Board of Developmental Disabilities	Lisa Hunt	Highland Hills
Oct. 19th 2021	Board of Developmental Disabilities	Mozelle Jackson	Solon

# County Council of Cuyahoga County, Ohio

## Resolution No. R2021-0251

Sponsored by: <b>County Executive Budish</b>	<b>A Resolution</b> confirming the County Executive’s appointment of Karolyn Isenhart to serve on the Cuyahoga Arts and Culture Board of Trustees for an unexpired term ending 3/31/2024; and declaring the necessity that this Resolution become immediately effective.
--	--

WHEREAS, pursuant to Ohio Revised Code Chapter 3381, a regional arts and cultural district was established in Cuyahoga County to provide programs and activities in areas directly concerned with the arts or cultural heritage; and

WHEREAS, such regional arts and cultural district is governed by a Board of Trustees called the Cuyahoga Arts and Culture Board of Trustees consisting of five (5) members having broad knowledge and experience in the arts or cultural heritage and shall have other qualifications as outlined in the by-laws; and

WHEREAS, pursuant to Ohio Revised Code Section 3381.05, the Board of Trustees shall be appointed to a three (3) year term; and

WHEREAS, the Cuyahoga County Charter Section 6.04, entitled Special Boards and Commissions, states that “[w]hen general law or any agreement with another public agency or court order provides for appointment of members of a special board or commission or other agency by the board of county commissioners, such appointment shall be made by the County Executive, subject to confirmation by the Council;” and

WHEREAS, the County Executive has nominated Karolyn Isenhart (replacing Gary Hanson) to be appointed to serve on the Cuyahoga Arts and Culture Board of Trustees for an unexpired term ending 3/31/2024; and

WHEREAS, this Council by a vote of at least eight (8) members determines that it is necessary that this Resolution become immediately effective in order that Charter requirements can be complied with and critical services provided by Cuyahoga County can continue, and to provide for the usual, daily operation of a County Board.

**NOW, THEREFORE, BE IT RESOLVED BY THE COUNTY COUNCIL OF CUYAHOGA COUNTY, OHIO:**

**SECTION 1.** The Council of Cuyahoga County hereby confirms the County Executive's appointment of Karolyn Isenhart (replacing Gary Hanson) to serve on the Cuyahoga Arts and Culture Board of Trustees for an unexpired term ending 3/31/2024.

**SECTION 2.** It is necessary that this Resolution become immediately effective for the usual daily operation of the County; the preservation of public peace, health, or safety in the County; and any additional reasons set forth in the preamble. Provided that this Resolution receives the affirmative vote of eight members of Council, this Resolution shall become immediately effective.

**SECTION 3.** It is found and determined that all formal actions of this Council concerning and relating to the adoption of this Resolution were adopted in an open meeting of the Council, and that all deliberations of this Council and of any of its committees that resulted in such formal action were in meetings open to the public, in compliance with all legal requirements, including Section 121.22 of the Ohio Revised Code.

On a motion by \_\_\_\_\_, seconded by \_\_\_\_\_, the foregoing Resolution was duly adopted.

Yeas:

Nays:

\_\_\_\_\_  
County Council President

\_\_\_\_\_  
Date

\_\_\_\_\_  
Clerk of Council

\_\_\_\_\_  
Date

First Reading/Referred to Committee:

Committee(s) Assigned:

Journal \_\_\_\_\_  
\_\_\_\_\_, 20\_\_\_\_



November 3, 2021

Pernel Jones, Jr., President  
Cuyahoga County Council  
2079 E. Ninth Street, 8<sup>th</sup> Floor  
Cleveland, OH 44115

Re: Cuyahoga Arts and Culture (CAC) Board of Trustees

Dear President Jones,

I submit the following nomination for appointment to the Cuyahoga Arts and Culture (CAC) Board of Trustees:

- **Karolyn Isenhardt**, unexpired term on 3/31/2024
  - Replacing Gary Hanson
  - Currently resides in Lakewood (Cuyahoga)

Cuyahoga Arts & Culture (CAC) is authorized by Ohio Revised Code Chapter 3381. The CAC is the public funder for arts & culture events and, has awarded over 1,200 grants, to more than 300 organizations serving Cuyahoga County residents. The Board consists of five members appointed by the County Executive, subject to Council confirmation. ORC 3381.05 outlines the qualifications for trustees as a set of persons who:

- Have broad knowledge and experience in the arts or cultural heritage;
- At least two members...shall be persons who devote a major portion of their time to practicing, performing, or teaching any of the arts or who are professional administrators in any field of the arts or cultural heritage;
- Shall be qualified electors in Cuyahoga County.

A copy of Ms. Isenhardt's resume is attached. There are no known conflicts of interest for which an advisory opinion has been requested. This board is uncompensated. There are six candidates on file for this position.

Thank you for your consideration of these appointments. Should you or any of your colleagues have any questions, please feel free to contact Michele Pomerantz in my office at 216-443-7125.

Sincerely,

Armond Budish  
County Executive



### Top Skills

- Auctioneering
- Marketing Communications
- Marketing Management

# Karolyn Isenhardt

**Project Manager | Digital Events at Endeavor Business Media**  
Greater Cleveland

## Experience

**Endeavor Business Media**  
**Project Manager | Digital Events**  
October 2019 - Present (2 years 2 months)

**Rachel Davis Fine Arts**  
**Associate Auctioneer**  
September 2001 - Present (20 years 3 months)

**Big Blue Graphics**  
**Graphic Designer**  
July 2001 - Present (20 years 5 months)

**Karolyn Isenhardt, Auctioneer**  
**Auctioneer**  
December 1998 - Present (23 years)

Conducting auctions of fine art, antiques and estates.  
Conducting benefit auctions for organizations including:  
Cleveland Animal Protective League Fur Ball (2009-2019)  
WVIZ/ideaStream (2016, 2017)  
Ruffing Montessori Gala (2016)  
National Kidney Foundation-Cleveland Dining with the Stars (2015)  
Friends of the Cleveland Kennel Art Fur Animals (2015)  
Human Rights Campaign-Cleveland Gala (2008-2014)  
One Health Organization, ArtCares and Co-auctioneer for numerous events including Regina High School and The Rock and Roll Hall of Fame and Museum.

**Penton**  
3 years 3 months  
**Project Manager | Digital Events**  
August 2016 - October 2019 (3 years 3 months)  
Cleveland, Ohio

**Project Manager**

August 2016 - October 2019 (3 years 3 months)

Xerox

Learning and Development Analyst

April 2010 - May 2016 (6 years 2 months)

Cleveland, Ohio

Ulmer & Berne LLP

Marketing & Recruiting Coordinator

July 2001 - November 2008 (7 years 5 months)

Wolf's Fine Arts Auctioneers

Director of Marketing and Administration

January 1996 - May 2001 (5 years 5 months)

Rachel Davis Fine Arts

Gallery Manager

October 1992 - October 1995 (3 years 1 month)

Wolf's Fine Arts Auctioneers

Development and Administration

October 1989 - September 1992 (3 years)

---

## Education

Baldwin-Wallace College

Bachelor of Arts, Political Science · (1984 - 1989)

Reppert School of Auctioneering

Auctioneer Certificate · (1997 - 1997)



Feb. 12th 2021	Cuyahoga Arts & Culture (CAC)	Charna Sherman	Beachwood
Sept. 23 2021	Cuyahoga Arts & Culture (CAC)	Tanya Kaiser	Rocky River
Nov. 3rd 2021	Cuyahoga Arts & Culture (CAC)	Karolyn Isenhardt	Lakewood
March 19th 2019	Cuyahoga Arts & Culture (CAC)	Nancy Mendez	Cleveland
Aug. 11th 2020	Cuyahoga Arts & Culture (CAC)	Jenita McGowan	Cleveland Heights
June 4th 2021	Cuyahoga Arts & Culture (CAC)	Omar Kurdi	Strongsville

# County Council of Cuyahoga County, Ohio

## Resolution No. R2021-0252

<p>Sponsored by: <b>County Executive Budish/Department of Public Works</b></p>	<p><b>A Resolution</b> authorizing an amendment to revenue generating Agreement No. 50 with City of Cleveland to lease space in the City of Cleveland Police Department Headquarters, located at 1300 Ontario Street, Cleveland, for the period of 10/2/2018 – 10/1/2021 to exercise an option to extend the time period to 10/1/2022 and for a lease amount of \$16.00 per square foot per annum, plus parking fees and the cost of the City of Cleveland’s proportional share of utilities; authorizing the County Executive to execute the amendment and all other documents consistent with this Resolution; and declaring the necessity that this Resolution become immediately effective.</p>
--	---

WHEREAS, the County Executive/Department of Public Works/Division of County Engineer has recommended an amendment to a revenue generating agreement with City of Cleveland to lease space in the City of Cleveland Police Department Headquarters, located at 1300 Ontario Street, Cleveland, for the period of 10/2/2018 – 10/1/2021 to exercise an option to extend the time period to 10/1/2022 and for a lease amount of \$16.00 per square foot per annum, plus parking fees and the cost of the City of Cleveland’s proportional share of utilities; and

WHEREAS, this amendment increases the lease amount from \$14.00 to \$16.00 per square footage per annum and continues the number of parking spaces at 136 with square footage of 131,790.75; and

WHEREAS, the lease amendment will generate an estimated amount of \$2,108,652.00 per year base rent, \$171,360.00 per year in parking fees and the City of Cleveland’s proportional share of utilities; and

WHEREAS, it is necessary that this Resolution become immediately effective in order that critical services provided by Cuyahoga County can continue and to provide for the usual, daily operation of a County entity.

**NOW, THEREFORE, BE IT RESOLVED BY THE COUNTY COUNCIL OF CUYAHOGA COUNTY, OHIO:**

**SECTION 1.** That the Cuyahoga County Council hereby authorizes an amendment to a revenue generating agreement with City of Cleveland to lease space

in the City of Cleveland Police Department Headquarters, located at 1300 Ontario Street, Cleveland, for the period of 10/2/2018 – 10/1/2021 to exercise an option to extend the time period to 10/1/2022 and for a lease amount of \$16.00 per square foot per annum, plus parking fees and the cost of the City of Cleveland’s proportional share of utilities.

**SECTION 2.** That the County Executive is authorized to execute the amendment and all other documents consistent with this Resolution.

**SECTION 3.** It is necessary that this Resolution become immediately effective for the usual daily operation of the County; the preservation of public peace, health, or safety in the County; and any additional reasons set forth in the preamble. Provided that this Resolution receives the affirmative vote of at least eight members of Council, it shall take effect and be in force immediately upon the earliest occurrence of any of the following: (1) its approval by the County Executive through signature, (2) the expiration of the time during which it may be disapproved by the County Executive under Section 3.10(6) of the Cuyahoga County Charter, or (3) its passage by at least eight members of Council after disapproval pursuant to Section 3.10(7) of the Cuyahoga County Charter. Otherwise, it shall take effect and be in force from and after the earliest period allowed by law.

**SECTION 4.** It is found and determined that all formal actions of this Council relating to the adoption of this Resolution were adopted in an open meeting of the Council, and that all deliberations of this Council and of any of its committees that resulted in such formal action were in meetings open to the public, in compliance with all legal requirements, including Section 121.22 of the Ohio Revised Code.

On a motion by \_\_\_\_\_, seconded by \_\_\_\_\_, the foregoing Resolution was duly adopted.

Yeas:

Nays:

\_\_\_\_\_  
County Council President

\_\_\_\_\_  
Date

\_\_\_\_\_  
County Executive

\_\_\_\_\_  
Date

\_\_\_\_\_  
Clerk of Council

\_\_\_\_\_  
Date

First Reading/Referred to Committee:  
Committee(s) Assigned:

Journal \_\_\_\_\_  
\_\_\_\_\_, 20\_\_

2021 DPW, Third Amendment to Lease Agreement with City of Cleveland Police Headquarters Bldg; revenue generating

Department of Public Works is seeking authorization for a third amendment to a lease agreement with the City of Cleveland to lease space for the City of Cleveland Police Department at 1300 Ontario Street, Cleveland, Ohio for the original period 10/2/2018 – 10/1/2019 (R2017-0103) with the first amendment extending the lease to 10/1/2020(R2020-0010) and a second amendment extending the Term to 10/1/2021(R2020-0263) to exercise an option to extend the time period to 10/1/2022 for a lease amount of \$16.00 per square foot per annum, plus parking fees and costs of the City of Cleveland’s proportional share of utilities

Pursuant to Resolution R2017-0103 adopted by County Council on September 26, 2017, the County entered into a revenue generating lease agreement with the City of Cleveland for the County-owned building located at 1300 Ontario Street, Cleveland, Ohio, to lease certain space for the Cleveland Police Headquarters for the period 10/2/2018 to 10/1/2019 for a lease amount of \$10.00 per square foot per annum, plus parking fees for 143 spaces and the City’s proportional share of utilities.

The City exercised its option to renew the lease pursuant a letter dated August 12, 2019 (R2020-0010). This lease amendment increases the lease amount from \$10.00 to \$12.00 per square footage per annum, reduces the number of parking spaces from 143 to 136 and, starting March 2, 2020, reduces the square footage from 140,478.75 to 131,790.75. Pursuant to a second renewal the City extended its Term through 10/01/2021(R2020-0263).

The City wishes to exercise its third one (1) year Renewal Term. This third lease amendment increases the lease amount from \$14.00 to \$16.00 per square foot per annum and continues the number of parking spaces at 136 with square footage of 131,790.75.

From October 2, 2021 to October 1, 2022 the City shall pay the County the annual Base Rent of \$2,108,652.00 paid in monthly installments of \$175,721.00

During the term of the Third Renewal Term the City will pay the County \$171,360.00 per year in parking fees and the City of Cleveland’s proportional share of utilities. The number of parking spaces is 136 spaces @ \$105.00 each space which equals \$14,280.00/month.

Contractor and Project Information  
City of Cleveland-Division of Real Estate  
601 Lakeside Ave., Room 518  
Cleveland, Ohio 44114  
James DeRosa

Project Status & Planning  
This is the 3<sup>rd</sup> Amendment renewal to the Lease with the City of Cleveland

Funding  
This is an amendment to a revenue generating lease agreement – NO funds to be encumbered  
Base rent (CT571000-0925) now PW750100-42310  
Parking Fees (CT571125-0809) now PW705100-42120

## Office of Procurement and Diversity – Required Documents Checklist

Upload as “word” document in OnBase Document Management

Infor/Lawson RQ#:	N/A- Cleveland Police Headquarters Building Lease & renewal 1 <sup>st</sup> Amendment
Buyspeed RQ# (if applicable):	N/A
Infor/Lawson PO# Code (if applicable):	N/A
CM Contract#	50

	<b>Department</b>	<b>Clerk of the Board</b>
Briefing Memo	AMS	

Late Submittal Required:	Yes <input type="checkbox"/>	No <input type="checkbox"/>
Why is the amendment being submitted late?		
What is being done to prevent this from reoccurring?		

TAC Required:	Yes <input type="checkbox"/>	No <input checked="" type="checkbox"/>
---------------	------------------------------	--

Contract Amendments						Department initials	OPD
Justification Form						AMS	
IG#	12-0848					AMS	
Annual Non-Competitive Bid Contract Statement	Date:					N/A per law email	
Debarment/Suspension Verified	Date:	10/6/2020				AMS	
Auditor’s Finding	Date:	10/8/2020				AMS	
Vendor’s Submission							
W-9 – if required	Tax ID#	34-6000646	Date:			Revenue generating	
Independent Contractor (I.C.) Requirement			Date:			N/A per law email	
Amendment and Exhibits						AMS	
Cover - Master amendments only							
Contract Evaluation						AMS	
Matrix Law Screen shot (documenting approval of Contract Amendment; COI; Workers’ Compensation Certificate; Bid Guaranty and Contract Bond)						AMS	
COI - <i>*To be reviewed by the Department of Law. *OPD Buyer to check for attachment; not for compliance.</i>						N/A per law email	
Workers’ Compensation Insurance - <i>*To be reviewed by the Department of Law. *OPD Buyer to check for attachment; not for compliance.</i>						N/A per law email	
Original Executed Contract (containing insurance terms) AND any and all executed amendments to the contract - <i>*To be reviewed by the Department of Law.</i>						AMS	
Checklist Verification						AMS	

Other documentation may be required depending upon your specific item

Glossary of Terms at: <https://intranet.cuyahoga.cc/policies-procedures/procurement-information>

## Office of Procurement and Diversity – Required Documents Checklist

Upload as “word” document in OnBase Document Management

### Accounting Units – Revenue generating- no funds to be encumbered

Time Period	Accounting Unit	Account Number	Sub Account	Dollar Amount
10/2/2018-10/1/2019 (base rent)	PW750100	42310		\$1,404,787.75
(parking)- Original contract	PW705100	42120		\$171,360
10/2/2019-10/1/2020 (base rent)	PW750100	42310		\$1,624,929
(parking)- 1 <sup>st</sup> Amendment	PW705100	42120		\$180,180
			<b>TOTAL</b>	<b>\$3,381,256.75</b>

**PLEASE NOTE: Proportional Utility share information is not included and so these revenue numbers will NOT match what is deposited into the INFOR system**

<b>Current Contract History</b> CE/AG# (if applicable)	No contract # or RQ #
<b>Infor/Lawson PO# Code</b> (if applicable)	N/A
<b>BuySpeed or Lawson RQ#</b> (if applicable)	N/A
<b>CM Contract#</b>	50

### This is a REVENUE GENERATING LEASE- no funds to be encumbered

	Original Amount	Amendment Amount	Original Time Period/Amended End Date	Approval Date	Approval #
<b>Original Amount</b>	\$1,584,967.75			9/26/2017	R2017-0103
<b>Prior Amendment Amounts</b> (list separately)		\$1,796,289		1/29/2020	R2020-0010
		\$			
		\$			
<b>Pending Amendment</b>		\$			
<b>Total Amendments</b>		\$			
<b>Total Contact Amount</b>		\$3,381,256.75			

### OPD Use Only:

Prior Resolutions:	
Amend:	
Vendor Name:	
ftp:	
Amount:	
History/CE:	
EL:	
Procurement	

2 | Page

Revised 9/17/2020

# Office of Procurement and Diversity – Required Documents Checklist

Upload as “word” document in OnBase Document Management

Notes:	
--------	--

OPD Buyer approval:



## CONTRACT EVALUATION FORM

<b>Contractor</b>	City of Cleveland is lease tenant				
<b>Current Contract History: CE/AG# (if applicable) Infor/Lawson PO#:</b>	N/A- This is a revenue generating Lease for the Cleveland Police Headquarters Building				
<b>RQ#</b>	N/A				
<b>Time Period of Original Contract</b>	10/2/2018-10/1/2019 per R2017-0103				
<b>Background Statement</b>	Pursuant to R2017-0103, the County entered into a revenue generating lease agreement with the City of Cleveland to lease certain space for the Cleveland Police Headquarters at 1300 Ontario Street for the period of 10/2/2018 to 10/1/2019 for a lease amount of \$10 per square foot per annum, plus parking fees for 143 spaces and the City's proportional share of utilities. The First Amendment lease renewal (R2020-0010) extends the lease term to 10/2/2020 at \$12 per sq ft per annum with 136 parking spaces.				
<b>Service Description</b>	This Second Amendment to the Lease increases the lease amount to \$14 per sq ft per annum and includes 136 parking spaces with a total square footage of 131,790.75.				
<b>Performance Indicators</b>	This is a revenue generating lease agreement for the County.				
<b>Actual Performance versus performance indicators (include statistics):</b>	This is a revenue generating lease agreement for the County.				
<b>Rating of Overall Performance of Contractor</b>	<b>Superior</b>	<b>Above Average</b>	<b>Average</b>	<b>Below Average</b>	<b>Poor</b>
<b>Select One (X)</b>		X			
<b>Justification of Rating</b>	This is a revenue generating lease agreement for the County.				
<b>Department Contact</b>	Adrienne Simons				
<b>User Department</b>	Public Works				
<b>Date</b>	10/16/2020				

# County Council of Cuyahoga County, Ohio

## Resolution No. R2021-0253

Sponsored by: <b>County Executive Budish/Department of Public Works</b>	<b>A Resolution</b> authorizing an amendment to revenue generating Agreement No. 1864 with The Huntington National Bank, the successor in interest of FirstMerit Corporation, for the sale of naming rights for the Cleveland Convention Center for the period 11/1/2015 - 10/31/2035, to extend the time period to 10/31/2036; authorizing the County Executive to execute the amendment and all other documents consistent with this Resolution; and declaring the necessity that this Resolution become immediately effective.
---	---

WHEREAS, the County Executive/Department of Public Works has recommended an amendment to revenue generating Agreement No. 1864 with The Huntington National Bank, the successor in interest of FirstMerit Corporation, for the sale of naming rights for the Cleveland Convention Center for the period 11/1/2015 - 10/31/2035, to extend the time period to 10/31/2036; and

WHEREAS, the County and FirstMerit Corporation entered into a naming rights agreement effective November 1<sup>st</sup>, 2015, to provide FirstMerit Corporation with an exclusive license to name the County's Convention Center located at 300 Lakeside Avenue East, Cleveland, Ohio 44114; and

WHEREAS, FirstMerit Corporation assigned, sold, conveyed, and transferred to The Huntington National Bank, all of FirstMerit Corporation's rights, title, and interest and obligations arising under or in connection with the naming rights agreement on or about March 3, 2016; and

WHEREAS, the primary goal of this project is to extend the term of the contract by one year; and

WHEREAS, it is necessary that this Resolution become immediately effective in order that critical services provided by Cuyahoga County can continue and to provide for the usual, daily operation of a County entity.

**NOW, THEREFORE, BE IT RESOLVED BY THE COUNTY COUNCIL OF CUYAHOGA COUNTY, OHIO:**

**SECTION 1.** That the Cuyahoga County Council hereby authorizes an amendment to revenue generating Agreement No. 1864 with The Huntington National Bank, the successor in interest of FirstMerit Corporation, for the sale of naming rights for the Cleveland Convention Center for the period 11/1/2015 - 10/31/2035, to extend the time period to 10/31/2036.

**SECTION 2.** That the County Executive is authorized to execute the amendment and all other documents consistent with this Resolution.

**SECTION 3.** It is necessary that this Resolution become immediately effective for the usual daily operation of the County; the preservation of public peace, health, or safety in the County, and any additional reasons set forth in the preamble. Provided that this Ordinance receives the affirmative vote of at least eight members of Council, it shall take effect and be in force immediately upon the earliest occurrence of any of the following: (1) its approval by the County Executive through signature, (2) the expiration of the time during which it may be disapproved by the County Executive under Section 3.10(6) of the Cuyahoga County Charter, or (3) its passage by at least eight members of Council after disapproval pursuant to Section 3.10(7) of the Cuyahoga County Charter. Otherwise, it shall take effect and be in force from and after the earliest period allowed by law.

**SECTION 4.** It is found and determined that all formal actions of this Council relating to the adoption of this Resolution were adopted in an open meeting of the Council, and that all deliberations of this Council and of any of its committees that resulted in such formal action were in meetings open to the public, in compliance with all legal requirements, including Section 121.22 of the Ohio Revised Code.

On a motion by \_\_\_\_\_, seconded by \_\_\_\_\_, the foregoing Resolution was duly adopted.

Yeas:

Nays:

\_\_\_\_\_  
County Council President

\_\_\_\_\_  
Date

\_\_\_\_\_  
County Executive

\_\_\_\_\_  
Date

\_\_\_\_\_  
Clerk of Council

\_\_\_\_\_  
Date

First Reading/Referred to Committee:  
Committee(s) Assigned:

Journal \_\_\_\_\_  
\_\_\_\_\_, 20\_\_\_\_



Title: Department of Public Works requesting an amendment to a revenue generating agreement with The Huntington National Bank for the naming rights for the Cleveland Convention Center to extend the term from 11/1/2015 - 10/31/2035 to 10/31/2036

#### Scope of Work Summary

Public Works is requesting approval of an amendment to a revenue generating agreement with The Huntington National Bank.

The County and FirstMerit Corporation entered into a Naming Rights Agreement to provide FirstMerit Corporation with an exclusive license to name the County's Convention Center located at 300 Lakeside Avenue East, Cleveland, Ohio 44114, for the period 11/1/2015 – 10/31/2035 and for the amount of \$10,321,344.00.

On 3/3/ 2016 FirstMerit Corporation assigned, sold, conveyed, and transferred to The Huntington National Bank, all of FirstMerit Corporation's rights, title, and interest and obligations arising under or in connection with the Naming Rights Agreement.

The primary goal of the project is to extend the term of the contract by one (1) year. The initial term was November 1, 2015 – October 31, 2035 and will change to November 1, 2015 – October 31, 2036.

There is no change in the dollar amount.

#### Procurement

The total value of this Revenue Generating Contract is \$10,321,344.00.for the sale of naming rights for the Cleveland Conventions Center.

#### Contractor and Project Information

The address(es) of all vendors and/or contractors is:

The Huntington National Bank

41 South High Street, HC0910

Columbus, Ohio 43215

Sean P. Richardion/Regional President

#### Project Status and Planning

The project occurs one time.

#### Funding

The project is a Revenue Generating Contract

The schedule of payments are received annually.

## Office of Procurement and Diversity – Required Documents Checklist

Upload as “word” document in OnBase Document Management

Infor/Lawson RQ#:	
BuySpeed RQ# (if applicable):	
Infor/Lawson PO# Code (if applicable):	
CM Contract#	CM1864

	<b>Department</b>	<b>Clerk of the Board</b>
Briefing Memo – See note - OK	tw	

Late Submittal Required:	Yes <input type="checkbox"/>	No <input checked="" type="checkbox"/>
Why is the amendment being submitted late?		
What is being done to prevent this from reoccurring?		

TAC Required:	Yes <input type="checkbox"/>	No <input checked="" type="checkbox"/>
---------------	------------------------------	--

Contract Amendments					
				Department initials	OPD
Justification Form 4.13.21				tw	See note - OK
IG#	12.1512 REG 12.31.21 <b>Huntington Bank 12-1512-REG 31DEC2021</b>			tw	OK
Annual Non-Competitive Bid Contract Statement	Date:	n/a-Revenue Generating Contract Amendment		tw	N/A
Debarment/Suspension Verified	Date:	9.14.21		tw	
Auditor's Finding	Date:	9.8.21		tw	
Vendor's Submission					Signed amendment OK
W-9 – if required	Tax ID#	Date:			N/A
Independent Contractor (I.C.) Requirement	Date:	n/a-Revenue Generating Contract Amendment		tw	N/A
Amendment and Exhibits				tw	OK
Cover - Master amendments only					
Contract Evaluation n/a				tw	N/A
Matrix Law Screen shot (documenting approval of Contract Amendment; COI; Workers' Compensation Certificate; Bid Guaranty and Contract Bond PWD-557				Tw - n/a but reference in legal documents	
COI - <i>*To be reviewed by the Department of Law. PWD-2470</i> <i>*OPD Buyer to check for attachment; not for compliance.</i>				tw	
Workers' Compensation Insurance - <i>*To be reviewed by the Department of Law.</i>					

## Office of Procurement and Diversity – Required Documents Checklist

Upload as “word” document in OnBase Document Management

<b>*OPD Buyer to check for attachment; not for compliance.</b>			
Original Executed Contract ( <i>containing insurance terms</i> ) <b>AND</b> any and all executed amendments to the contract - <b>*To be reviewed by the Department of Law.</b>			
Checklist Verification	10.4.21	tw	

Other documentation may be required depending upon your specific item

Glossary of Terms at: <https://intranet.cuyahoga.cc/policies-procedures/procurement-information>

### Accounting Units

Time Period	Accounting Unit	Account Number	Sub Account	Dollar Amount
11.1.2035 – 10.31.2036				<b>\$0.00</b>
			<b>TOTAL</b>	<b>\$0.00</b>

<b>Current Contract History</b> CE/AG# (if applicable)	
<b>Infor/Lawson PO# Code</b> (if applicable)	
<b>BuySpeed or Lawson RQ#</b> (if applicable)	
<b>CM Contract#</b>	

	Original Amount	Amendment Amount	Original Time Period/Amended End Date	Approval Date	Approval #
<b>Original Amount</b>	<b>\$10,321,344.00</b>	<b>0.00</b>	11-1-2015 to 10/31/2035	10.27.2015	R2015-0200
<b>Prior Amendment Amounts</b> (list separately)		<b>\$0.00</b>	11-1-2035 to 10/31/2036		
		\$			
		\$			
<b>Pending Amendment</b>		\$			
<b>Total Amendments</b>		\$			
<b>Total Contact Amount</b>	<b>\$10,321,344.00</b>	<b>\$0.00</b>			



## Office of Procurement and Diversity – Required Documents Checklist

Upload as “word” document in OnBase Document Management

### OPD Use Only:

Prior Resolutions:	R2015-0200 (original agreement with First Merit – Huntington assumed rights from First Merit)
Amend:	1864 Amendment 1
Vendor Name:	Huntington Bank
ftp:	November 1, 2015 – October 31, 2035 extending to October 31, 2036
Amount:	\$0.00 (revenue generating)
History/CE:	N/A
EL:	OK
Procurement Notes:	<p>10.13.21: 1. Justification Form contains incorrect number in the first description.                  2. Line dates are incorrect, DP corrected.                  3. Briefing Memo contains incorrect total agreement amounts.                  4. Question tab: Correct Original End Date to 10/31/2035.                  TW to upload corrected documents and make the changes. Once completed DP buyer will finalize review and approve.                  AHW 10.13.21                  Corrections made; no cover attached to item as well as the accounting units not being completed as this is a Revenue Generating Agreement – ok to approve</p>

OPD Buyer approval: **ok to approve after discussion with CT; AHW 10.13.21**

# County Council of Cuyahoga County, Ohio

## Resolution No. R2021-0254

Sponsored by: <b>County Executive Budish/Department of Public Works/Division of County Engineer</b>	<b>A Resolution</b> approving Right-of-Way Exhibits as set forth in Plat No. M-5051 for reconstruction of Stearns Road from Schady Road to Bagley Road in Olmsted Township; authorizing the County Executive through the Department of Public Works to acquire said necessary Rights-of-Way; and declaring the necessity that this Resolution become immediately effective.
---	---

WHEREAS, the County Executive/Department of Public Works/Division of County Engineer has recommended approving Right-of-Way Exhibits as set forth in Plat No. M-5051 for reconstruction of Stearns Road from Schady Road to Bagley Road in Olmsted Township; and

WHEREAS, the primary goal of this project is to obtain Council’s review and approval of the right-of-way plans and approval of the required acquisitions needed for Plat No. M-5051 for reconstruction of Stearns Road from Schady Road to Bagley Road in Olmsted Township; and

WHEREAS, the project is located in Council District 5; and

WHEREAS, the estimated right-of-way acquisition cost is \$172,480.00, which will be funded 100% by County Road and Bridge Funds; and

WHEREAS, it is necessary that this Resolution become immediately effective in order that critical services provided by Cuyahoga County can continue and to provide for the usual, daily operation of a County entity.

**NOW, THEREFORE, BE IT RESOLVED BY THE COUNTY COUNCIL OF CUYAHOGA COUNTY, OHIO:**

**SECTION 1.** That the Cuyahoga County Council hereby approves Right-of-Way Exhibits as set forth in Plat No. M-5051 for reconstruction of Stearns Road from Schady Road to Bagley Road in Olmsted Township.

**SECTION 2.** That the County Executive through the Department of Public Works is hereby authorized to acquire the Right-of-Way necessary for said improvement.

**SECTION 3.** That all proceedings relative to the Right-of-Way Exhibit as set forth in Plat No. M-5051 are hereby ordered copied into the Road Record of the County by the Department of Public Works are copied into all other proper records of the County by the Fiscal Officer as required by law.

**SECTION 4.** It is necessary that this Resolution become immediately effective for the usual daily operation of the County; the preservation of public peace, health or safety in the County; and any additional reasons set forth in the preamble. Provided that this Resolution receives the affirmative vote of at least eight members of Council, it shall take effect and be in force immediately upon the earliest occurrence of any of the following: (1) its approval by the County Executive through signature, (2) the expiration of the time during which it may be disapproved by the County Executive under Section 3.10(6) of the Cuyahoga County Charter, or (3) its passage by at least eight members of Council after disapproval pursuant to Section 3.10(7) of the Cuyahoga County Charter. Otherwise, it shall take effect and be in force from and after the earliest period allowed by law.

**SECTION 5.** It is found and determined that all formal actions of this Council relating to the adoption of this Resolution were adopted in an open meeting of the Council, and that all deliberations of this Council and of any of its committees that resulted in such formal action were in meetings open to the public, in compliance with all legal requirements, including Section 121.22 of the Ohio Revised Code.

On a motion by \_\_\_\_\_, seconded by \_\_\_\_\_, the foregoing Resolution was duly adopted.

Yeas:

Nays:

\_\_\_\_\_  
County Council President

\_\_\_\_\_  
Date

\_\_\_\_\_  
County Executive

\_\_\_\_\_  
Date

\_\_\_\_\_  
Clerk of Council

\_\_\_\_\_  
Date

First Reading/Referred to Committee:  
Committee(s) Assigned:

Journal \_\_\_\_\_  
\_\_\_\_\_, 20\_\_

### Scope of Work Summary

The Department of Public Works is seeking the following in connection with reconstruction of Stearns Road (CR-76) between Schady Road to Bagley Road in Olmsted Township, Ohio: (1) approval of the Right-of-Way Exhibits and Legal Descriptions (2) authority to acquire required right-of-way; (3) allowing payment of the fair market value estimate ruling that special assessments are not to be levied and collected to pay any part of the County's costs of these improvements.

Since October 13, 2021 and continuing until the Resolution granting the requested action is either adopted or rejected, the Department of Public Works has posted and provided continuous notice of the following on its website:

- The Department of Public Works has submitted the Project's Exhibits and Legal Descriptions (M-5051) for County Council approval and that the same are available for viewing on said website;
- The Department of Public Works intends to acquire right-of-way for said improvement;
- That a First Reading of the Resolution approving the revised right-of-way plans will be made by the Cuyahoga County Council at its meeting scheduled to begin at 5:00 p.m. on November 9, 2021; and,
- That general public access and ability to review the right-of-way plans via an electronic link as indicated.

There are a total of 35 ownerships and 41 parcels associated with the acquisition of right-of-way for this project

- a. The primary goal of this project is to obtain Council's review and approval of the right-of-way plans and approval of the required acquisitions needed for the Stearns Road Project
- b. Location: Stearns Road (CR-76) between Schady Road to Bagley Road in Olmsted Township, Ohio
- c. District 5

### Project Status

Acquisition must be completed by July 2022. The Project is anticipated for construction in the beginning of 2023.

### Funding

Acquisition Cost Estimate: \$172,480

Construction Cost Estimate: \$4,576,430 (Road & Bridge: \$2,456,492 + Issue 1: \$2,119,938)

# M-5051 EXHIBIT "A"



SITUATED IN THE TOWNSHIP OF OLMSTED, COUNTY OF CUYAHOGA AND STATE OF OHIO AND KNOWN AS BEING PART OF ORIGINAL OLMSTED TOWNSHIP, LOT NO. 8, TRACT NO. 3

## PARCEL 1-T & 1-SH

TEMPORARY EASEMENT AND HIGHWAY EASEMENT FOR THE PURPOSE OF PERFORMING THE WORK NECESSARY TO MAKE ROADWAY IMPROVEMENTS

100+00.00  $\oslash$  STEARNS ROAD C.R. 76 =  
400+00.00 P.I.  $\oslash$  SCHADY ROAD

EX. C.C.E. ALUM. CAP  
IN MON. BOX

100+68.52  
0.00'  $\oslash$

$\oslash$  STEARNS ROAD C.R. 76 (60')

101+70.77  
0.00'  $\oslash$

133+43.17  
EX. 5/8" I.P.  
IN MON. BOX

3172.40'  
N00°08'00"E

90°43'59"  
OBS.

101+70.77  
30.00' RT.  
P.P.O.B. (1-T)

N89°24'01"E

$\oslash$  BAGLEY ROAD  
C.R. 27 (60')

### CURVE 1

- R = 40.00'
- A = 61.98'
- C = 55.96'
- T = 39.16'
- C.B. = N44°15'22"W
- $\Delta$  = 88°46'44"

100+28.53  
69.15' RT.

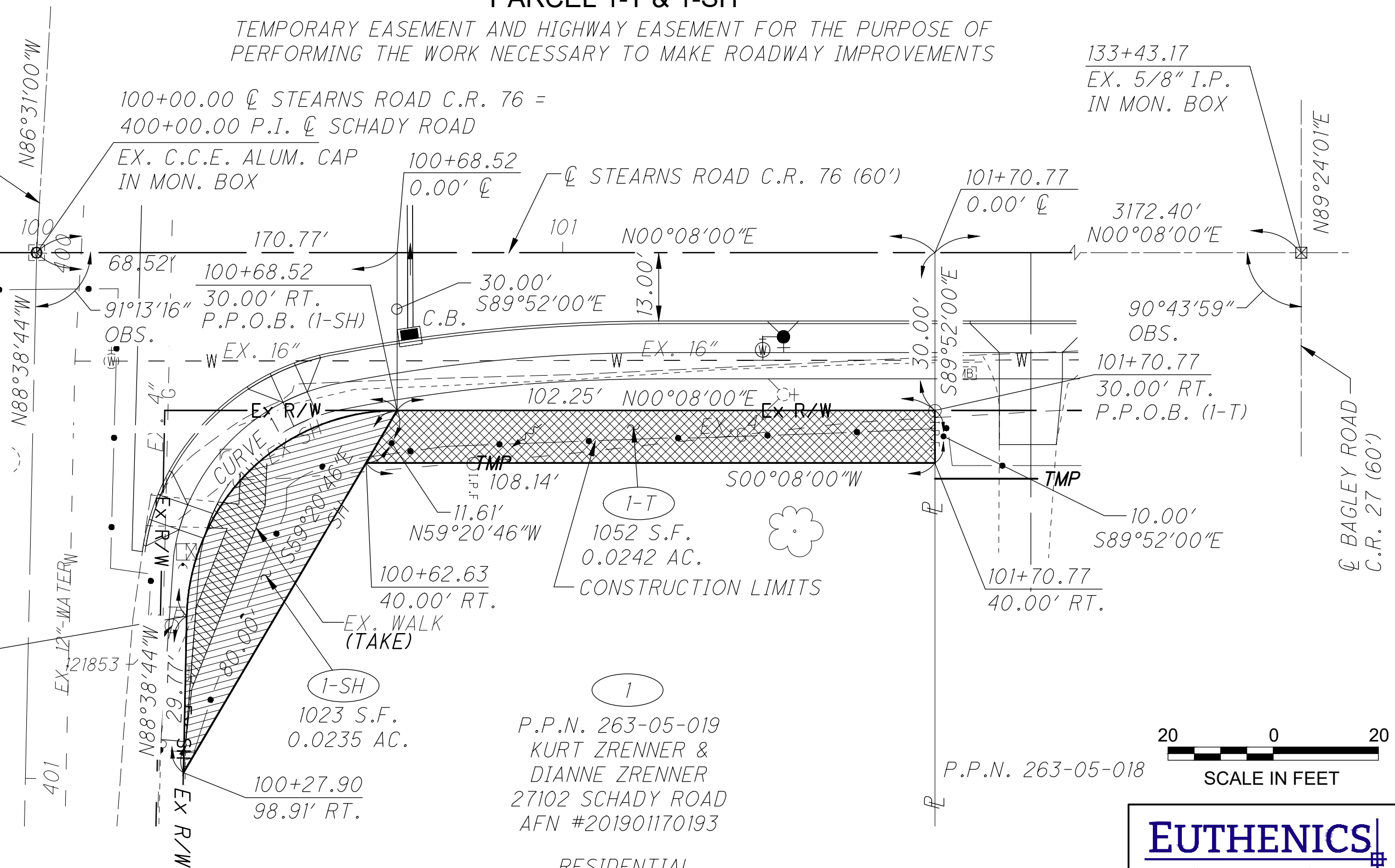

F:\Jobs\1163 - Cuy. Co. GEC - AECOM\01 - Stearns Road\Design\Row\Sheets\1163\_ Exhibits-East.dwg 28-Sep-21 10:32 AM

P.P.N. 263-05-019  
KURT ZRENNER &  
DIANNE ZRENNER  
27102 SCHADY ROAD  
AFN #201901170193

RESIDENTIAL

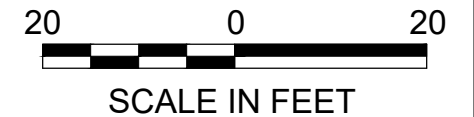

**EUTHENICS**  
8235 Mohawk Dr. | Cleveland, OH 44136

# M-5051 EXHIBIT "A"



SITUATED IN THE TOWNSHIP OF OLMSTED, COUNTY OF CUYAHOGA AND STATE OF OHIO AND KNOWN AS BEING PART OF ORIGINAL OLMSTED TOWNSHIP, LOT NO. 8, TRACT NO. 3

## PARCEL 3-T

TEMPORARY EASEMENT FOR THE PURPOSE OF PERFORMING THE WORK NECESSARY TO MAKE ROADWAY IMPROVEMENTS

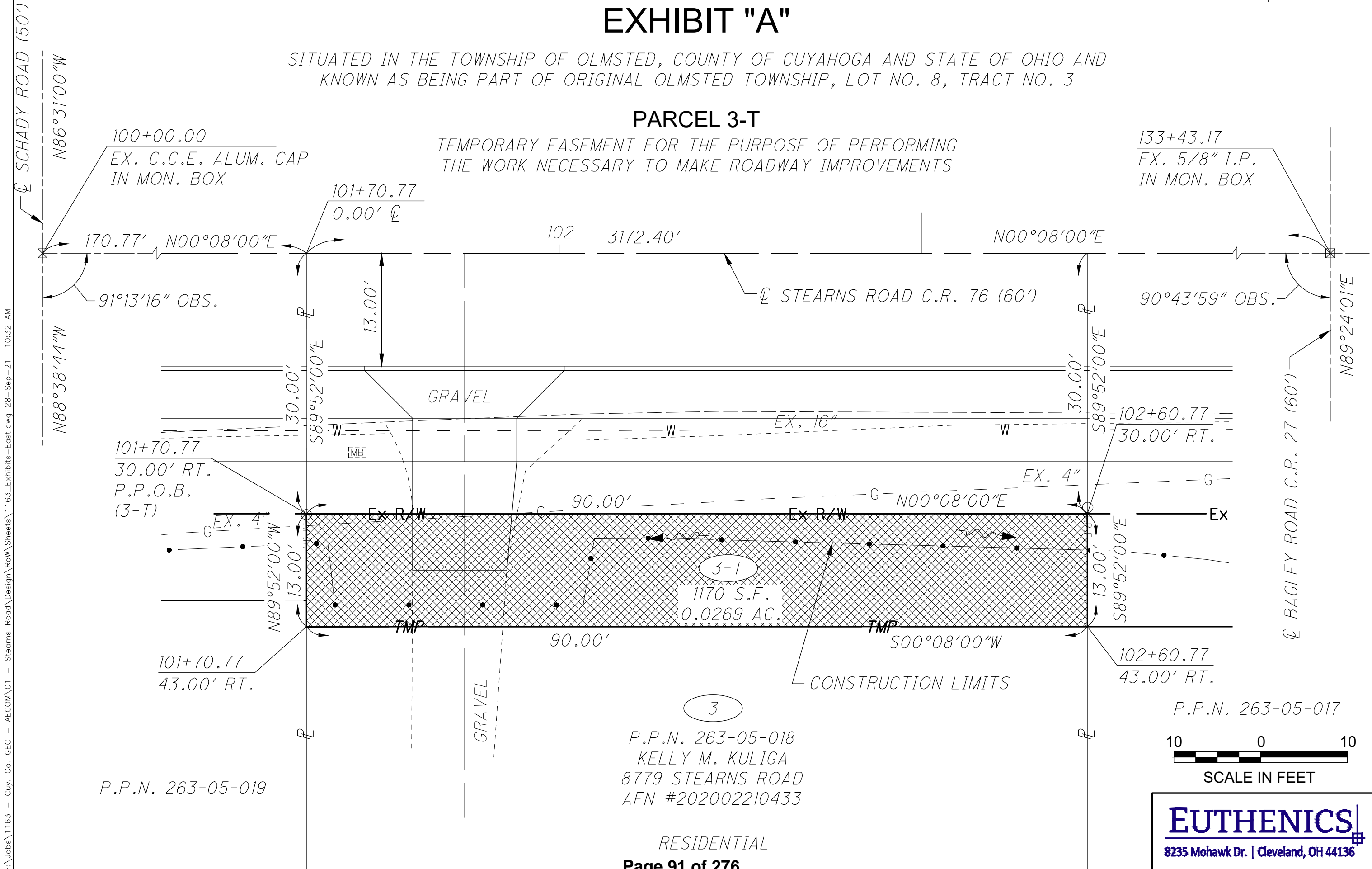

P.P.N. 263-05-019

P.P.N. 263-05-018  
KELLY M. KULIGA  
8779 STEARNS ROAD  
AFN #202002210433

RESIDENTIAL

P.P.N. 263-05-017



**EUTHENICS**  
8235 Mohawk Dr. | Cleveland, OH 44136

# M-5051 EXHIBIT "A"



SITUATED IN THE TOWNSHIP OF OLMSTED, COUNTY OF CUYAHOGA AND STATE OF OHIO AND KNOWN AS BEING PART OF ORIGINAL OLMSTED TOWNSHIP, LOT NO. 8, TRACT NO. 3

## PARCEL 5-T

TEMPORARY EASEMENT FOR THE PURPOSE OF PERFORMING THE WORK NECESSARY TO MAKE ROADWAY AND DRIVE IMPROVEMENTS

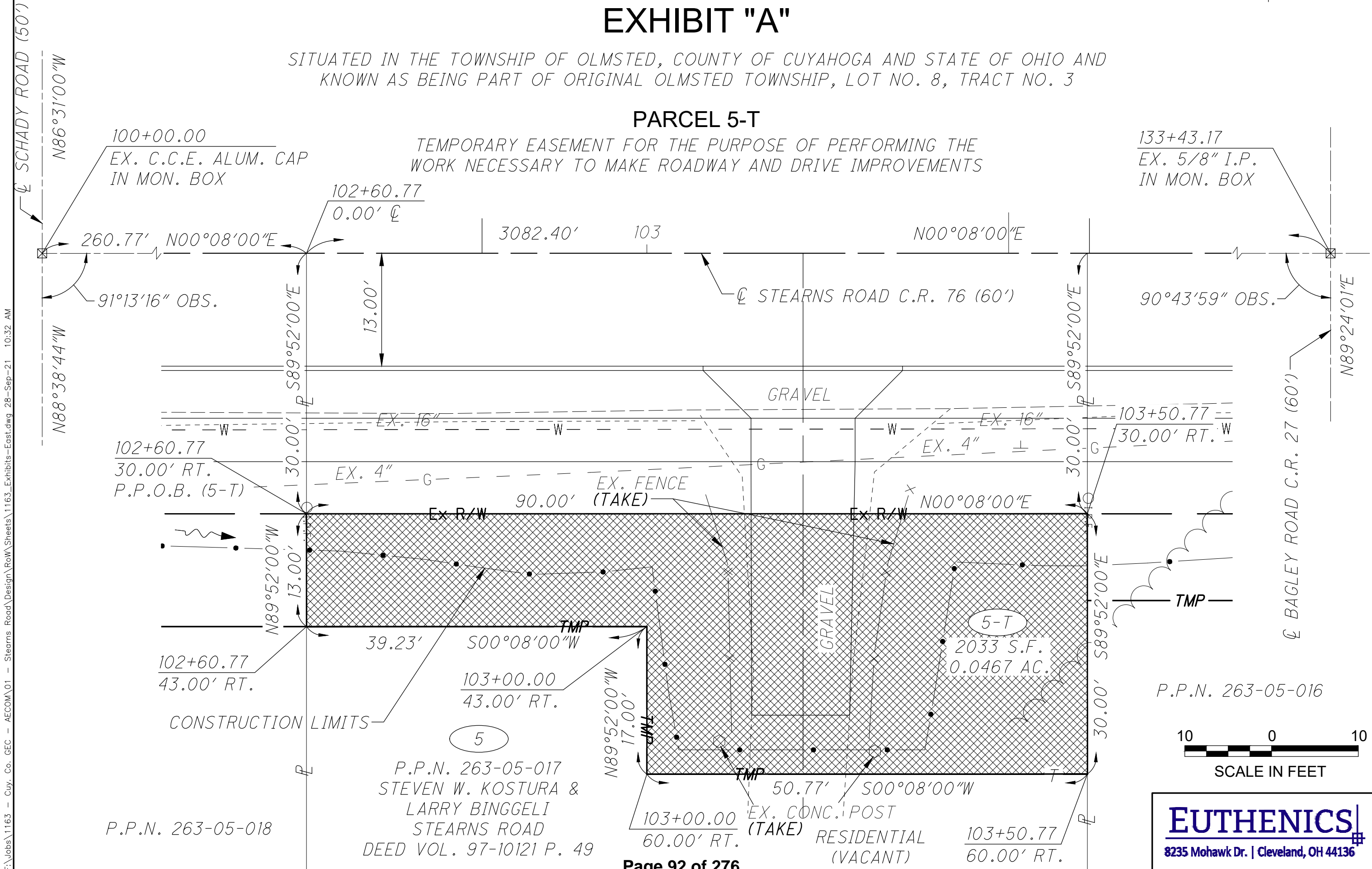

133+43.17  
EX. 5/8" I.P.  
IN MON. BOX

100+00.00  
EX. C.C.E. ALUM. CAP  
IN MON. BOX

102+60.77  
30.00' RT.  
P.P.O.B. (5-T)

102+60.77  
43.00' RT.

P.P.N. 263-05-018

P.P.N. 263-05-017  
STEVEN W. KOSTURA &  
LARRY BINGGELI  
STEARNS ROAD  
DEED VOL. 97-10121 P. 49

P.P.N. 263-05-016



**EUTHENICS**  
8235 Mohawk Dr. | Cleveland, OH 44136

F:\Jobs\1163 - Cuy. Co. GEC - AECOM\01 - Stearns Road\Design\Row\Sheets\1163\_Exhibits-East.dwg 28-Sep-21 10:32 AM



# M-5051 EXHIBIT "A"



SITUATED IN THE TOWNSHIP OF OLMSTED, COUNTY OF CUYAHOGA AND STATE OF OHIO AND KNOWN AS BEING PART OF ORIGINAL OLMSTED TOWNSHIP, LOT NO. 8, TRACT NO. 3

## PARCEL 7-T

TEMPORARY EASEMENT FOR THE PURPOSE OF PERFORMING THE WORK NECESSARY TO MAKE ROADWAY IMPROVEMENTS

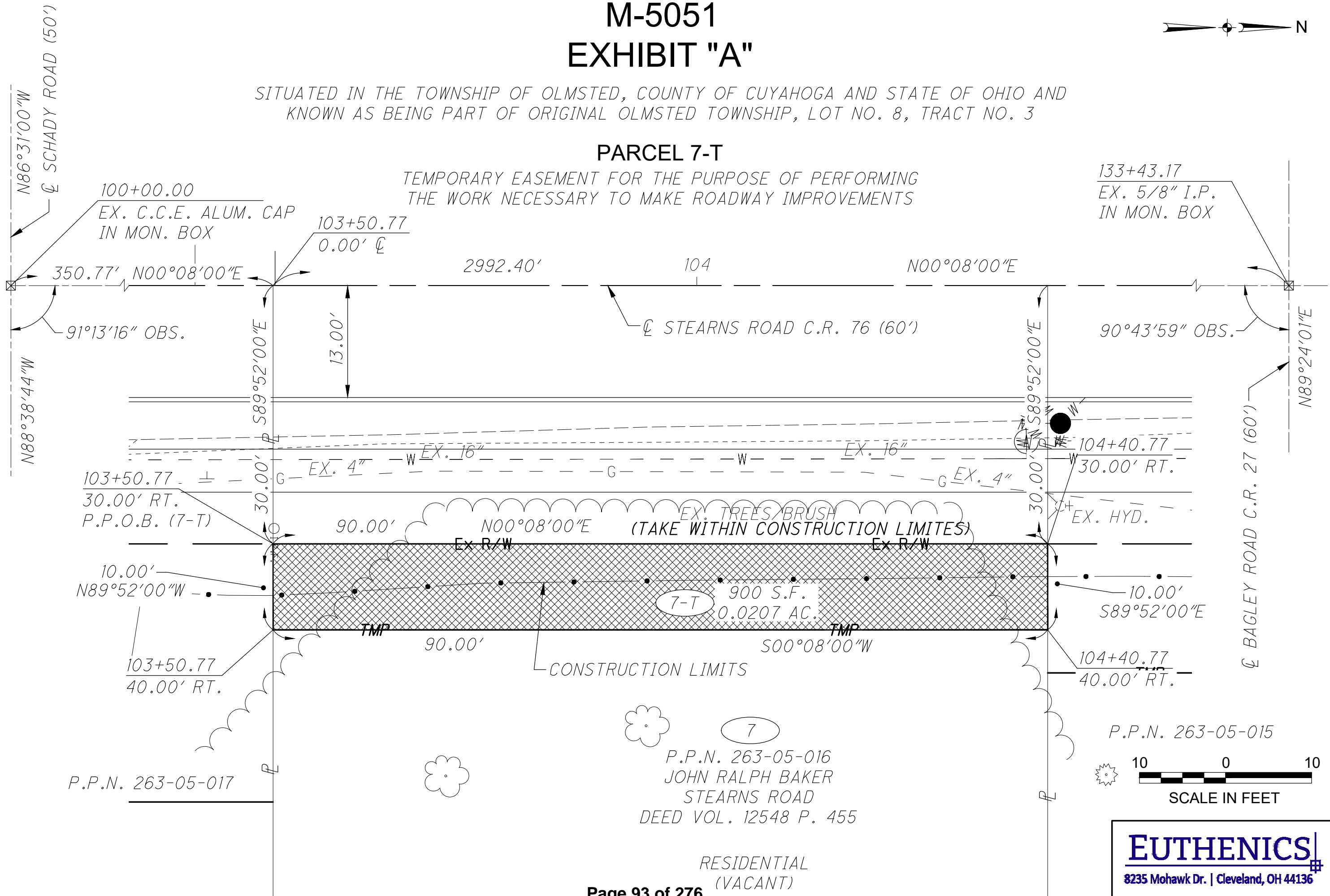

F:\Jobs\1163 - Cuy. Co. GEC - AECOM\01 - Stearns Road\Design\RoW\Sheets\1163\_Exhibits-East.dwg 28-Sep-21 10:32 AM

P.P.N. 263-05-017

7  
P.P.N. 263-05-016  
JOHN RALPH BAKER  
STEARNS ROAD  
DEED VOL. 12548 P. 455

RESIDENTIAL  
(VACANT)

P.P.N. 263-05-015

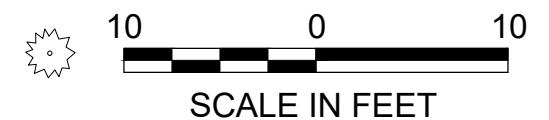

**EUTHENICS**  
8235 Mohawk Dr. | Cleveland, OH 44136

# M-5051 EXHIBIT "A"



SITUATED IN THE TOWNSHIP OF OLMSTED, COUNTY OF CUYAHOGA AND STATE OF OHIO AND KNOWN AS BEING PART OF ORIGINAL OLMSTED TOWNSHIP, LOT NO. 8, TRACT NO. 3

## PARCEL 8-T

TEMPORARY EASEMENT FOR THE PURPOSE OF PERFORMING THE WORK NECESSARY TO MAKE ROADWAY AND DRIVE IMPROVEMENTS

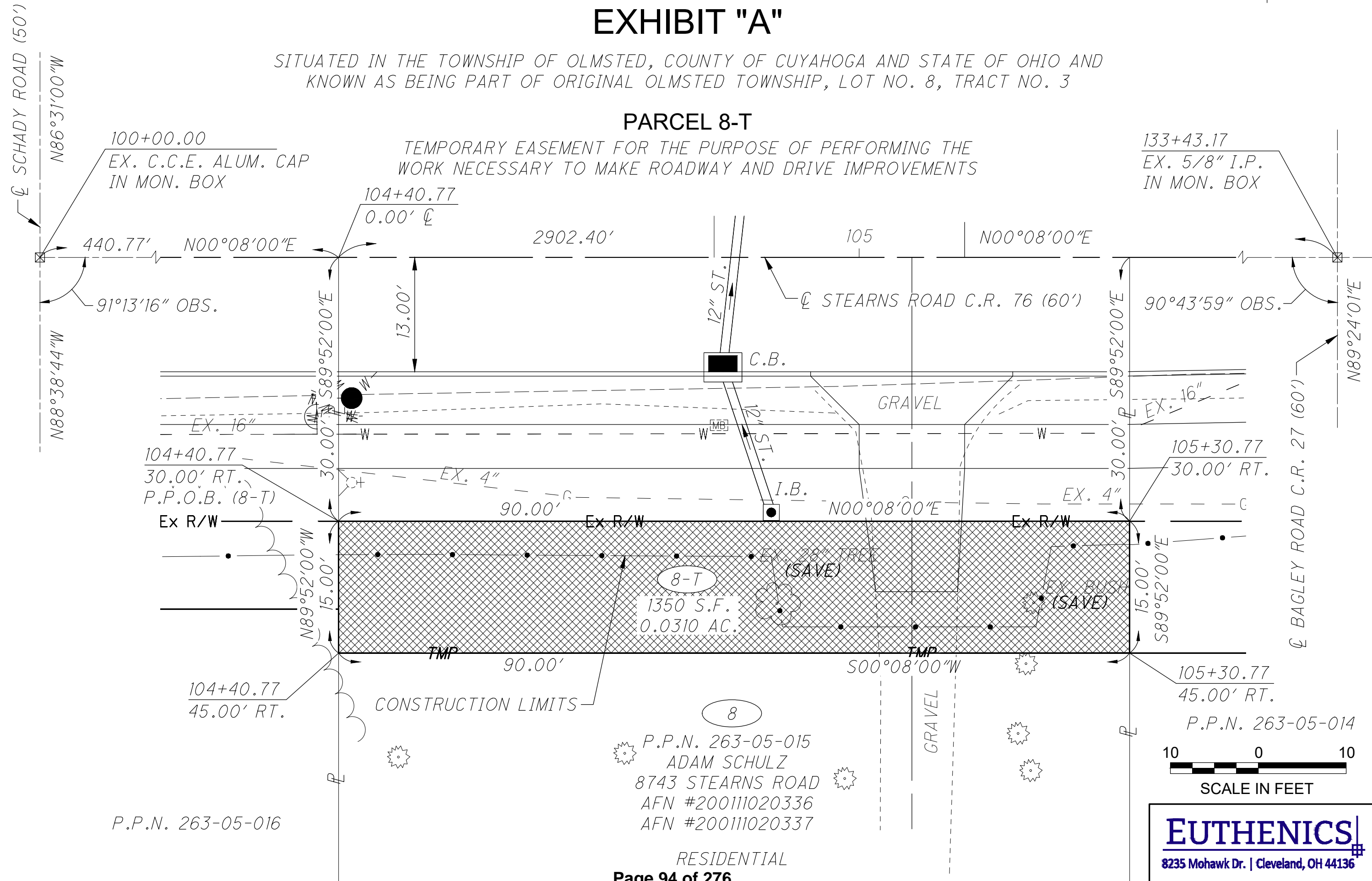

P.P.N. 263-05-016

8  
P.P.N. 263-05-015  
ADAM SCHULZ  
8743 STEARNS ROAD  
AFN #200111020336  
AFN #200111020337

RESIDENTIAL

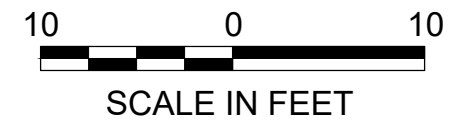

**EUTHENICS**  
8235 Mohawk Dr. | Cleveland, OH 44136

# M-5051 EXHIBIT "A"

SITUATED IN THE TOWNSHIP OF OLMSTED, COUNTY OF CUYAHOGA AND STATE OF OHIO AND KNOWN AS BEING PART OF ORIGINAL OLMSTED TOWNSHIP, LOT NO. 8, TRACT NO. 3



## PARCEL 9-T

TEMPORARY EASEMENT FOR THE PURPOSE OF PERFORMING THE WORK NECESSARY TO MAKE ROADWAY AND DRIVE IMPROVEMENTS

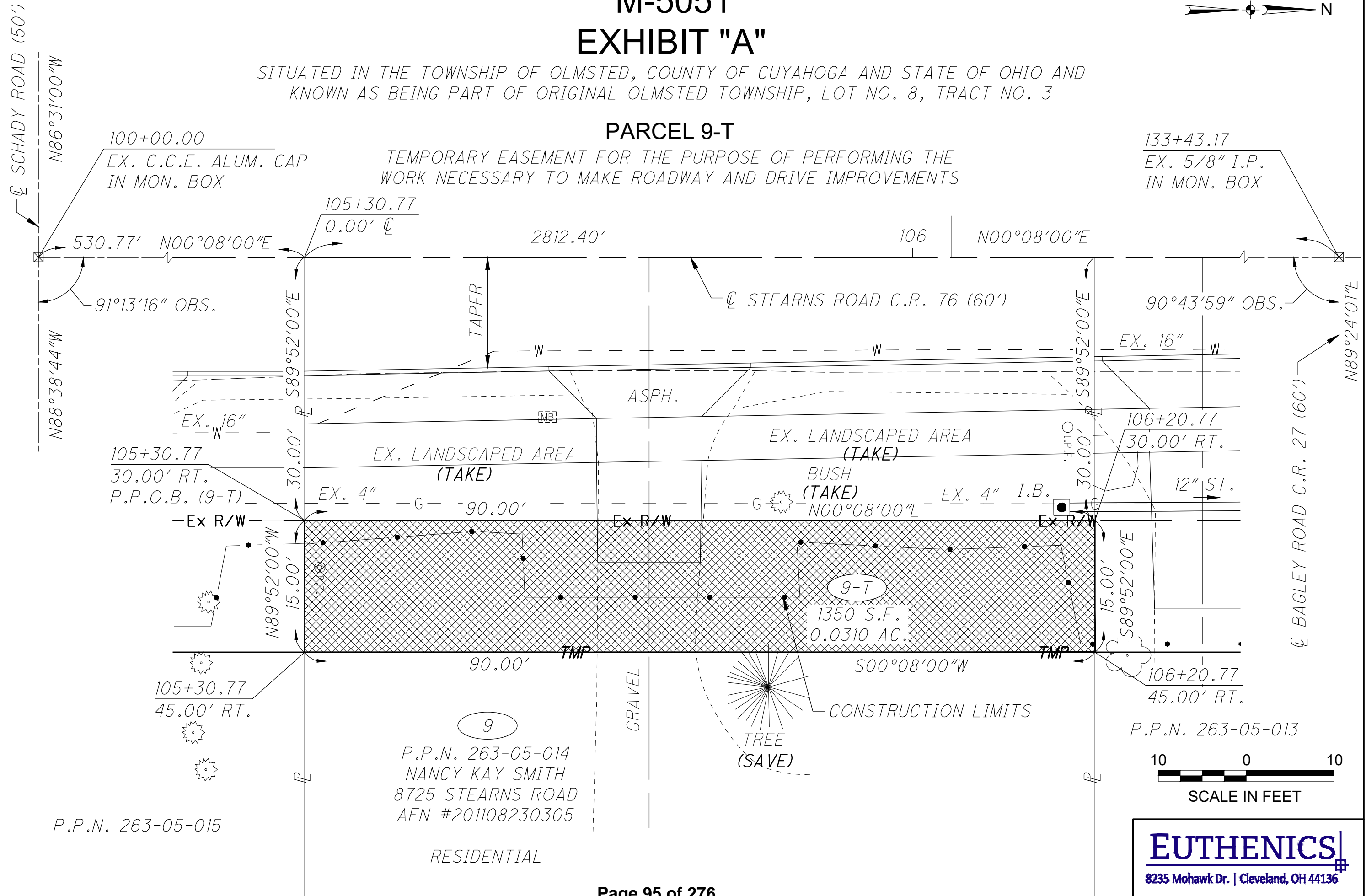

**EUTHENICS**  
8235 Mohawk Dr. | Cleveland, OH 44136

# M-5051 EXHIBIT "A"



SITUATED IN THE TOWNSHIP OF OLMSTED, COUNTY OF CUYAHOGA AND STATE OF OHIO AND KNOWN AS BEING PART OF ORIGINAL OLMSTED TOWNSHIP, LOT NO. 8, TRACT NO. 3

## PARCEL 10-T

TEMPORARY EASEMENT FOR THE PURPOSE OF PERFORMING THE WORK NECESSARY TO MAKE ROADWAY AND DRIVE IMPROVEMENTS

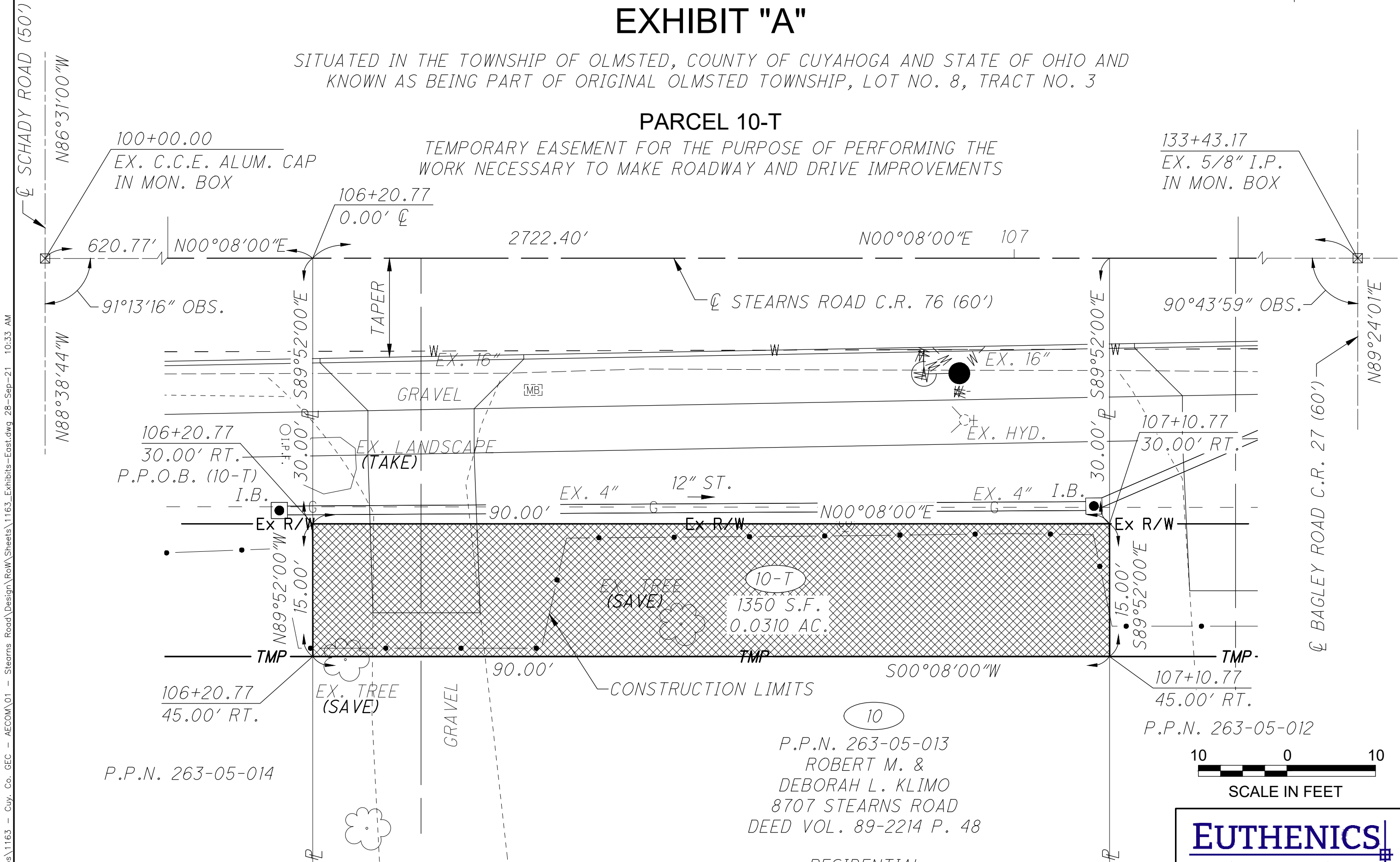

P.P.N. 263-05-014

10  
P.P.N. 263-05-013  
ROBERT M. &  
DEBORAH L. KLIMO  
8707 STEARNS ROAD  
DEED VOL. 89-2214 P. 48

RESIDENTIAL

P.P.N. 263-05-012

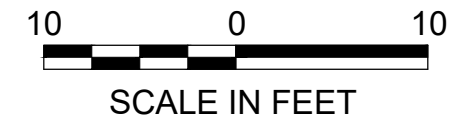

**EUTHENICS**  
8235 Mohawk Dr. | Cleveland, OH 44136





# M-5051 EXHIBIT "A"



SITUATED IN THE TOWNSHIP OF OLMSTED, COUNTY OF CUYAHOGA AND STATE OF OHIO AND KNOWN AS BEING PART OF ORIGINAL OLMSTED TOWNSHIP, LOT NO. 8, TRACT NO. 3

## PARCEL 12-T

TEMPORARY EASEMENT FOR THE PURPOSE OF PERFORMING THE WORK NECESSARY TO MAKE ROADWAY AND DRIVE IMPROVEMENTS

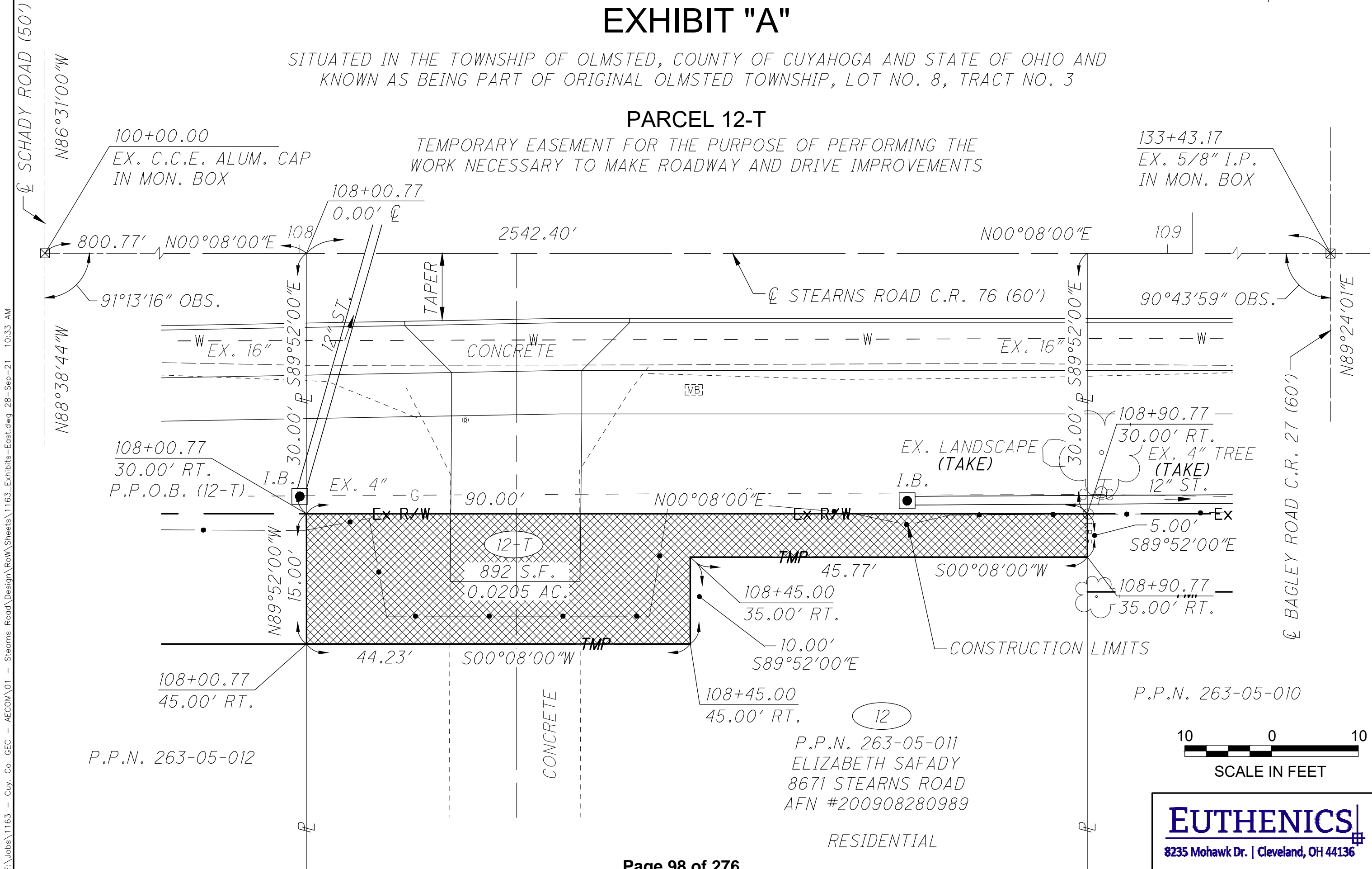

P.P.N. 263-05-012

P.P.N. 263-05-011  
ELIZABETH SAFADY  
8671 STEARNS ROAD  
AFN #200908280989

RESIDENTIAL

P.P.N. 263-05-010



**EUTHENICS**  
8235 Mohawk Dr. | Cleveland, OH 44136

F:\Jobs\1163 - Cuy. Co. GEC - AECOM\01 - Stearns Road\Design\RoW\Sheets\1163\_Exhibits-East.dwg 28-Sep-21 10:33 AM



# M-5051 EXHIBIT "A"



SITUATED IN THE TOWNSHIP OF OLMSTED, COUNTY OF CUYAHOGA AND STATE OF OHIO AND KNOWN AS BEING PART OF ORIGINAL OLMSTED TOWNSHIP, LOT NO. 8, TRACT NO. 3

## PARCEL 14-T

TEMPORARY EASEMENT FOR THE PURPOSE OF PERFORMING THE WORK NECESSARY TO MAKE ROADWAY AND DRIVE IMPROVEMENTS

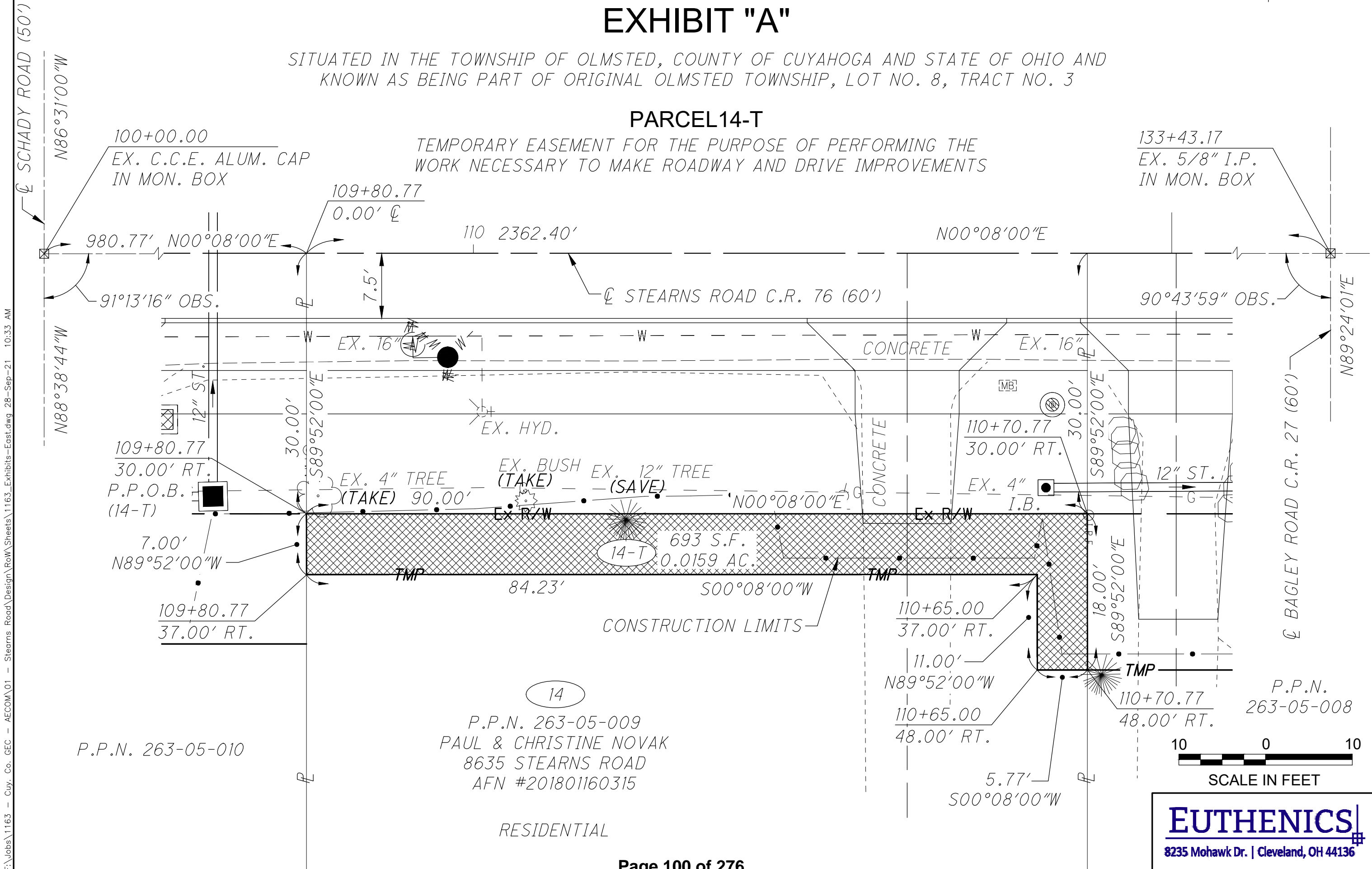

P.P.N. 263-05-010

14  
P.P.N. 263-05-009  
PAUL & CHRISTINE NOVAK  
8635 STEARNS ROAD  
AFN #201801160315

RESIDENTIAL

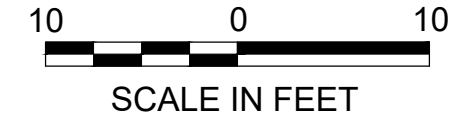

**EUTHENICS**  
8235 Mohawk Dr. | Cleveland, OH 44136

F:\Jobs\1163 - Cuy. Co. GEC - AECOM\01 - Stearns Road\Design\RoW\Sheets\1163\_Exhibits-East.dwg 28-Sep-21 10:33 AM



# M-5051 EXHIBIT "A"



SITUATED IN THE TOWNSHIP OF OLMSTED, COUNTY OF CUYAHOGA AND STATE OF OHIO AND KNOWN AS BEING PART OF ORIGINAL OLMSTED TOWNSHIP, LOT NO. 8, TRACT NO. 3

## PARCEL 15-T

TEMPORARY EASEMENT FOR THE PURPOSE OF PERFORMING THE WORK NECESSARY TO MAKE ROADWAY AND DRIVE IMPROVEMENTS

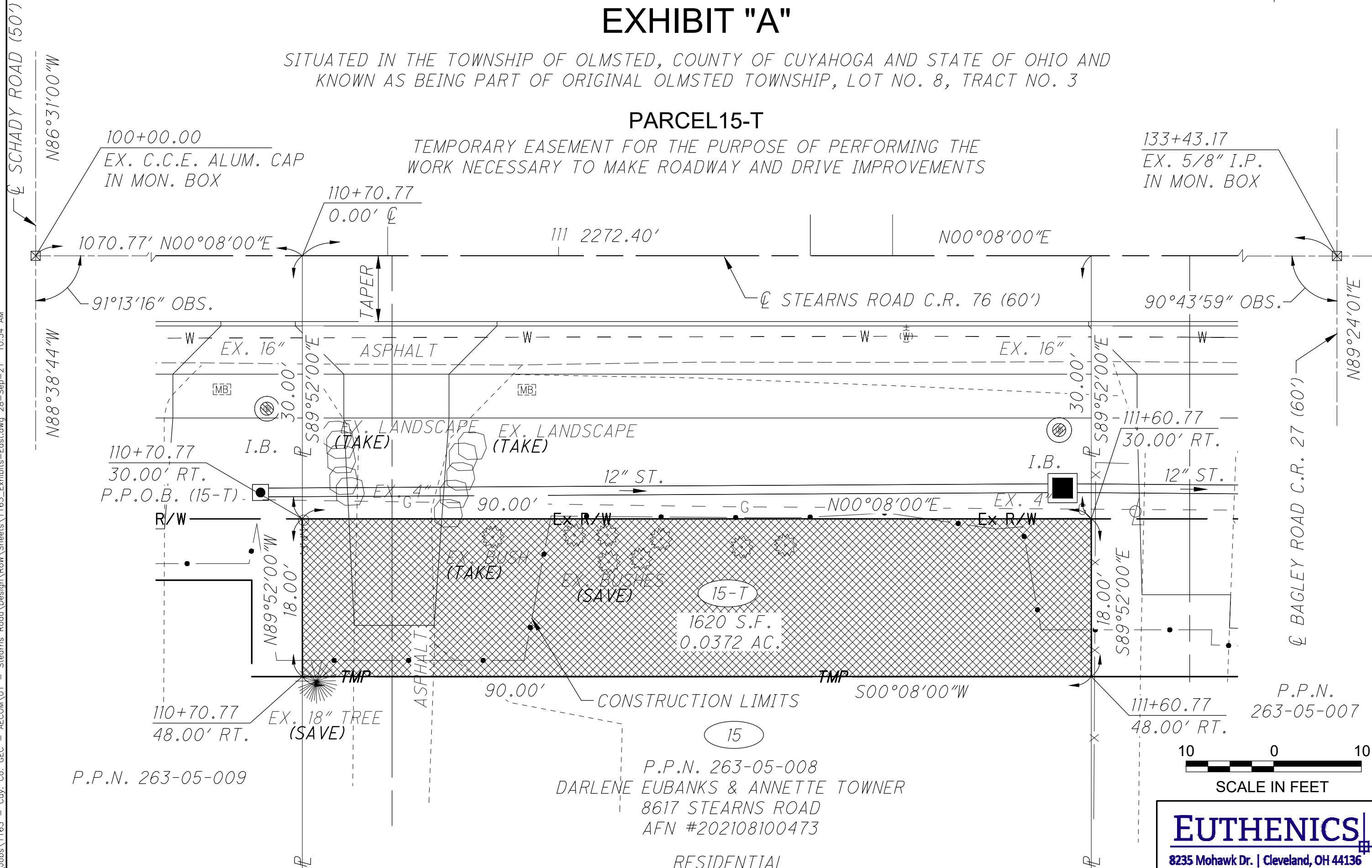

F:\Jobs\1163 - Cuy. Co. GEC - AECOM\01 - Stearns Road\Design\RoW\Sheets\1163\_Exhibits-East.dwg 28-Sep-21 10:34 AM



**EUTHENICS**  
8235 Mohawk Dr. | Cleveland, OH 44136

P.P.N. 263-05-008  
DARLENE EUBANKS & ANNETTE TOWNER  
8617 STEARNS ROAD  
AFN #202108100473

# M-5051 EXHIBIT "A"



SITUATED IN THE TOWNSHIP OF OLMSTED, COUNTY OF CUYAHOGA AND STATE OF OHIO AND KNOWN AS BEING PART OF ORIGINAL OLMSTED TOWNSHIP, LOT NO. 8, TRACT NO. 3

## PARCEL 16-T

TEMPORARY EASEMENT FOR THE PURPOSE OF PERFORMING THE WORK NECESSARY TO MAKE ROADWAY AND DRIVE IMPROVEMENTS

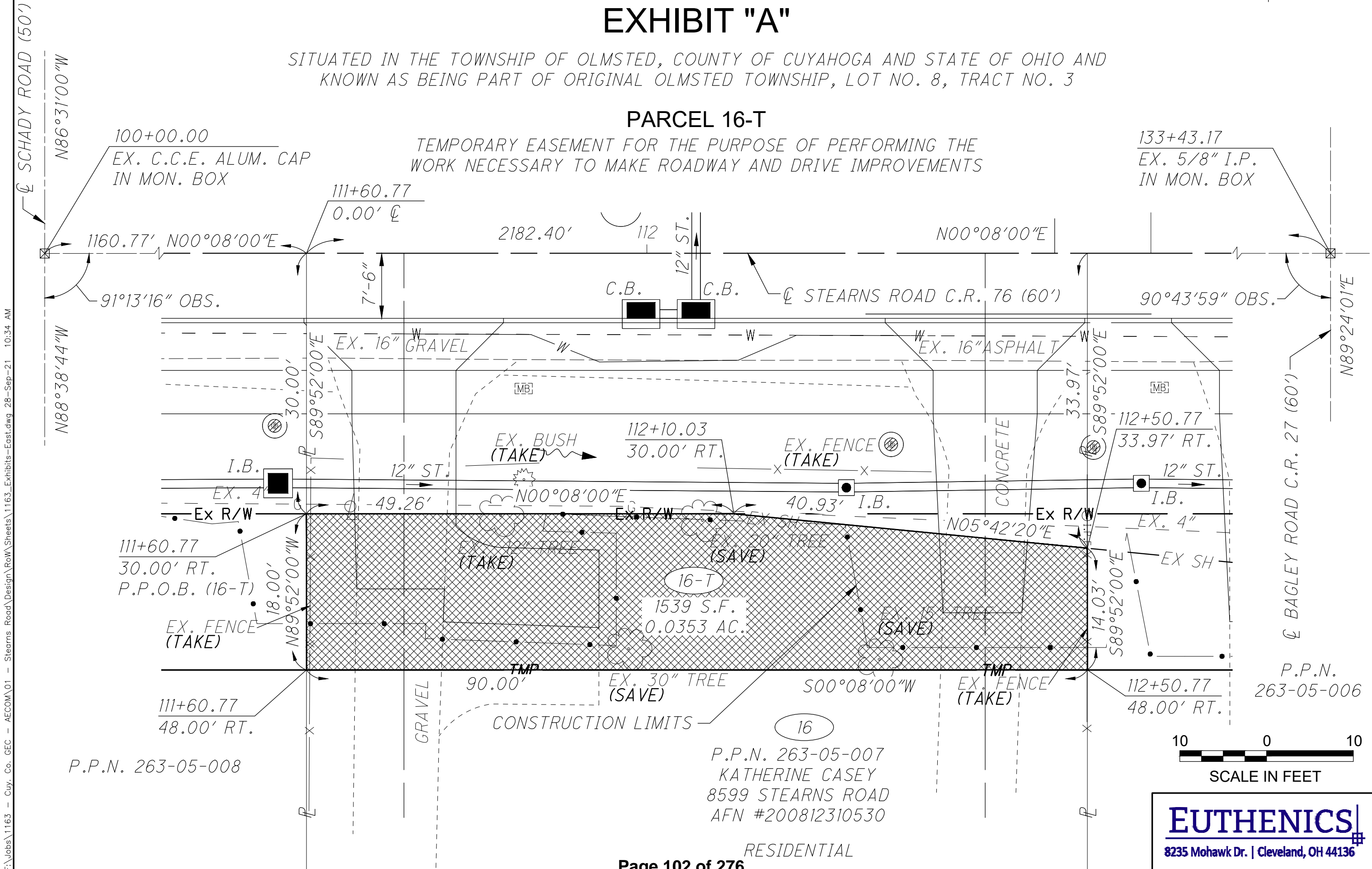

P.P.N. 263-05-008

P.P.N. 263-05-007  
KATHERINE CASEY  
8599 STEARNS ROAD  
AFN #200812310530

RESIDENTIAL

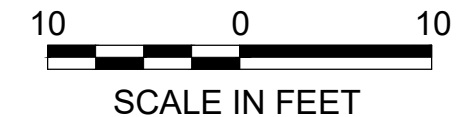

**EUTHENICS**  
8235 Mohawk Dr. | Cleveland, OH 44136

F:\Jobs\1163 - Cuy. Co. GEC - AECOM\01 - Stearns\_Road\_Design\Road\_Sheets\1163\_Exhibits-East.dwg 28-Sep-21 10:34 AM

# M-5051 EXHIBIT "A"

SITUATED IN THE TOWNSHIP OF OLMSTED,  
COUNTY OF CUYAHOGA AND STATE OF OHIO AND KNOWN AS BEING  
PART OF ORIGINAL OLMSTED TOWNSHIP, LOT NO. 8, TRACT NO. 3

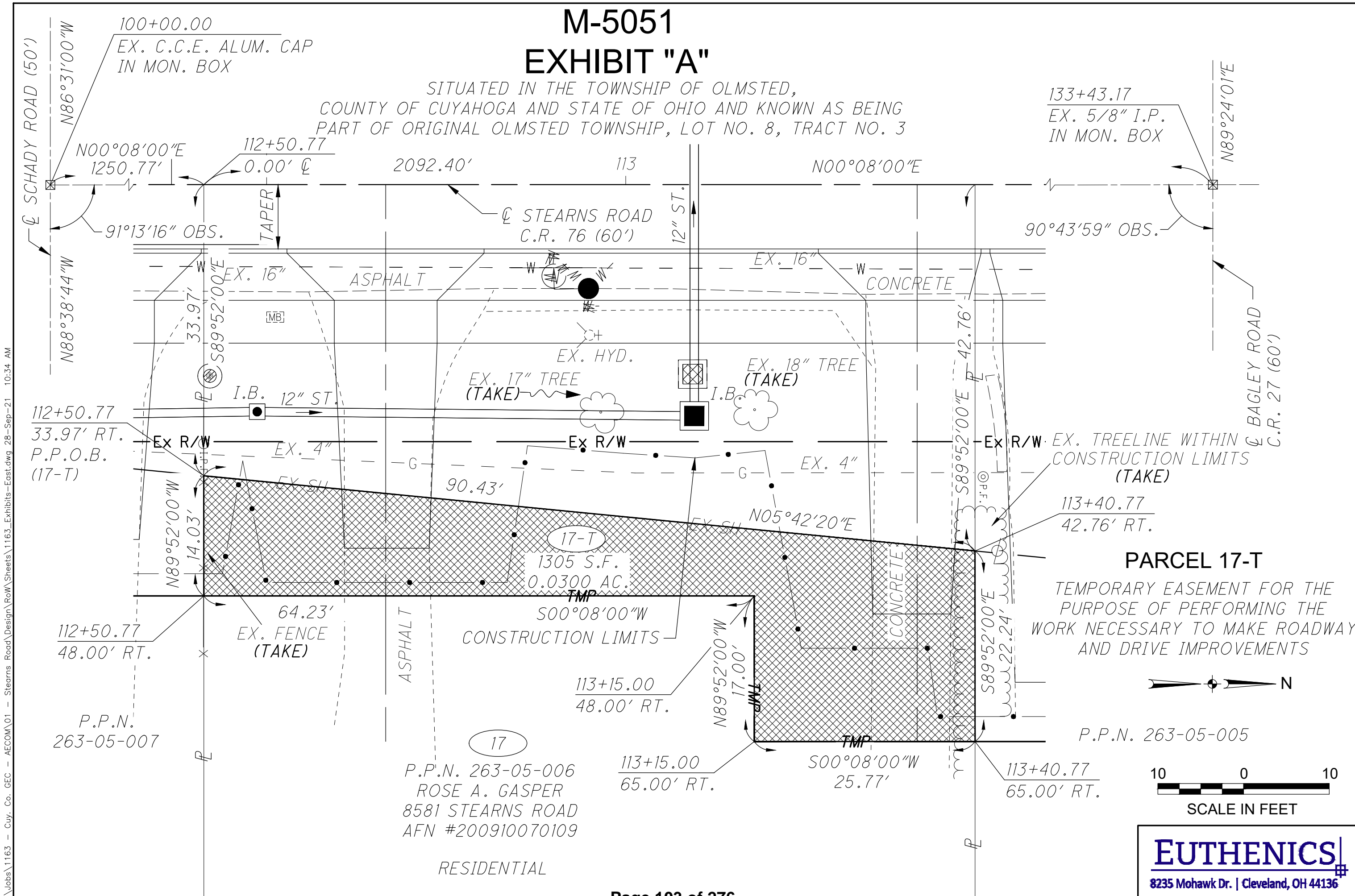

EX. TREELINE WITHIN  
CONSTRUCTION LIMITS  
(TAKE)

## PARCEL 17-T

TEMPORARY EASEMENT FOR THE  
PURPOSE OF PERFORMING THE  
WORK NECESSARY TO MAKE ROADWAY  
AND DRIVE IMPROVEMENTS

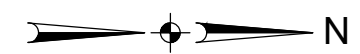

SCALE IN FEET

**EUTHENICS**  
8235 Mohawk Dr. | Cleveland, OH 44136

P.P.N. 263-05-006  
ROSE A. GASPER  
8581 STEARNS ROAD  
AFN #200910070109

RESIDENTIAL

F:\Jobs\1163 - Cuy. Co. GEC - AECOM\01 - Stearns Road\Design\Row\Sheets\1163\_Exhibits-East.dwg 28-Sep-21 10:34 AM

# M-5051 EXHIBIT "A"



SITUATED IN THE TOWNSHIP OF OLMSTED,  
COUNTY OF CUYAHOGA AND STATE OF OHIO AND KNOWN AS BEING  
PART OF ORIGINAL OLMSTED TOWNSHIP, LOT NO. 8, TRACT NO. 3

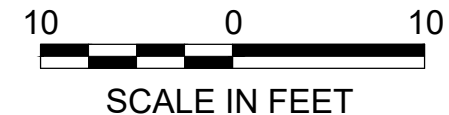
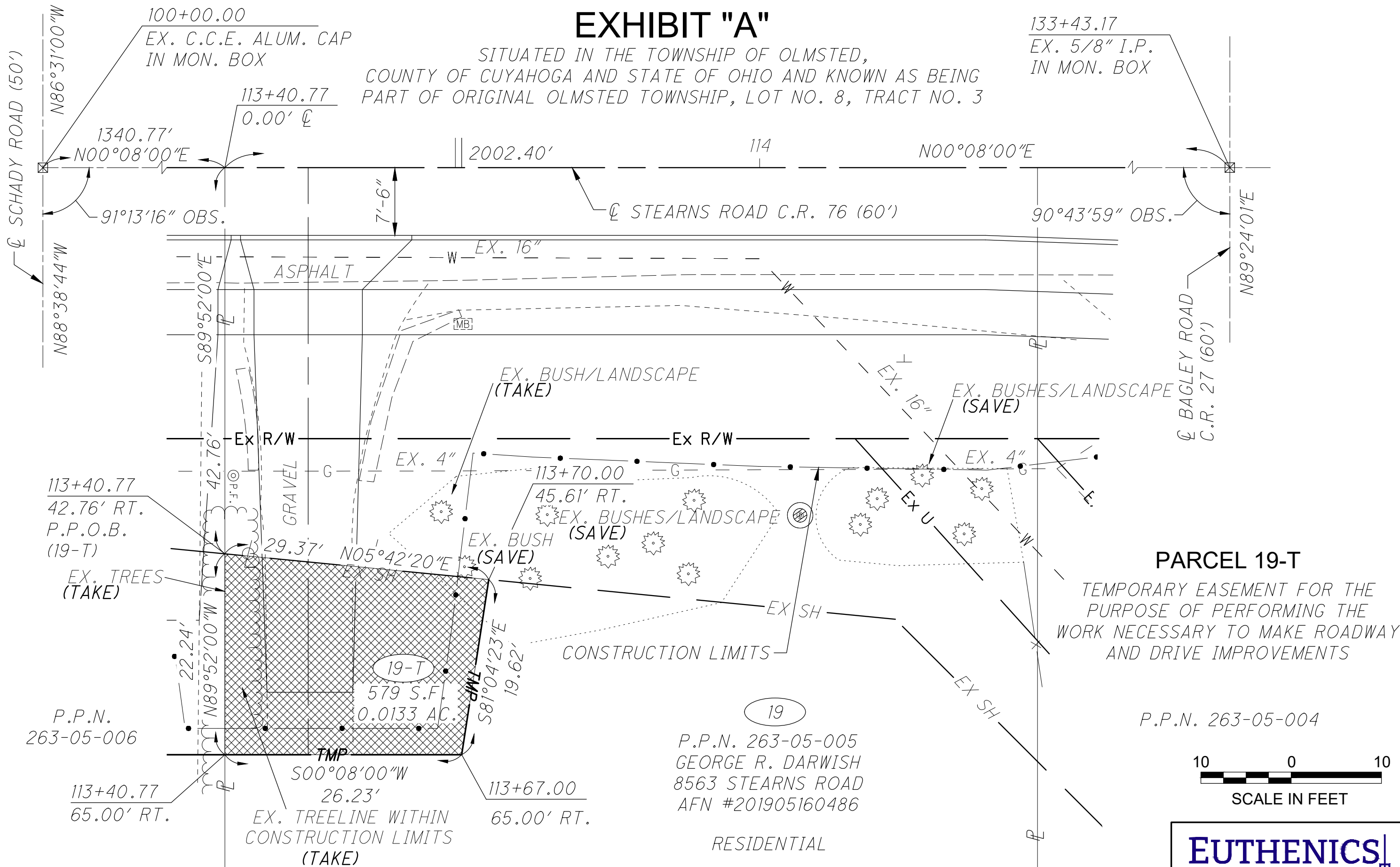

**EUTHENICS**  
8235 Mohawk Dr. | Cleveland, OH 44136

F:\Jobs\1163 - Cuy. Co. GEC - AECOM\01 - Stearns Road\Design\Row\Sheets\1163\_Exhibits-East.dwg 28-Sep-21 10:34 AM



# M-5051 EXHIBIT "A"

SITUATED IN THE TOWNSHIP OF OLMSTED, COUNTY OF CUYAHOGA AND STATE OF OHIO AND KNOWN AS BEING PART OF ORIGINAL OLMSTED TOWNSHIP, LOT NO. 9, TRACT NO. 2

## PARCEL 30-S & 30-T

TEMPORARY EASEMENT FOR THE PURPOSE OF PERFORMING THE WORK NECESSARY TO MAKE ROADWAY AND DRIVE IMPROVEMENTS  
STORM SEWER EASEMENT TO CONSTRUCT AND MAINTAIN A STORM SEWER

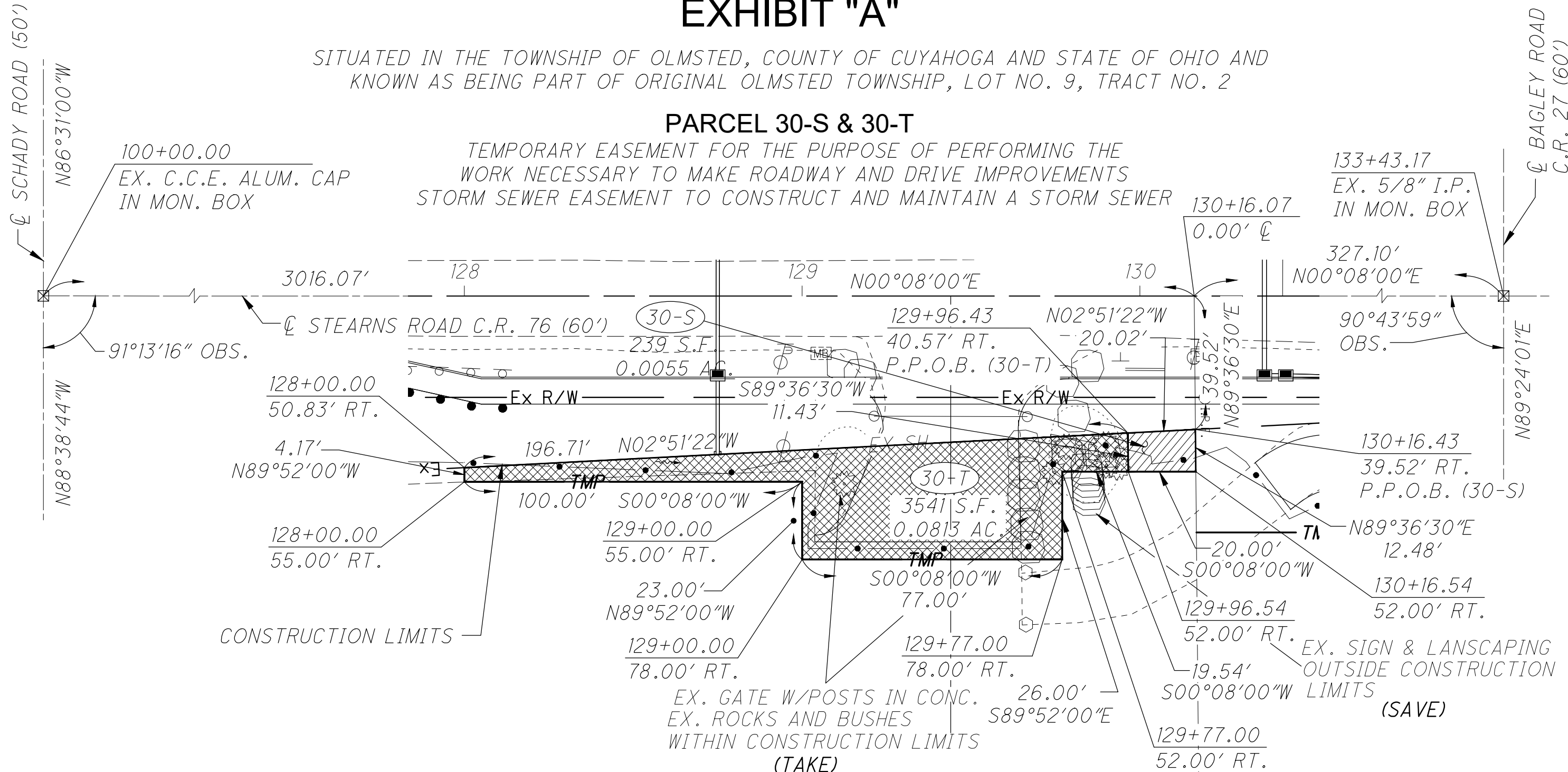

30  
P.P.N. 263-01-020  
STRIKE ZONE INC.  
8501 STEARNS ROAD  
DEED VOL. 87-1853, P. 36

COMMERCIAL

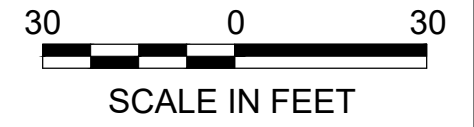
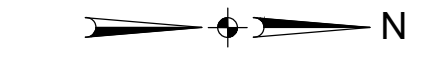

**EUTHENICS**  
8235 Mohawk Dr. | Cleveland, OH 44136

F:\Jobs\1163 - Cuy. Co. GEC - AECOM\01 - Stearns Road\Design\RoW\Sheets\1163\_Exhibits-East.dwg 28-Sep-21 10:34 AM

# M-5051 EXHIBIT "A"



SITUATED IN THE TOWNSHIP OF OLMSTED, COUNTY OF CUYAHOGA AND STATE OF OHIO AND KNOWN AS BEING PART OF ORIGINAL OLMSTED TOWNSHIP, LOT NO. 9, TRACT NO. 2

## PARCEL 31-SH

HIGHWAY EASEMENT FOR THE PURPOSE OF PERFORMING THE WORK NECESSARY TO MAKE ROADWAY IMPROVEMENTS

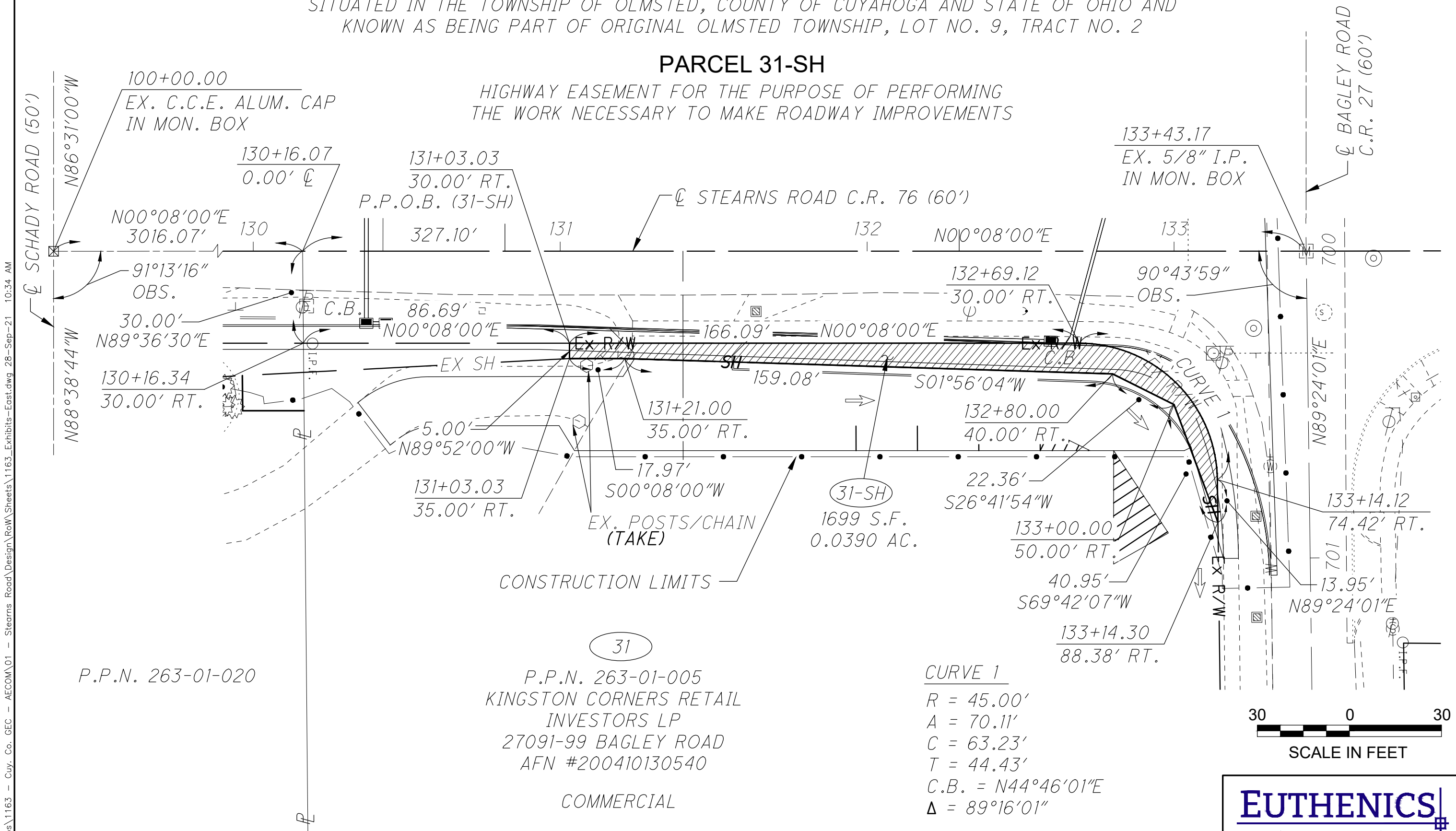

P.P.N. 263-01-020

31  
P.P.N. 263-01-005  
KINGSTON CORNERS RETAIL  
INVESTORS LP  
27091-99 BAGLEY ROAD  
AFN #200410130540  
COMMERCIAL

CURVE 1  
R = 45.00'  
A = 70.11'  
C = 63.23'  
T = 44.43'  
C.B. = N44°46'01"E  
Δ = 89°16'01"



**EUTHENICS**  
8235 Mohawk Dr. | Cleveland, OH 44136

F:\Jobs\1163 - Cuy. Co. GEC - AECOM\01 - Stearns Road\Design\RoW\Sheets\1163\_ Exhibits-East.dwg 28-Sep-21 10:34 AM

# M-5051 EXHIBIT "A"



SITUATED IN THE TOWNSHIP OF OLMSTED, COUNTY OF CUYAHOGA AND STATE OF OHIO AND  
KNOWN AS BEING PART OF ORIGINAL OLMSTED TOWNSHIP, LOT NO. 9, TRACT NO. 2

## PARCEL 31-T

TEMPORARY EASEMENT FOR THE PURPOSE OF PERFORMING THE  
WORK NECESSARY TO MAKE ROADWAY AND DRIVE IMPROVEMENTS

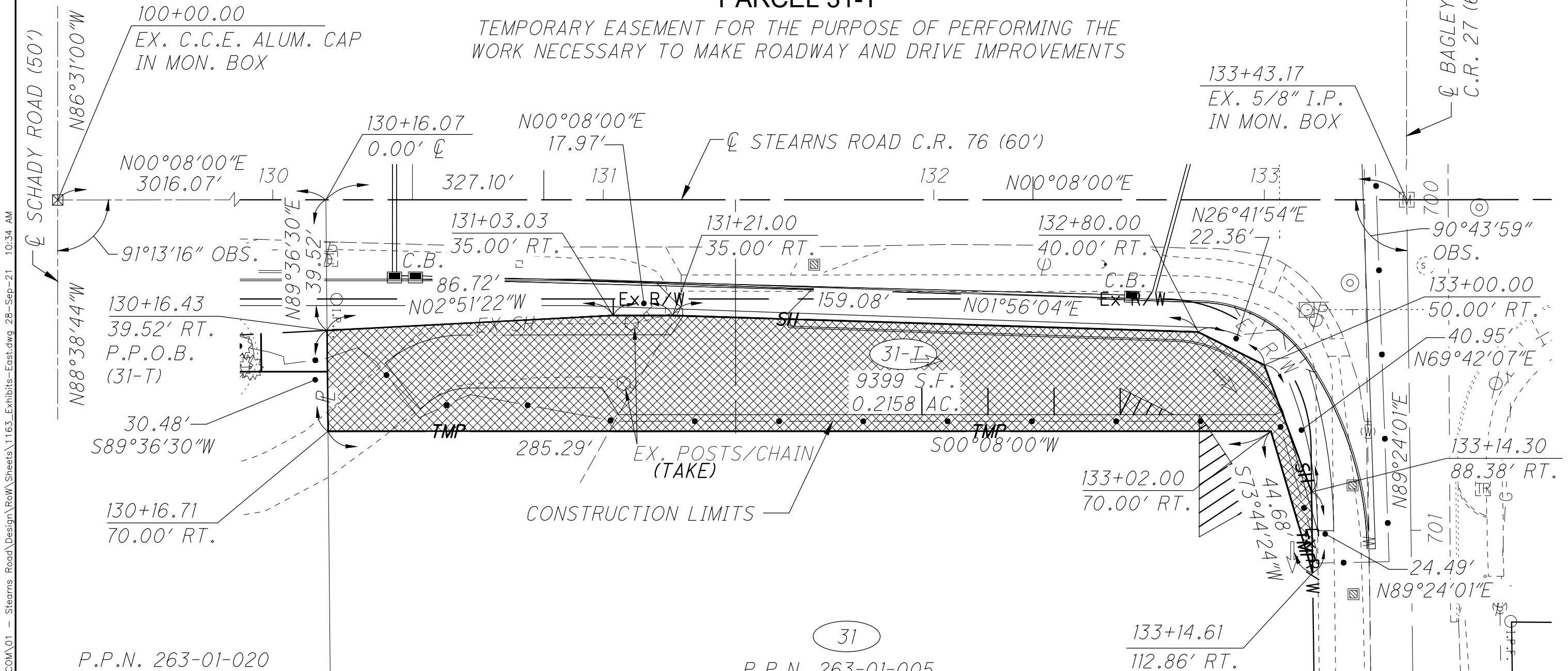

P.P.N. 263-01-020

31  
P.P.N. 263-01-005  
KINGSTON CORNERS RETAIL  
INVESTORS LP  
27091-99 BAGLEY ROAD  
AFN #200410130540

COMMERCIAL

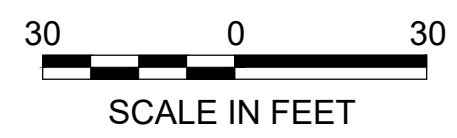

**EUTHENICS**  
8235 Mohawk Dr. | Cleveland, OH 44136

F:\Jobs\1163 - Cuy. Co. GEC - AECOM\01 - Stearns Road\Design\Row\Sheets\1163\_ Exhibits-East.dwg 28-Sep-21 10:34 AM



F:\Jobs\1163 - Cuy. Co. GEC - AECOM\01 - Stearns\_Road\Design\Row\Sheets\1163\_Exhibits\West.dwg 28-Sep-21 10:14 AM

2

P.P.N. 265-09-023  
JAMES P. HART  
SCHADY ROAD  
LOT 3  
AFN #201909200377

RESIDENTIAL  
(VACANT)

CURVE 1  
R = 40.00'  
A = 65.17'  
C = 58.20'  
T = 42.41'  
C.B. = S46°48'30"W  
Δ = 93°21'00"

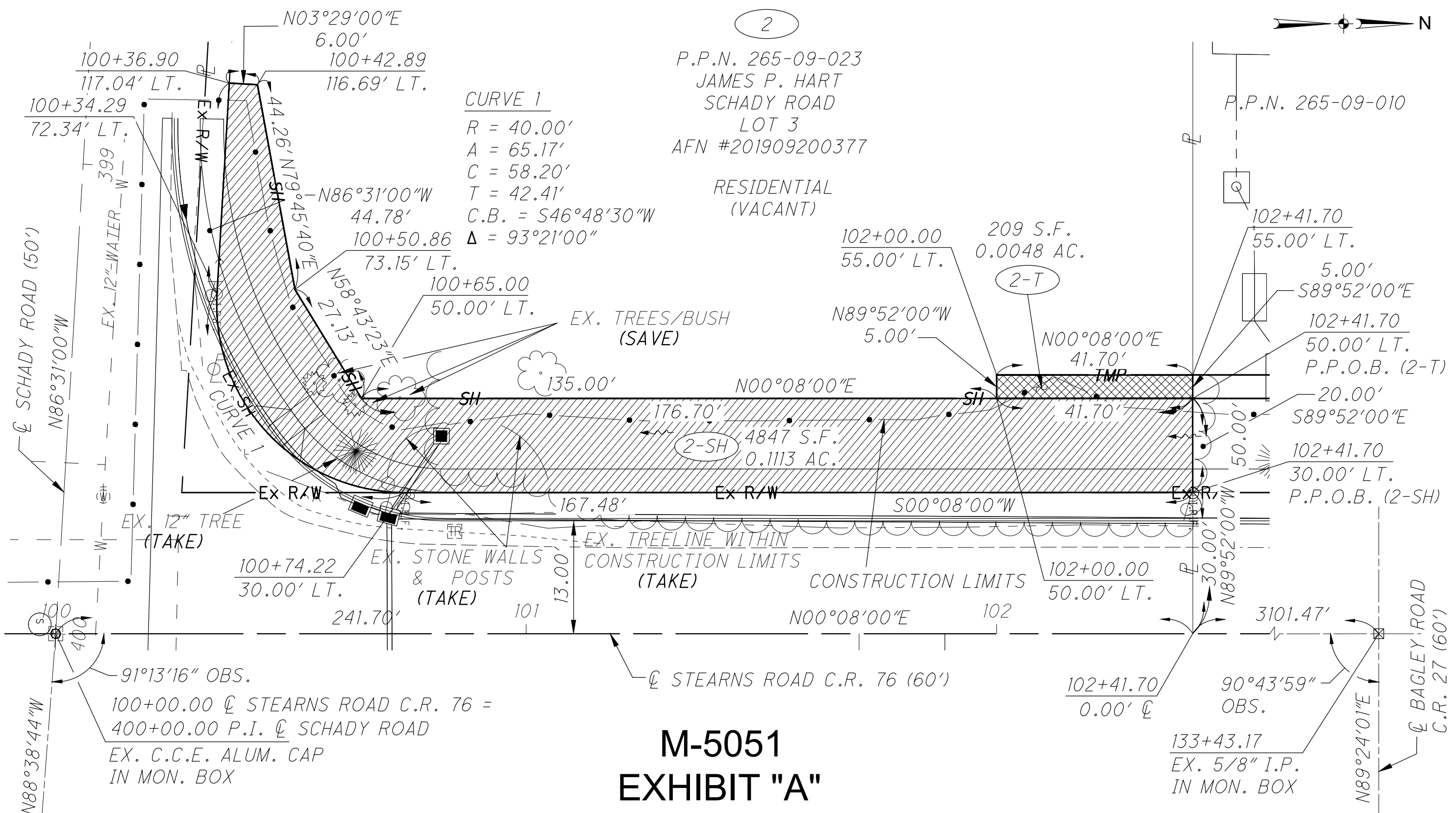

# M-5051 EXHIBIT "A"

SITUATED IN THE TOWNSHIP OF OLMSTED, COUNTY OF CUYAHOGA AND STATE OF OHIO AND KNOWN AS BEING PART OF ORIGINAL OLMSTED TOWNSHIP, LOT NO. 8, TRACT NO. 3

## PARCEL 2-T & 2-SH

TEMPORARY EASEMENT AND HIGHWAY EASEMENT FOR THE PURPOSE OF PERFORMING THE WORK NECESSARY TO MAKE ROADWAY IMPROVEMENTS



**EUTHENICS**  
8235 Mohawk Dr. | Cleveland, OH 44136



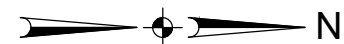

4

P.P.N. 265-09-023

P.P.N. 265-09-010  
GEORGE B. DAMERON  
8760 STEARNS ROAD  
DEED VOL. 94-9625 P. 19

P.P.N. 265-09-018

RESIDENTIAL

EX. SEPTIC (SAVE)

EX. 18" TREE (TAKE)

CONSTRUCTION LIMITS

103+41.70  
55.00' LT.

4-T

500 S.F.  
0.0115 AC.

S89°52'00"E  
5.00'

102+41.70  
50.00' LT.  
P.P.O.B. (4-T)

N89°52'00"W  
5.00'

102+41.70  
55.00' LT.

GRAVEL

N00°08'00"E

103+41.70  
50.00' LT.

N89°52'00"W  
20.00'

50.00'

100.00'

500°08'00"W

GRA

20.00'  
S89°52'00"E

102+41.70  
30.00' LT.  
P.P.O.B. (4-SH)

N89°52'00"W  
30.00'

100.00'

4-SH 2000 S.F.  
0.0459 AC.

500°08'00"W

EX. R/W

133+43.17  
EX. 5/8" I.P.  
IN MON. BOX

100+00.00  
EX. C.C.E. ALUM. CAP  
IN MON. BOX

EX. FENCE (TAKE)

103+41.70  
30.00' LT.

241.70'

N00°08'00"E

3101.47'

N00°08'00"E

90°43'59" OBS.

91°13'16" OBS.

102+41.70  
0.00' CL

EX. TREELINE WITHIN  
CONSTRUCTION LIMITS  
(TAKE)

# M-5051 EXHIBIT "A"

CL BAGLEY ROAD C.R. 27 (60')

## PARCEL 4-T & 4-SH

SITUATED IN THE TOWNSHIP OF OLMSTED, COUNTY OF CUYAHOGA AND STATE OF OHIO AND  
KNOWN AS BEING PART OF ORIGINAL OLMSTED TOWNSHIP, LOT NO. 8, TRACT NO. 3

TEMPORARY EASEMENT AND HIGHWAY EASEMENT FOR THE PURPOSE OF PERFORMING  
THE WORK NECESSARY TO MAKE ROADWAY AND DRIVE IMPROVEMENTS

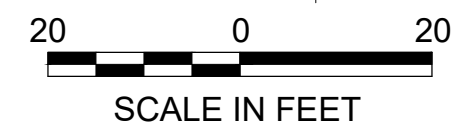

**EUTHENICS**  
8235 Mohawk Dr. | Cleveland, OH 44136

F:\Jobs\1163 - Cuy. Co. GEC - AECOM\01 - Stearns Road\Design\Row\Sheets\1163\_Exhibits\West.dwg 28-Sep-21 10:14 AM

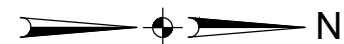

P.P.N. 265-09-010

6A

P.P.N. 265-09-018  
KATHERINECORP, LLC  
8634 STEARNS ROAD  
AFN #201712220917

P.P.N. 265-09-009

RESIDENTIAL

709 S.F.  
0.0163 AC.  
6A-T1

CONSTRUCTION LIMITS

EX. SEPTIC  
(SAVE)

103+41.70  
50.00' LT.  
P.P.O.B. (6A-T1)  
N89°52'00"W  
5.00'

104+83.50  
55.00' LT.

5.00'  
S89°52'00"E

104+83.50  
50.00' LT.

20.00'  
S89°52'00"E

133+43.17  
EX. 5/8" I.P.  
IN MON. BOX

104+83.50  
30.00' LT.

BAGLEY ROAD  
C.R. 27 (60')

N89°24'01"E

103+41.70  
30.00' LT.  
P.P.O.B. (6A-SH1)

100+00.00  
EX. C.C.E. ALUM. CAP  
IN MON. BOX

341.70' N00°08'00"E

91°13'16" OBS.

103+41.70  
0.00' CL

141.80'

141.80'

141.80'

3001.47'

N00°08'00"E

90°43'59" OBS.

STEARNS ROAD C.R. 76 (60')

# M-5051 EXHIBIT "A"

SITUATED IN THE TOWNSHIP OF OLMSTED, COUNTY OF CUYAHOGA AND STATE OF OHIO AND  
KNOWN AS BEING PART OF ORIGINAL OLMSTED TOWNSHIP, LOT NO. 8, TRACT NO. 3

## PARCEL 6A-T1 & 6A-SH1

TEMPORARY EASEMENT AND HIGHWAY EASEMENT FOR THE PURPOSE OF PERFORMING  
THE WORK NECESSARY TO MAKE ROADWAY AND DRIVE IMPROVEMENTS



**EUTHENICS**  
8235 Mohawk Dr. | Cleveland, OH 44136

F:\Jobs\1163 - Cuy. Co. GEC - AECOM\01 - Stearns Road\Design\Row\Sheets\1163\_Exhibits\West.dwg 28-Sep-21 10:14 AM

F:\Jobs\1163 - Cuy. Co. GEC - AECOM\01 - Stearns Road\Design\Row\Sheets\1163\_ Exhibits - West.dwg 28-Sep-21 10:15 AM



6

P.P.N. 265-09-018

P.P.N. 265-09-009  
 PETER C. & JOYCE K. ZWICK, CO-TR.  
 ZWICK FAMILY TRUST  
 8634 STEARNS ROAD  
 AFN #200408021367

P.P.N. 265-09-008

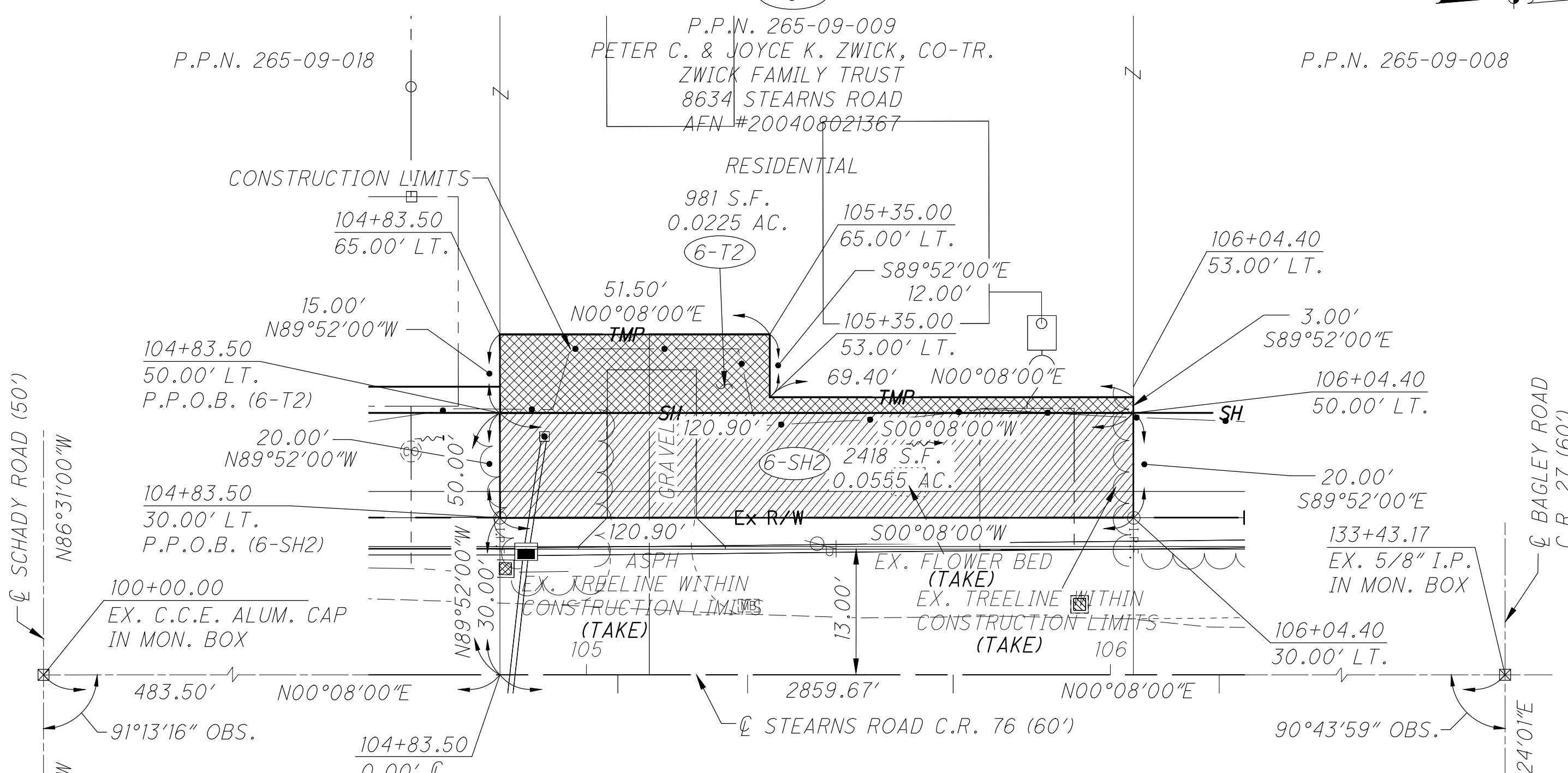

# M-5051 EXHIBIT "A"

SITUATED IN THE TOWNSHIP OF OLMSTED, COUNTY OF CUYAHOGA AND STATE OF OHIO AND KNOWN AS BEING PART OF ORIGINAL OLMSTED TOWNSHIP, LOT NO. 8, TRACT NO. 3

## PARCEL 6-T2 & 6-SH2

TEMPORARY EASEMENT AND HIGHWAY EASEMENT FOR THE PURPOSE OF PERFORMING THE WORK NECESSARY TO MAKE ROADWAY AND DRIVE IMPROVEMENTS

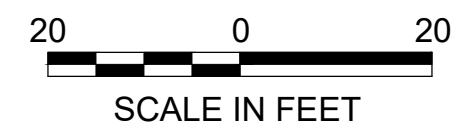

**EUTHENICS**  
 8235 Mohawk Dr. | Cleveland, OH 44136

F:\Jobs\1163 - Cuy. Co. GEC - AECOM\01 - Stearns Road\Design\Row\Sheets\1163\_Exhibits=West.dwg 28-Sep-21 10:15 AM

6

P.P.N. 265-09-009

P.P.N. 265-09-008  
PETER C. & JOYCE K. ZWICK, CO-TR.  
ZWICK FAMILY TRUST  
8634 STEARNS ROAD  
AFN #200408021367

P.P.N. 265-09-007

RESIDENTIAL

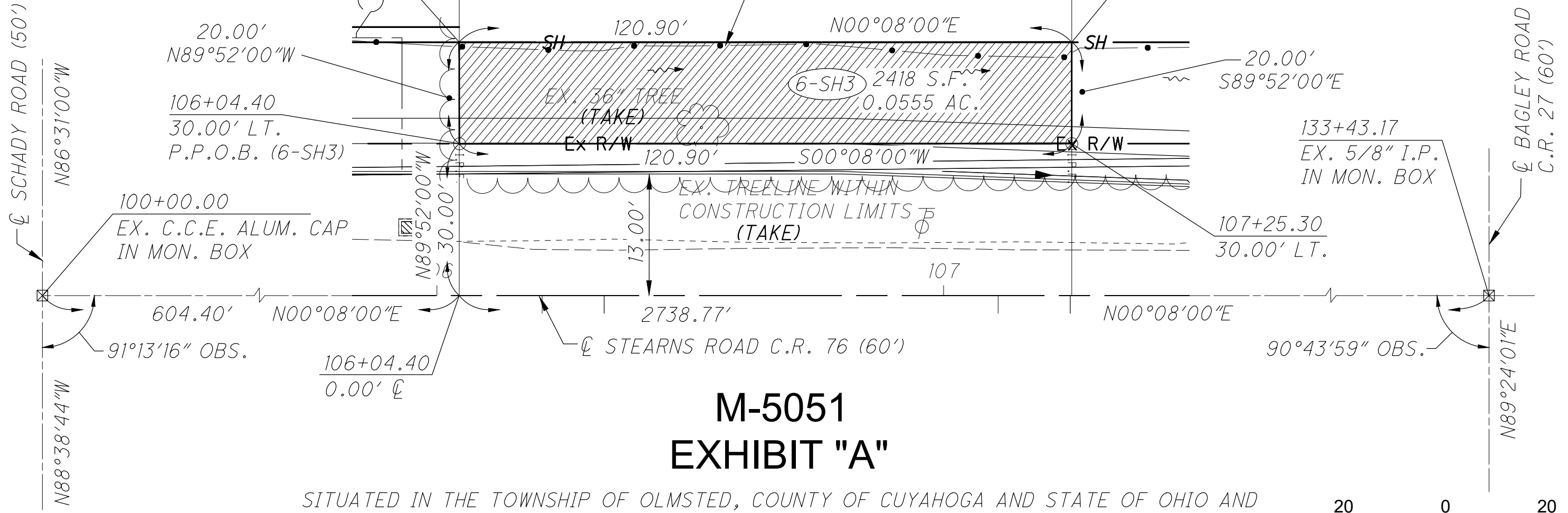
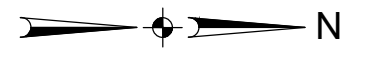

# M-5051 EXHIBIT "A"

SITUATED IN THE TOWNSHIP OF OLMSTED, COUNTY OF CUYAHOGA AND STATE OF OHIO AND KNOWN AS BEING PART OF ORIGINAL OLMSTED TOWNSHIP, LOT NO. 8, TRACT NO. 3

## PARCEL 6-SH3

HIGHWAY EASEMENT FOR THE PURPOSE OF PERFORMING THE WORK NECESSARY TO MAKE ROADWAY IMPROVEMENTS



**EUTHENICS**  
8235 Mohawk Dr. | Cleveland, OH 44136



F:\Jobs\1163 - Cuy. Co. GEC - AECOM\01 - Stearns Road\Design\Row\Sheets\1163 Exhibits-West.dwg 28-Sep-21 10:15 AM

6

P.P.N. 265-09-007  
PETER C. & JOYCE K. ZWICK, CO-TR.  
ZWICK FAMILY TRUST PARCEL 1  
8634 STEARNS ROAD  
AFN #200408021367

P.P.N.  
265-09-008

P.P.N.  
265-09-006



SCHADY ROAD (50')

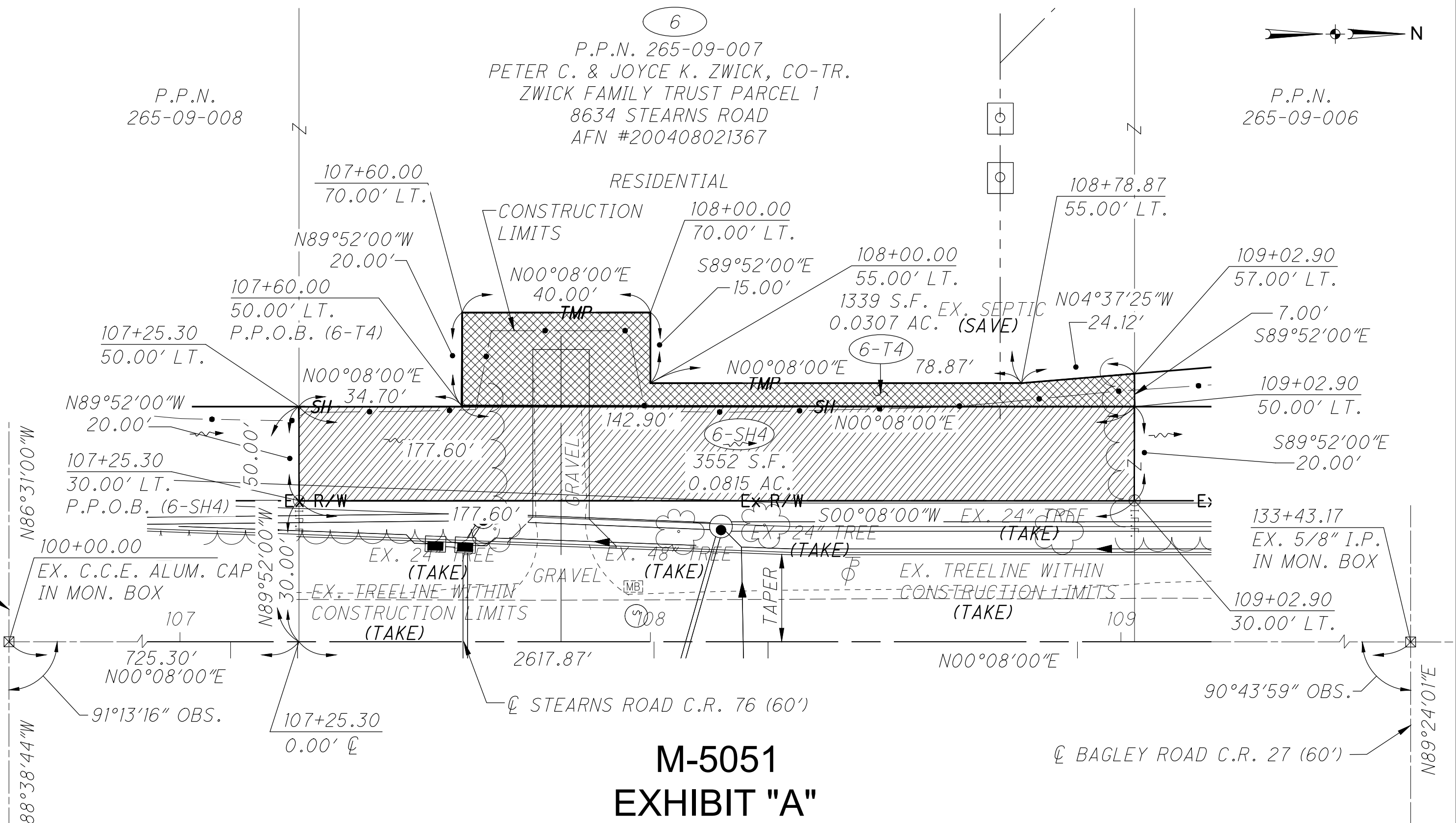

# M-5051 EXHIBIT "A"

SITUATED IN THE TOWNSHIP OF OLMSTED, COUNTY OF CUYAHOGA AND STATE OF OHIO AND KNOWN AS BEING PART OF ORIGINAL OLMSTED TOWNSHIP, LOT NO. 8, TRACT NO. 3

## PARCEL 6-SH4 & 6-T4

TEMPORARY EASEMENT AND HIGHWAY EASEMENT FOR THE PURPOSE OF PERFORMING THE WORK NECESSARY TO MAKE ROADWAY AND DRIVE IMPROVEMENTS

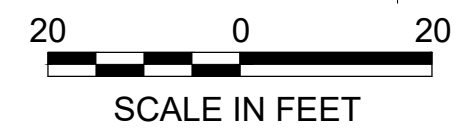

**EUTHENICS**  
8235 Mohawk Dr. | Cleveland, OH 44136

6

P.P.N. 265-09-006  
PETER C. & JOYCE K. ZWICK, CO-TR.  
ZWICK FAMILY TRUST  
8634 STEARNS ROAD  
AFN #200408021367

RESIDENTIAL

P.P.N.  
265-09-007

P.P.N.  
265-09-005

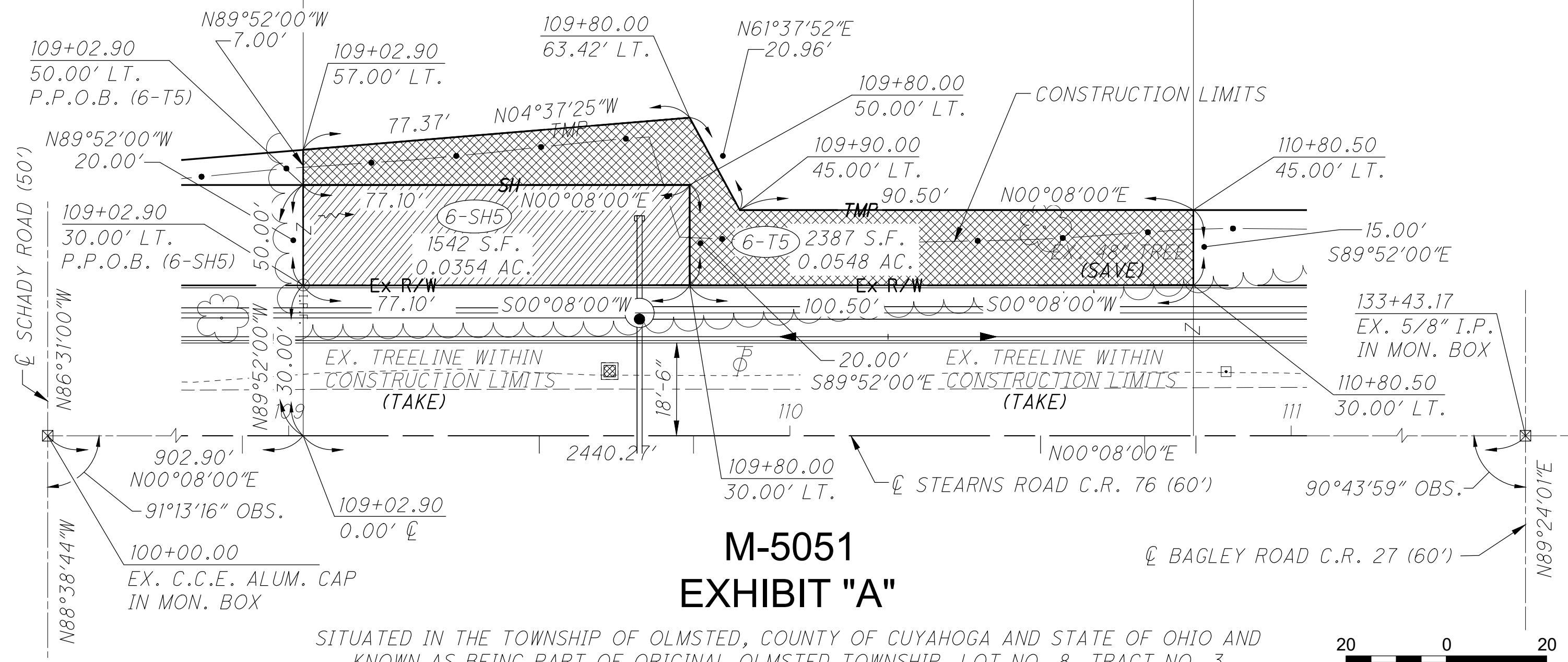

# M-5051 EXHIBIT "A"

SITUATED IN THE TOWNSHIP OF OLMSTED, COUNTY OF CUYAHOGA AND STATE OF OHIO AND KNOWN AS BEING PART OF ORIGINAL OLMSTED TOWNSHIP, LOT NO. 8, TRACT NO. 3

## PARCEL 6-SH5 & 6-T5

TEMPORARY EASEMENT AND HIGHWAY EASEMENT FOR THE PURPOSE OF PERFORMING THE WORK NECESSARY TO MAKE ROADWAY IMPROVEMENTS

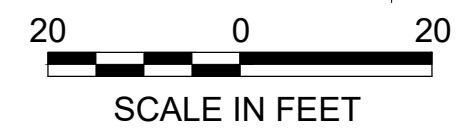

**EUTHENICS**  
8235 Mohawk Dr. | Cleveland, OH 44136

F:\Jobs\1163 - Cuy. Co. GEC - AECOM\01 - Stearns Road\Design\Row\Sheets\1163\_ Exhibits - West.dwg 28-Sep-21 10:15 AM

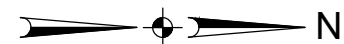

P.P.N.  
265-09-006

6  
P.P.N. 265-09-005  
PETER C. & JOYCE K.  
ZWICK, CO-TR.  
ZWICK FAMILY TRUST  
8634 STEARNS ROAD  
AFN #200408021367

P.P.N.  
265-09-017

RESIDENTIAL

☐ SCHADY ROAD (50')

N86°31'00"W

N88°38'44"W

100+00.00  
EX. C.C.E. ALUM. CAP  
IN MON. BOX

EX. TREELINE WITHIN  
CONSTRUCTION LIMITS  
(TAKE)

1080.50'

91°13'16" OBS.

15.00'  
N89°52'00"W

110+80.50  
30.00' LT.

P.P.O.B. (6-T6)

110+80.50  
45.00' LT.

111+08.00  
45.00' LT.

N89°52'00"W  
17.00'

N00°08'00"E  
27.50'

1376 S.F.  
0.0316 AC.

6-T6

EX. P/W

N89°52'00"W  
30.00'

N00°08'00"E

110+80.50  
0.00' ☐

111+08.00  
62.00' LT.

N00°08'00"E  
30.10'

TMP

GRAVEL

GRAV

32.00'

S89°52'00"E

CONSTRUCTION LIMITS

EX. LANDSCAPING  
& ROCKS  
(TAKE)

111+38.10  
30.00' LT.

N00°08'00"E

90°43'59" OBS.

133+43.17  
EX. 5/8" I.P.  
IN MON. BOX

N89°24'01"E

☐ BAGLEY ROAD C.R. 27 (60')

# M-5051 EXHIBIT "A"

SITUATED IN THE TOWNSHIP OF OLMSTED, COUNTY OF CUYAHOGA AND STATE OF OHIO AND  
KNOWN AS BEING PART OF ORIGINAL OLMSTED TOWNSHIP, LOT NO. 8, TRACT NO. 3

## PARCEL 6-T6

TEMPORARY EASEMENT FOR THE PURPOSE OF PERFORMING THE  
WORK NECESSARY TO MAKE ROADWAY AND DRIVE IMPROVEMENTS



**EUTHENICS**  
8235 Mohawk Dr. | Cleveland, OH 44136

F:\Jobs\1163 - Cuy. Co. GEC - AECOM\01 - Stearns Road\Design\Row\Sheets\1163\_Exhibits-West.dwg 28-Sep-21 10:15 AM

F:\Jobs\1163 - Cuy. Co. GEC - AECOM\01 - Stearns\_Road\Design\Row\Sheets\1163\_Exhibits\West.dwg 28-Sep-21 10:15 AM

6

P.P.N. 265-09-017  
PETER C. ZWICK, TR.  
ZWICK FAMILY TRUST  
8598 STEARNS ROAD  
AFN #201402070474

P.P.N. 265-09-005

P.P.N. 265-09-004

RESIDENTIAL

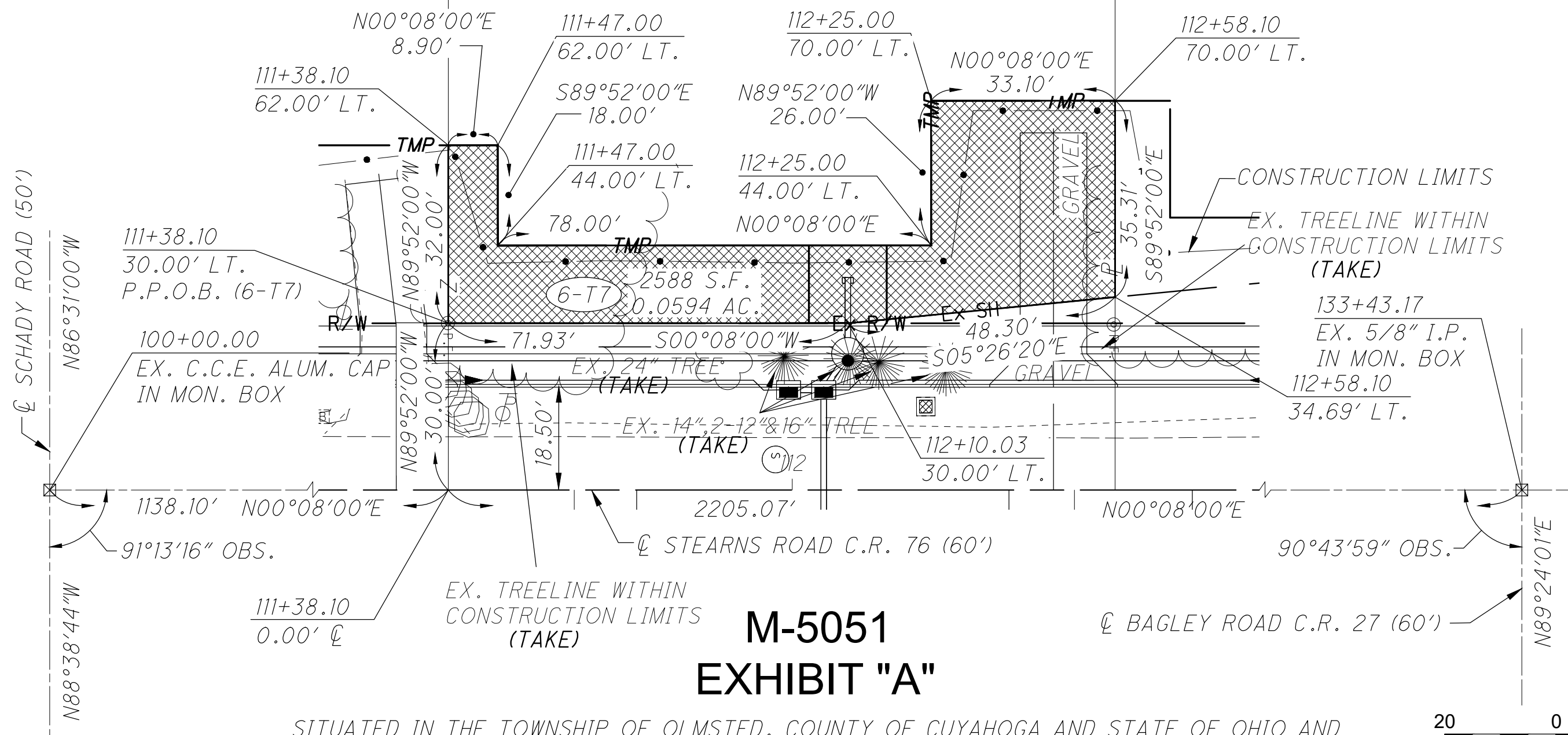

# M-5051 EXHIBIT "A"

SITUATED IN THE TOWNSHIP OF OLMSTED, COUNTY OF CUYAHOGA AND STATE OF OHIO AND KNOWN AS BEING PART OF ORIGINAL OLMSTED TOWNSHIP, LOT NO. 8, TRACT NO. 3

PARCEL 6-T7

TEMPORARY EASEMENT FOR THE PURPOSE OF PERFORMING THE WORK NECESSARY TO MAKE ROADWAY AND DRIVE IMPROVEMENTS

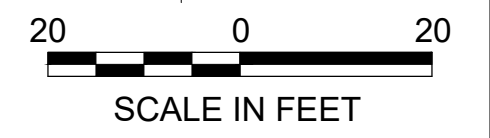
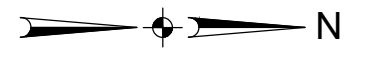

**EUTHENICS**  
8235 Mohawk Dr. | Cleveland, OH 44136



18

P.P.N. 265-09-017

P.P.N. 265-09-004  
JAMES E. BULLEN  
8580 STEARNS ROAD  
DEED VOL. 86-1165 P. 19

P.P.N. 265-09-003

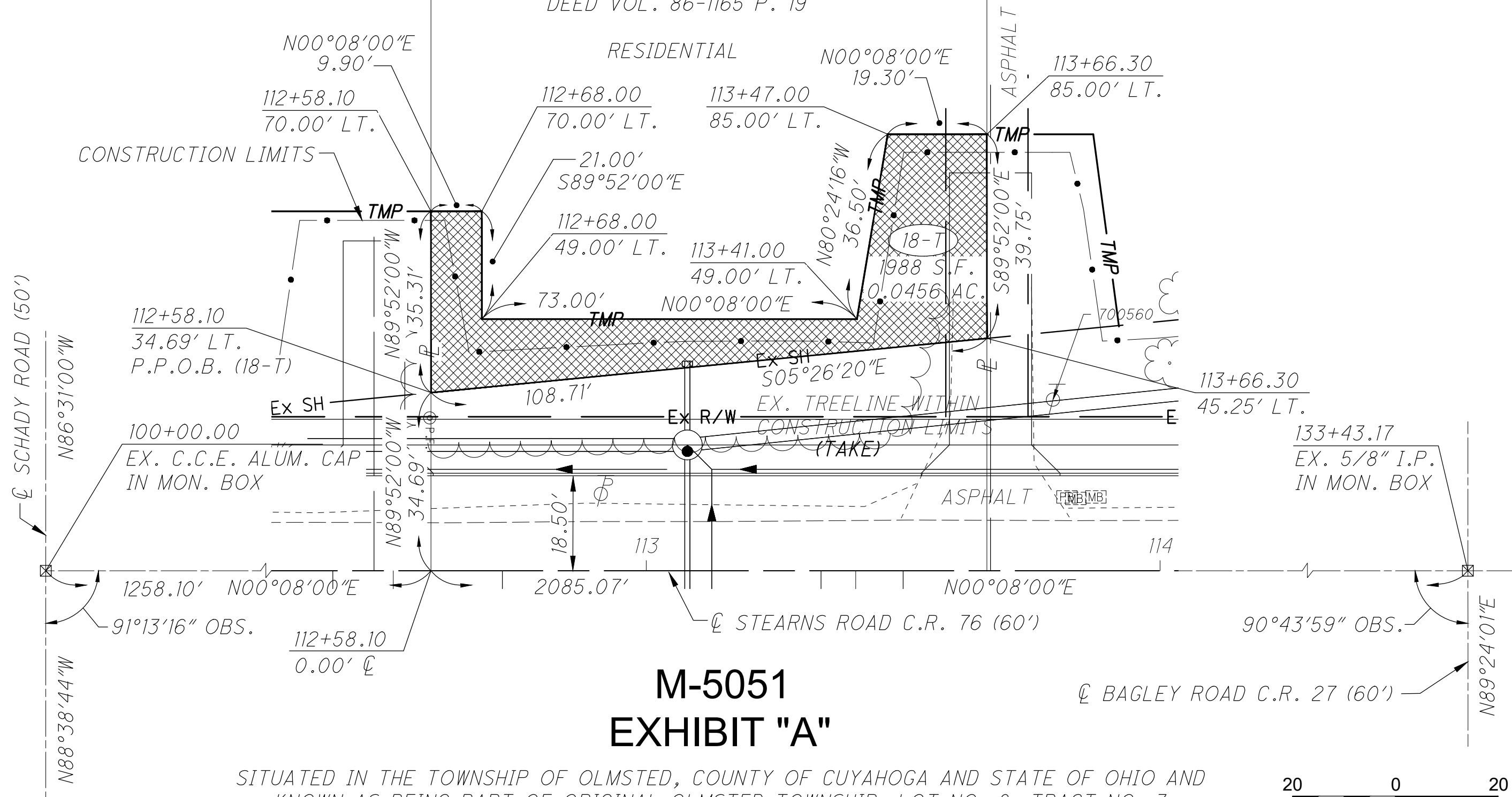

# M-5051 EXHIBIT "A"

SITUATED IN THE TOWNSHIP OF OLMSTED, COUNTY OF CUYAHOGA AND STATE OF OHIO AND KNOWN AS BEING PART OF ORIGINAL OLMSTED TOWNSHIP, LOT NO. 8, TRACT NO. 3

## PARCEL 18-T

TEMPORARY EASEMENT FOR THE PURPOSE OF PERFORMING THE WORK NECESSARY TO MAKE ROADWAY AND DRIVE IMPROVEMENTS



**EUTHENICS**  
8235 Mohawk Dr. | Cleveland, OH 44136

F:\Jobs\1163 - Cuy. Co. GEC - AECOM\01 - Stearns Road\Design\Row\Sheets\1163\_Exhibits-West.dwg 28-Sep-21 10:16 AM

F:\Jobs\1163 - Cuy. Co. GEC - AECOM\01 - Stearns Road\Design\Row\Sheets\1163\_ Exhibits-West.dwg 28-Sep-21 10:16 AM

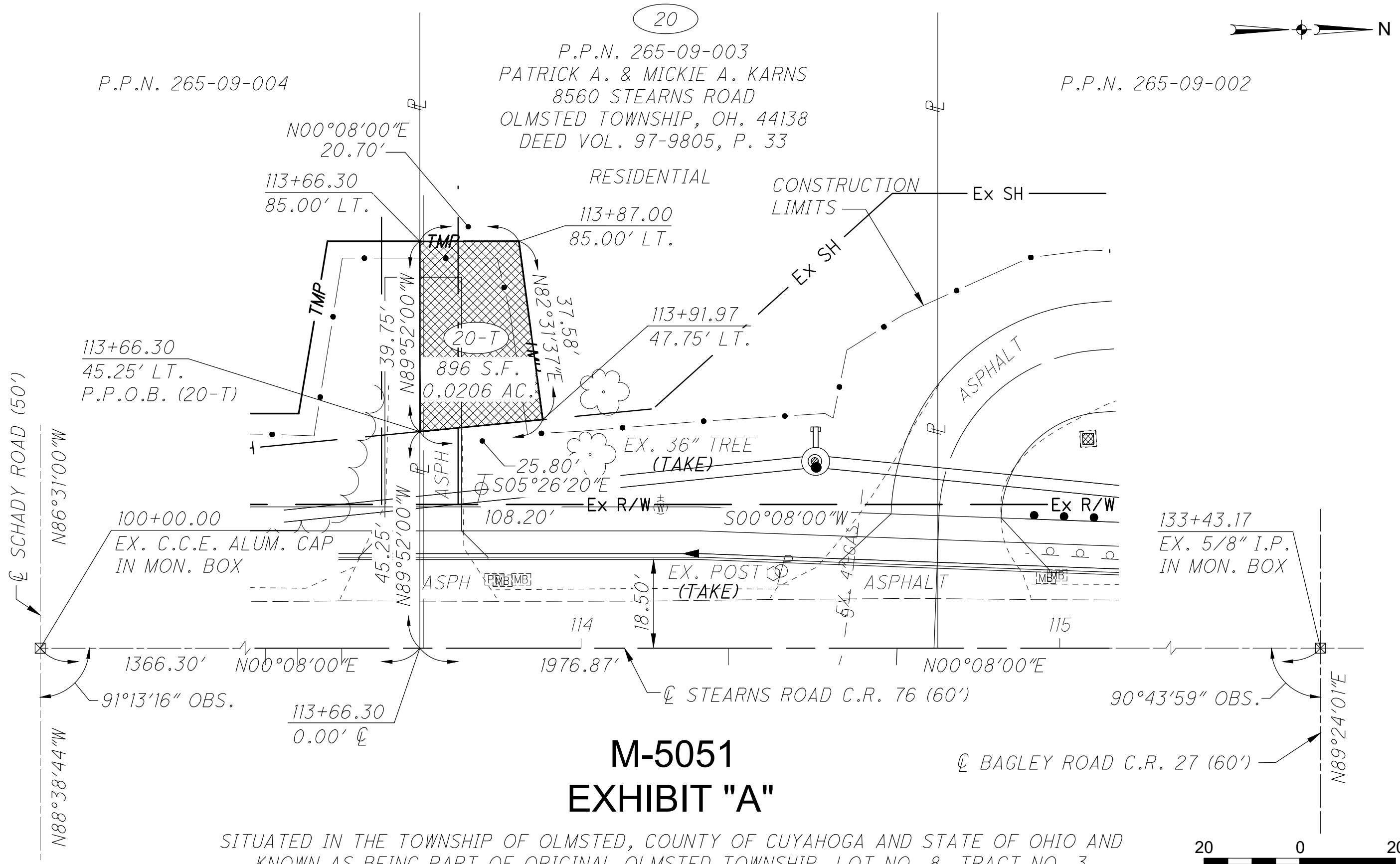

# M-5051 EXHIBIT "A"

SITUATED IN THE TOWNSHIP OF OLMSTED, COUNTY OF CUYAHOGA AND STATE OF OHIO AND KNOWN AS BEING PART OF ORIGINAL OLMSTED TOWNSHIP, LOT NO. 8, TRACT NO. 3

## PARCEL 20-T

TEMPORARY EASEMENT FOR THE PURPOSE OF PERFORMING THE WORK NECESSARY TO MAKE ROADWAY AND DRIVE IMPROVEMENTS

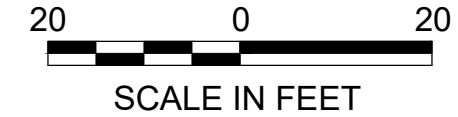

**EUTHENICS**  
8235 Mohawk Dr. | Cleveland, OH 44136

P.P.N. 265-09-004

20  
P.P.N. 265-09-003  
PATRICK A. & MICKIE A. KARNs  
8560 STEARNS ROAD  
OLMSTED TOWNSHIP, OH. 44138  
DEED VOL. 97-9805, P. 33

P.P.N. 265-09-002

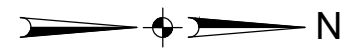

CL SCHADY ROAD (50')

CL STEARNS ROAD C.R. 76 (60')

CL BAGLEY ROAD C.R. 27 (60')

113+66.30  
45.25' LT.  
P.P.O.B. (20-T)

N00°08'00"E  
20.70'

113+66.30  
85.00' LT.

113+87.00  
85.00' LT.

113+91.97  
47.75' LT.

100+00.00  
EX. C.C.E. ALUM. CAP  
IN MON. BOX

108.20' EX R/W

133+43.17  
EX. 5/8" I.P.  
IN MON. BOX

91°13'16" OBS.

113+66.30  
0.00' CL

1976.87'

90°43'59" OBS.

N88°38'44"W

N00°08'00"E

1976.87'

N00°08'00"E

N89°24'01"E

113+66.30  
0.00' CL

114

115

M-5051

EXHIBIT "A"

PARCEL 20-T

TEMPORARY EASEMENT FOR THE PURPOSE OF PERFORMING THE WORK NECESSARY TO MAKE ROADWAY AND DRIVE IMPROVEMENTS

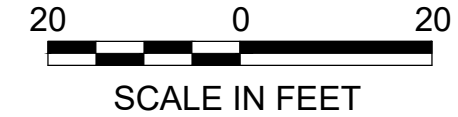

**EUTHENICS**  
8235 Mohawk Dr. | Cleveland, OH 44136

27

P.P.N. 265-04-013  
THOMAS P. & DONNA J. GALLAGHER,  
TRUSTEES OF  
THE GALLAGHER FAMILY TRUST  
27133 BAGLEY ROAD  
AFN #201502120315  
RESIDENTIAL



EX. 7", 8", 6" & 8" TREES  
(SAVE)

EX. 9", 8" & 2-18" TREES  
(TAKE)

SCHADY ROAD (50')

BAGLEY ROAD  
C.R. 27 (60')

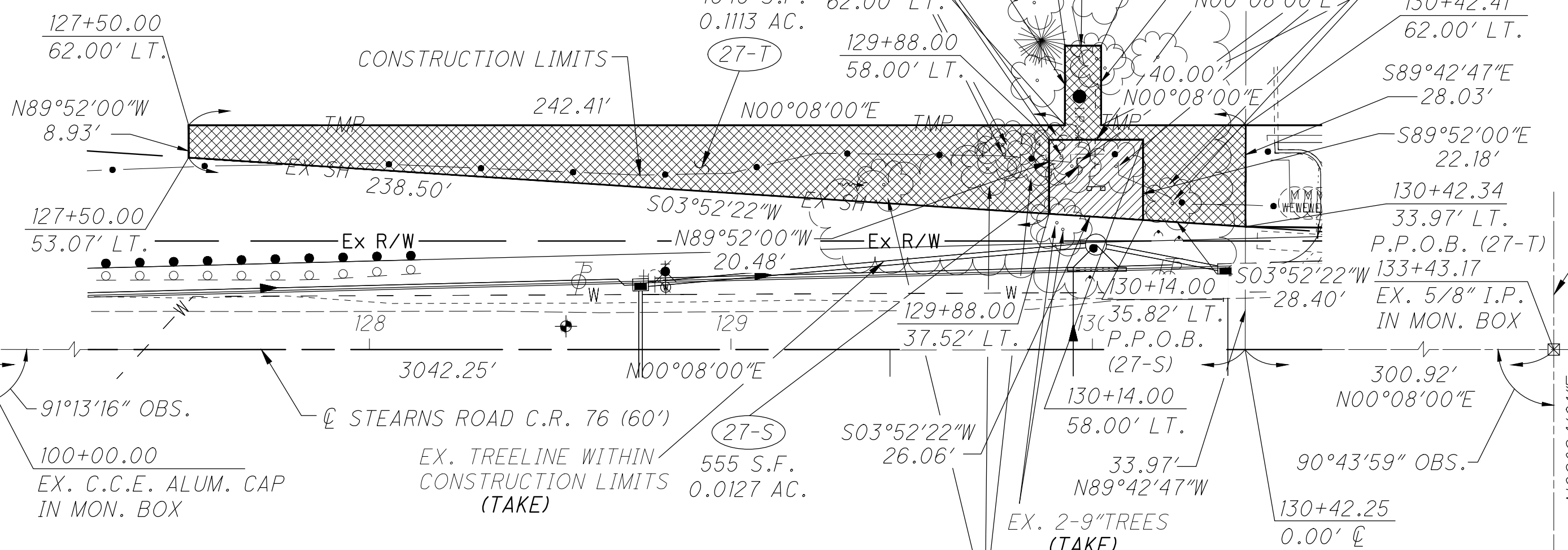

F:\Jobs\1163 - Cuy. Co. GEC - AECOM\01 - Stearns Road\Design\Row\Sheets\1163\_ Exhibits-West.dwg 28-Sep-21 10:16 AM

# M-5051 EXHIBIT "A"

SITUATED IN THE TOWNSHIP OF OLMSTED, COUNTY OF CUYAHOGA AND STATE OF OHIO AND  
KNOWN AS BEING PART OF ORIGINAL OLMSTED TOWNSHIP, LOT NO. 8, TRACT NO. 2

## PARCEL 27-S & 27-T

TEMPORARY EASEMENT AND HIGHWAY EASEMENT FOR THE PURPOSE OF  
PERFORMING THE WORK NECESSARY MAKE TO ROADWAY IMPROVEMENTS

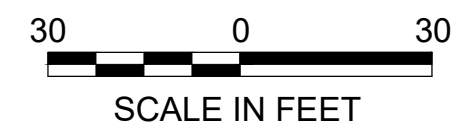

**EUTHENICS**  
8235 Mohawk Dr. | Cleveland, OH 44136

32

P.P.N. 265-04-012  
BUCKEYE INVESTMENT N.W.O. LLC.  
27133 BAGLEY ROAD  
AFN #201803190424

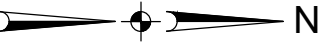

CL SCHADY ROAD (50')

CL BAGLEY ROAD C.R. 27 (60')

F:\Jobs\1163 - Cuy. Co. GEC - AECOM\01 - Stearns Road\Design\RoW\Sheets\1163\_Exhibits-West.dwg 28-Sep-21 10:16 AM

130+42.33  
33.97' LT.  
P.P.O.B.  
(32-SH)

33.97'  
N89°42'47"W

3042.25'  
N00°08'00"E

91°13'16" OBS.  
130+42.25  
0.00' CL

100+00.00  
EX. C.C.E. ALUM. CAP  
IN MON. BOX

EX. FLOWER  
BEDS  
(TAKE)

EX. BUSH &  
ROCK  
(TAKE)

EX. 2-3" TREES &  
FLOWER BEDS  
(SAVE)

EX. FLOWER BED  
(SAVE)

EX. POSTS  
(TAKE)

EX. SIGN &  
FLOWER BED  
(SAVE)

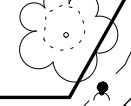
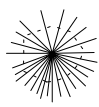

EX. FLOWER  
BEDS  
(TAKE)

133+43.17  
EX. 5/8" I.P.  
IN MON. BOX

CONC

TMP

CONC

132+76.69  
31.00' LT.

EX. FLOWER BED  
(SAVE)

TAPER

CURVE 1

CURVE 1  
R = 45.00'  
A = 9.50'  
C = 9.49'  
T = 4.77'  
C.B. = S05°55'03"E  
Δ = 12°06'05"

CL STEARNS ROAD  
C.R. 76 (60')

32-SH  
458 S.F.  
0.0105 AC.

# M-5051 EXHIBIT "A"

SITUATED IN THE TOWNSHIP OF OLMSTED, COUNTY OF CUYAHOGA AND STATE OF OHIO AND  
KNOWN AS BEING PART OF ORIGINAL OLMSTED TOWNSHIP, LOT NO. 8, TRACT NO. 2



## PARCEL 32-SH

HIGHWAY EASEMENT FOR THE PURPOSE OF PERFORMING  
THE WORK NECESSARY TO MAKE ROADWAY IMPROVEMENTS

**EUTHENICS**  
8235 Mohawk Dr. | Cleveland, OH 44136



32

P.P.N. 265-04-012  
BUCKEYE INVESTMENT N.W.O. LLC.  
27133 BAGLEY ROAD  
AFN #201803190424

COMMERCIAL

EX. BUSH &  
ROCK  
(TAKE)

EX. FLOWER BED  
(SAVE)

EX. SIGN &  
FLOWER BED  
(SAVE)

EX. FLOWER  
BEDS  
(TAKE)

EX. 2-3" TREES &  
FLOWER BEDS  
(SAVE)

EX. POSTS N00°36'12"W  
(TAKE)

130+42.41  
62.00' LT.

131+12.00  
62.00' LT.

S89°52'00"E  
12.00'

133+04.25  
75.43' LT.

133+12.25  
75.53' LT.

N89°42'47"W  
28.03'

N00°08'00"E  
69.59'

131+12.00  
50.00' LT.

5604 S.F.  
0.1287 AC.  
132+90.00  
50.00' LT.

N60°35'56"W  
29.15'

N86°31'00"W

130+42.33  
33.97' LT.

P.P.O.B. (32-T)

33.97'  
N89°42'47"W

EX R/W = 234.36'

N00°08'00"E

3042.25'  
N00°08'00"E

91°13'16" OBS.

130+42.25  
0.00' C

N88°38'44"W

100+00.00  
EX. C.C.E. ALUM. CAP  
IN MON. BOX

131

132

133

CL STEARNS ROAD  
C.R. 76 (60')

N00°08'00"E

132+76.69  
31.00' LT.

90°43'59" OBS.

133+43.17  
EX. 5/8" I.P.  
IN MON. BOX

N89°24'01"E

CURVE 1

R = 45.00'

A = 61.71'

C = 56.99'

T = 36.82'

C.B. = S51°15'22"E

Δ = 78°34'35"

EX. FLOWER  
BEDS  
(TAKE)

# M-5051 EXHIBIT "A"

SITUATED IN THE TOWNSHIP OF OLMSTED, COUNTY OF CUYAHOGA AND STATE OF OHIO AND  
KNOWN AS BEING PART OF ORIGINAL OLMSTED TOWNSHIP, LOT NO. 8, TRACT NO. 2

## PARCEL 32-T

TEMPORARY EASEMENT FOR THE PURPOSE OF PERFORMING THE  
WORK NECESSARY TO MAKE ROADWAY AND DRIVE IMPROVEMENTS

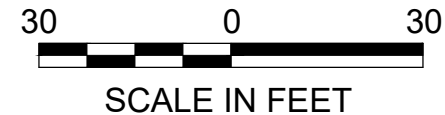

F:\Jobs\1163 - Cuy. Co. GEC - AECOM\01 - Stearns Road\Design\RoW\Sheets\1163\_Exhibits-West.dwg 28-Sep-21 10:16 AM

# M-5051 RIGHT OF WAY LEGEND SHEET CUY-STEARN'S ROAD (C.R.-76)

CUYAHOGA COUNTY  
OLMSTED TOWNSHIP  
LOT NO. 8, TRACT NO. 2 & 3  
LOT NO. 9, TRACT NO. 2

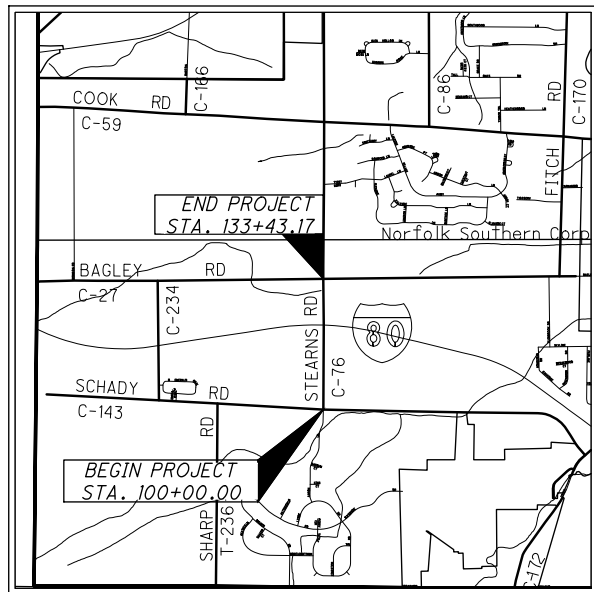

LOCATION MAP

### PROJECT DESCRIPTION

REPLACEMENT OF STEARN'S ROAD C.R. 76 PAVEMENT RECONSTRUCTION INCLUDING WIDENING, SIDEWALKS, DRAINAGE AND GRADING FROM SCHADY ROAD TO BAGLEY ROAD C.R. 27.

### PLANS PREPARED BY:

FIRM NAME : EUTHENICS INC.  
R/W DESIGNER: ALAN R. PIATAK, P.E.  
R/W REVIEWER: JOHN M. ZARANEC, P.S.  
FIELD REVIEWER: ALAN R. PIATAK, P.E.  
PRELIMINARY FIELD REVIEW DATE: 06/09/21  
TRACINGS FIELD REVIEW DATE: 09/14/21  
OWNERSHIP UPDATED BY: JOHN ZARANEC  
DATE COMPLETED: 09/16/2021  
PLAN COMPLETION DATE: 09/16/21

F:\Jobs\1163 - Cuy. Co. GEC - AECOM\01 - Stearns Road\Design\Row\1163\_RL001.dwg 27-Sep-21 10:49 AM

UTILITY OWNERS	
TYPE	NAME & ADDRESS
SANITARY SEWER & WATER	<p>CUYAHOGA COUNTY PUBLIC WORKS CUYAHOGA COUNTY ADMINISTRATIVE HEADQUARTERS DEPARTMENT OF PUBLIC WORKS 2079 EAST 9TH STREET, 5TH FLOOR CLEVELAND, OHIO 44115 CONTACT: CHRISTOPHER A. GEORGE PHONE: (216) 348-3820 cgeorge@cuyahogacounty.us</p>
	<p>NORTHEAST OHIO REGIONAL SEWER DISTRICT (NEORS) 3900 EUCLID AVENUE CLEVELAND, OHIO 44115 CONTACT: MARY MACIEJOWSKI PHONE: (216) 881-6600 EXT. 6466 maciejowskim@neorsd.org</p>
GAS	<p>COLUMBIA GAS NISOURCE / DAMAGE PREVENTION 12179 SOUTH RANGE SALEM, OHIO 44460 CONTACT: MICHELLE HARVEY PHONE: (330) 332-7052 mharvey@nisource.com</p>
	<p>CITY OF CLEVELAND DIVISION OF WATER (CWD) 1201 LAKESIDE AVENUE CLEVELAND, OHIO 44114 CONTACT: FRED ROBERTS PHONE: (216) 664-2444 EXT. 75556 fred.roberts@clevelandwater.com</p>
ELECTRIC	<p>THE ILLUMINATING CO. FIRST ENERGY (CEI) 6896 MILLER ROAD, SUITE 101 BRECKSVILLE, OHIO 44141 CONTACT: JOHN ZASSICK PHONE: (440) 546-8706 jzassick@firstenergycorp.com</p>
COMMUNICATIONS	<p>CENTURY LINK / LEVEL 3 COMMUNICATIONS 4000 CHESTER AVENUE CLEVELAND, OHIO 44103 CONTACT: DOUG HOLLOWAY PHONE: (216) 426-6010 nationalrelo@centurylink.com</p>

### INDEX OF SHEETS:

LEGEND SHEET	1
CENTERLINE PLAT	2
PROPERTY MAP	3
SUMMARY OF ADDITIONAL R/W	4-7

### LEGEND

WL = FEE SIMPLE WITH LIMITATION OF ACCESS  
WD = WARRANTY DEED  
PRW = PROPERTY RIGHT FEE SIMPLE  
SH = STANDARD HIGHWAY EASEMENT  
LA = LIMITED ACCESS EASEMENT  
T = TEMPORARY EASEMENT  
CH = CHANNEL EASEMENT  
A = AERIAL EASEMENT  
SL = SLOPE EASEMENT  
PRE = PROPERTY RIGHT EASEMENT  
S = SEWER EASEMENT

### MONUMENT LEGEND

EXISTING R/W MONUMENT BOX	IRON PIN FOUND
PROPOSED R/W MONUMENT BOX	IRON PIN FOUND W/ ID CAP
EXISTING CONCRETE MONUMENT	IRON PIN SET W/ ID CAP
PROPOSED CONCRETE MONUMENT	IRON PIPE FOUND
RAILROAD SPIKE FOUND	IRON PIPE SET
RAILROAD SPIKE SET	P.K. NAIL FOUND
	P.K. NAIL SET

NOTES: THE LOCATION OF THE UNDERGROUND UTILITIES SHOWN ON THE PLANS ARE OBTAINED FROM THE OWNER OF THE UTILITIES AS REQUIRED BY SECTION 153.64 O.R.C.

### CONVENTIONAL SYMBOLS

County Line	Ditch / Creek (Ex)
Township Line	Ditch / Creek (Pr)
Section Line	Tree Line (Ex)
Corporation Line	Ownership Hook Symbol
Fence Line (Ex) (Pr)	Property Line Symbol
Center Line	Break Line Symbol
Right of Way (Ex) (Pr)	Tree (Pr), Tree (Ex), Shrub (Ex)
Standard Highway Ease. (Ex)	Tree (Remove), Shrub (Remove)
Temporary Right of Way	Evergreen (Ex), Stump
Channel Ease. (Pr)	Evergreen (Remove), Stump (Remove)
Utility Ease. (Ex)	Wetland (Pr), Grass (Pr), Aerial Target
Railroad	Post (Ex), Mailbox (Ex), Telephone Marker (Ex)
Guardrail (Ex)	Light (Ex), Telephone Pole (Ex)
Construction Limits	Fire Hydrant (Ex), Water Meter (Ex)
Edge of Pavement (Ex)	Water Valve (Ex), Utility Valve Unknown (Ex)
Edge of Pavement (Pr)	Telephone Pole (Ex), Power Pole (Ex)
Edge of Shoulder (Ex)	Light Pole (Ex)
Edge of Shoulder (Pr)	

I, JOHN M. ZARANEC, JR., P.S. HAVE CONDUCTED A SURVEY OF THE EXISTING CONDITIONS FOR THE CUYAHOGA COUNTY DEPARTMENT OF PUBLIC WORKS FROM SEPTEMBER 2020 TO JUNE 2021. THE RESULTS OF THAT SURVEY ARE CONTAINED HEREIN.

THE HORIZONTAL COORDINATES EXPRESSED HEREIN ARE BASED ON THE OHIO STATE PLANE COORDINATES SYSTEM NORTH ZONE ON NAD 83 (2011) DATUM. THE PROJECT COORDINATES (US SURVEY FEET) ARE RELATIVE TO STATE PLANE GRID COORDINATES (METERS OR US SURVEY FEET) BY A PROJECT COMBINED FACTOR OF 1.0000806512.

AS A PART OF THIS PROJECT, I HAVE ESTABLISHED THE LOCATIONS OF THE EXISTING PROPERTY LINES AND THE EXISTING CENTERLINE OF RIGHT OF WAY BASED ON RECORD INFORMATION FOR PROPERTY EASEMENTS CONTAINED HEREIN.

ALL OF MY WORK CONTAINED HEREIN WAS CONDUCTED IN ACCORDANCE WITH OHIO ADMINISTRATIVE CODE 4733-37 COMMONLY KNOWN AS "MINIMUM STANDARDS FOR BOUNDARY SURVEYS IN THE STATE OF OHIO" UNLESS NOTED.

THE WORDS I AND MY AS USED HEREIN ARE TO MEAN EITHER MYSELF OR SOMEONE WORKING UNDER MY DIRECT SUPERVISION.

JOHN M. ZARANEC, JR. 09/16/21  
PROFESSIONAL LAND SURVEYOR NO. 7126 DATE

### STRUCTURE KEY

	RESIDENTIAL
	COMMERCIAL
	OUT-BUILDING

FEDERAL PROJECT NO. PID NO. CALCULATED TOP CHECKED JNZ CUY-STEARN'S ROAD C.R.-76 RIGHT OF WAY LEGEND SHEET 1207

# M-5051

CUYAHOGA COUNTY  
OLMSTED TOWNSHIP  
LOT NO. 8, TRACT NO. 2 & 3  
LOT NO. 9, TRACT NO. 2

BASIS FOR BEARING :

BEARINGS SHOWN HEREIN ARE BASED ON GRID NORTH OF THE OHIO STATE PLANE COORDINATE SYSTEM, NORTH ZONE, NAD 83 (2011) ADJUSTMENT REFERENCE FRAME DERIVED FROM VRS OBSERVATIONS OF THE PROJECT CONTROL MONUMENTS IN SEPTEMBER 2020.



PID NO.

R/W DESIGNER  
TDP  
R/W REVIEWER  
JMZ

STATE JOB NO.

CNTY. I.D. 1207

CENTERLINE PLAT

CUY-STEARN'S ROAD  
C.R.-76

2/7



### ELEVATION DATUM AND SURVEYING PARAMETERS

USE THE FOLLOWING VERTICAL AND HORIZONTAL POSITIONING PARAMETERS FOR ALL SURVEYING:

HORIZONTAL COORDINATES ARE TO BE PROJECT GROUND COORDINATES EXPRESSED IN U.S. SURVEY FEET BASED ON THE OHIO STATE PLANE COORDINATE SYSTEM, NORTH ZONE AND REFERENCE THE NORTH AMERICAN DATUM OF 1983 (NAD83) AND THE 2011 CORS ADJUSTMENT. THE COMBINED SCALE FACTOR IS TO BE INCLUDED WITH THE PROJECT CONTROL INFORMATION FOR THE PROJECT.

VERTICAL CONTROL IS TO BE BASED ON THE NORTH AMERICAN VERTICAL DATUM OF 1988 (NAVD 88).

#### VERTICAL POSITIONING

ORTHOMETRIC HEIGHT DATUM: NAVD 88  
GEOID: 12B

#### HORIZONTAL POSITIONING

REFERENCE FRAME: NAD 83 (CONUS)(MOL)  
ELLIPSOID: GRS 80  
MAP PROJECTION: LAMBERT CONFORMAL CONIC  
COORDINATE SYSTEM: OHIO STATE PLANE - NORTH ZONE  
COMBINED SCALE FACTOR: 1.0000806512 (GRID TO GROUND)  
ORIGIN OF SYSTEM: (0,0)

I, JOHN M. ZARANEC, JR., P.S. HAVE CONDUCTED A SURVEY OF THE EXISTING CONDITIONS FOR THE CUYAHOGA COUNTY DEPARTMENT OF PUBLIC WORKS FROM SEPTEMBER 2020 TO JUNE 2021. THE RESULTS OF THAT SURVEY ARE CONTAINED HEREIN.

THE HORIZONTAL COORDINATES EXPRESSED HEREIN ARE BASED ON THE OHIO STATE PLANE COORDINATES SYSTEM NORTH ZONE ON NAD 83 (2011) DATUM. THE PROJECT COORDINATES (US SURVEY FEET) ARE RELATIVE TO STATE PLANE GRID COORDINATES (METERS OR US SURVEY FEET) BY A PROJECT COMBINED FACTOR OF 1.0000806512.

AS A PART OF THIS PROJECT, I HAVE ESTABLISHED THE LOCATIONS OF THE EXISTING PROPERTY LINES AND THE EXISTING CENTERLINE OF RIGHT OF WAY BASED ON RECORD INFORMATION FOR PROPERTY EASEMENTS CONTAINED HEREIN.

ALL OF MY WORK CONTAINED HEREIN WAS CONDUCTED IN ACCORDANCE WITH OHIO ADMINISTRATIVE CODE 4733-37 COMMONLY KNOWN AS "MINIMUM STANDARDS FOR BOUNDARY SURVEYS IN THE STATE OF OHIO" UNLESS NOTED.

THE WORDS I AND MY AS USED HEREIN ARE TO MEAN EITHER MYSELF OR SOMEONE WORKING UNDER MY DIRECT SUPERVISION.

JOHN M. ZARANEC, JR. 09/16/21  
PROFESSIONAL LAND SURVEYOR NO. 7126 DATE

REV. BY	DATE	DESCRIPTION

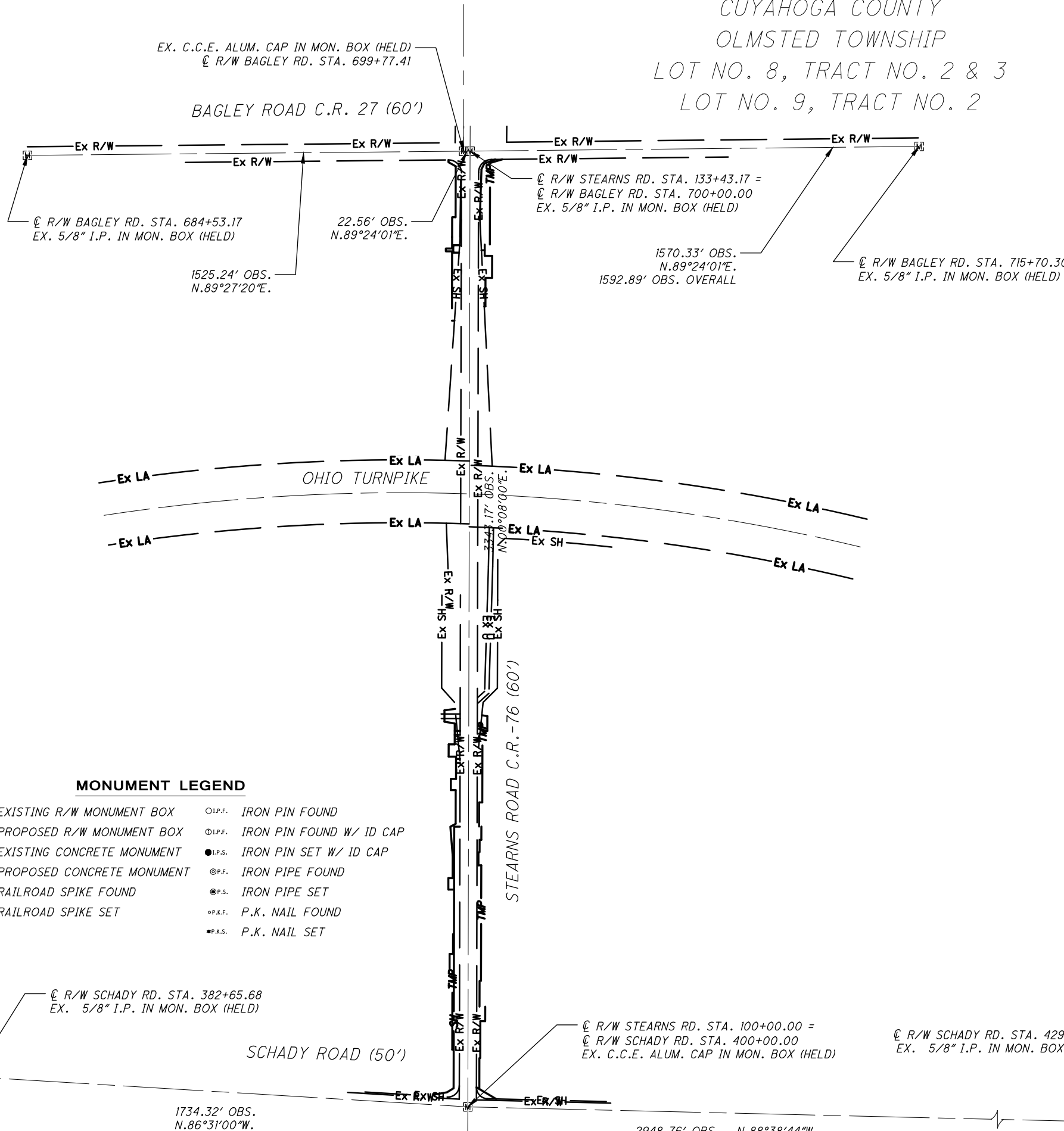

### MONUMENT LEGEND

- |   |                            |          |                          |
|---|----------------------------|----------|--------------------------|
| ☐ | EXISTING R/W MONUMENT BOX  | ○ I.P.F. | IRON PIN FOUND           |
| ▣ | PROPOSED R/W MONUMENT BOX  | ⊙ I.P.F. | IRON PIN FOUND W/ ID CAP |
| ⊙ | EXISTING CONCRETE MONUMENT | ● I.P.S. | IRON PIN SET W/ ID CAP   |
| ● | PROPOSED CONCRETE MONUMENT | ⊙ I.P.F. | IRON PIPE FOUND          |
| ⚡ | RAILROAD SPIKE FOUND       | ⊙ I.P.S. | IRON PIPE SET            |
| ★ | RAILROAD SPIKE SET         | ⊙ P.K.F. | P.K. NAIL FOUND          |
|   |                            | ● P.K.S. | P.K. NAIL SET            |

F:\Jobs\1163 - Cuy. Co. GEC - AECOM\01 - Stearns Road\Design\RoW\1163\_RC001.dwg 27-Sep-21 10:49 AM

# M-5051

CUYAHOGA COUNTY  
 OLMSTED TOWNSHIP  
 LOT NO. 8, TRACT NO. 2 & 3  
 LOT NO. 9, TRACT NO. 2

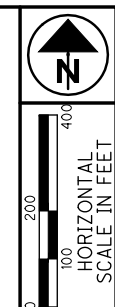

PID NO.

R/W DESIGNER  
 TDP  
 R/W REVIEWER  
 JMJ

STATE JOB NO.  
 1207

PROPERTY MAP

CUY-STEARN'S ROAD  
 C.R.-76

3/7

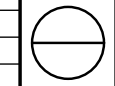

REV. BY	DATE	DESCRIPTION

F:\Jobs\1163 - Cuy. Co. GEC - AECOM\01 - Stearns Road\Design\Row\1163\_RM001.dwg 27-Sep-21 10:49 AM

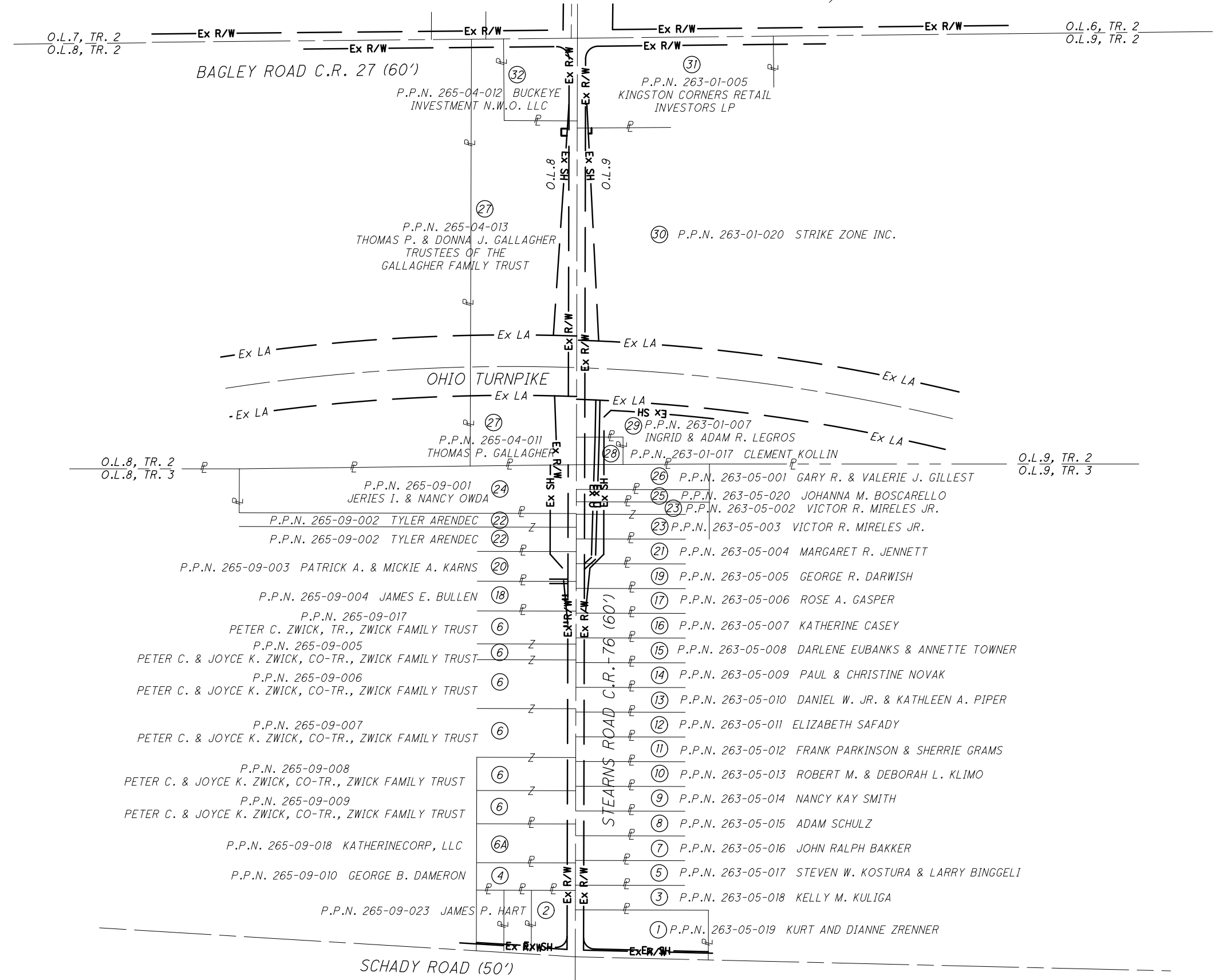







TOTAL NUMBER OF :  
 35 OWNERSHIPS 10 TOTAL EASEMENTS  
 41 PARCELS 0 OWNERSHIP W/STRUCTURES INVOLVED

NET RESIDUE = RECORD AREA - TOTAL PRO - NET TAKE

GRANTEE :  
 ALL RIGHT OF WAY ACQUIRED IN THE NAME OF  
 COUNTY OF CUYAHOGA, OHIO  
 UNLESS OTHERWISE SHOWN.

ALL AREAS IN ACRES

PARCEL NO.	OWNER	SHEET NO.	OWNERS RECORD	AUDITOR'S PARCEL	RECORD AREA	TOTAL P.R.O.	GROSS TAKE	P.R.O. IN TAKE	NET TAKE	STRUC-TURE	NET RESIDUE		TYPE FUND	REMARKS	AS ACQUIRED	
											LEFT	RIGHT			BOOK	PAGE
17-T	ROSE A. GASPER		AFN #200910070109	263-05-006	0.930	0.0173	0.0300		0.0300					DRIVEWAY AND GRADING		
18-T	JAMES E. BULLEN		VOL. 86-1165, PG. 12 O.R.	265-09-004	3.050	0.0248	0.0456		0.0456					DRIVEWAY AND GRADING		
19-T	GEORGE R. DARWISH		AFN #201905160486	263-05-005	0.920	0.0380	0.0133		0.0133					DRIVEWAY AND GRADING		
20-T	PATRICK A. & MICKIE A. KARNS		VOL. 97-9805, PG. 33 O.R.	265-09-003	3.040	0.0826	0.0206		0.0206					DRIVEWAY AND GRADING		
21	MARGARET R. JENNETT		VOL. 97-627, PG. 50 O.R.	263-05-004	0.820	0.1312										
22-1	TYLER ARENDEC		AFN #201710180545	265-09-002	3.810	0.1325										
22-2	TYLER ARENDEC		AFN #201710180545	265-09-002	3.810	0.0746										
23-2	VICTOR R. MIRELES JR.		AFN #201812270339	263-05-003	0.820	0.1446										
23-1	VICTOR R. MIRELES JR.		AFN #201812270339	263-05-002	0.360	0.0725										
24	JERIES I. & NANCY OWDA		AFN #201607150525	265-09-001	5.000	0.2637										
25	JOHANNA M. BOSCARIELLO		AFN #201810110581	263-05-020	0.400	0.0723										
26	GARY R. & VALERIE J. GILLEST		VOL. 91-2632, PG. 18 O.R.	263-05-001	0.820	0.1454										

NOTES:  
 UNDER NO CIRCUMSTANCES ARE TEMPORARY EASEMENTS TO BE USED FOR STORAGE OF MATERIAL OR EQUIPMENT BY THE CONTRACTOR UNLESS NOTED OTHERWISE.  
 ALL TEMPORARY PARCELS TO BE OF 12 MONTHS DURATION.  
 ALL AREAS ARE IN ACRES UNLESS NOTED OTHERWISE  
 RECORD AREA TAKEN FROM CUYAHOGA COUNTY AUDITOR GIS PROPERTY DATA.

LEGEND:  
 T: TEMPORARY EASEMENT  
 SH: STANDARD HIGHWAY EASEMENT  
 S: STORM SEWER EASEMENT  
 AFN = AUDITOR FILE NUMBER  
 O.R.= OFFICIAL RECORD  
 C.C.D.R. = CUYAHOGA COUNTY DEED RECORD  
 (c)= VALUE CALCULATED FROM CUYAHOGA COUNTY GIS  
 (n)= SEE NOTE IN REMARKS COLUMN  
 \*= RIGHT OF WAY ENCROACHMENT

REV. BY	DATE	DESCRIPTION

F:\Jobs\1163 - Cuy. Co. GEC - AECOM\01 - Stearns Road\Design\Row\1163\_RS001.dwg 27-Sep-21 10:49 AM

FEDERAL PROJECT NO.  
 PID NO.  
 STATE JOB NO.  
 R/W DESIGNER TDP  
 R/W REVIEWER JMZ  
 CNTY. I.D. 1207  
**SUMMARY OF ADDITIONAL RIGHT OF WAY**  
**CUY-STEARN'S ROAD C.R.-76**  
 6/7

TOTAL NUMBER OF :  
 35 OWNERSHIPS 10 TOTAL EASEMENTS  
 41 PARCELS 0 OWNERSHIP W/STRUCTURES INVOLVED

NET RESIDUE = RECORD AREA - TOTAL PRO - NET TAKE

GRANTEE :  
 ALL RIGHT OF WAY ACQUIRED IN THE NAME OF  
 COUNTY OF CUYAHOGA, OHIO  
 UNLESS OTHERWISE SHOWN.

ALL AREAS IN ACRES

PARCEL NO.	OWNER	SHEET NO.	OWNERS RECORD	AUDITOR'S PARCEL	RECORD AREA	TOTAL P.R.O.	GROSS TAKE	P.R.O. IN TAKE	NET TAKE	STRUC-TURE	NET RESIDUE		TYPE FUND	REMARKS	AS ACQUIRED	
											LEFT	RIGHT			BOOK	PAGE
27	THOMAS P. GALLAGHER		AFN #200401280294	265-04-011	1.900	0										
27-S	THOMAS P. & DONNA J. GALLAGHER TRUSTEES OF THE GALLAGHER FAMILY TRUST		AFN #201502120315	265-04-013	7.751	0.5293	0.0127		0.0127		7.209			GRADING AND STORM SEWER		
27-T	THOMAS P. & DONNA J. GALLAGHER TRUSTEES OF THE GALLAGHER FAMILY TRUST		AFN #201502120315	265-04-013	7.751	0.5293	0.1113		0.1113					GRADING		
28	CLEMENT KOLLIN		VOL. 93-8559, PG. 55 O.R.	263-01-017	0.321	0.1607										
29	INGRID & ADAM R. LEGROS		AFN #202006160514	263-01-007	0.816	0.3408										
30-S	STRIKE ZONE INC.		VOL. 87-1853, PG. 36 O.R.	263-01-020	11.995	0.5284	0.0055		0.0055		11.4611			GRADING AND STORM SEWER		
30-T	STRIKE ZONE INC.		VOL. 87-1853, PG. 36 O.R.	263-01-020	11.995	0.5284	0.0813		0.0813					DRIVEWAY AND GRADING		
31-SH	KINGSTON CORNERS RETAIL INVESTORS LP		AFN #200410130540	263-01-005	4.899	0.0144	0.0390		0.0390		4.8456			SIDEWALK, DRIVEWAY AND GRADING		
31-T							0.2158		0.2158							
32-SH	BUCKEYE INVESTMENT N.W.O. LLC		AFN #201803190424	265-04-012	1.834	0.0028	0.0105		0.0105		1.8207			SIDEWALK, DRIVEWAY AND GRADING		
32-T							0.1287		0.1287							

NOTES:  
 UNDER NO CIRCUMSTANCES ARE TEMPORARY EASEMENTS TO BE USED FOR STORAGE OF MATERIAL OR EQUIPMENT BY THE CONTRACTOR UNLESS NOTED OTHERWISE.  
 ALL TEMPORARY PARCELS TO BE OF 12 MONTHS DURATION.  
 ALL AREAS ARE IN ACRES UNLESS NOTED OTHERWISE  
 RECORD AREA TAKEN FROM CUYAHOGA COUNTY AUDITOR GIS PROPERTY DATA.

LEGEND:  
 T: TEMPORARY EASEMENT  
 SH: STANDARD HIGHWAY EASEMENT  
 S: STORM SEWER EASEMENT  
 AFN = AUDITOR FILE NUMBER  
 O.R.= OFFICIAL RECORD  
 C.C.D.R. = CUYAHOGA COUNTY DEED RECORD  
 (c)= VALUE CALCULATED FROM CUYAHOGA COUNTY GIS  
 (n)= SEE NOTE IN REMARKS COLUMN  
 \*= RIGHT OF WAY ENCROACHMENT

REV. BY	DATE	DESCRIPTION

F:\Jobs\1163 - Cuy. Co. GEC - AECOM\01 - Stearns Road\Design\Row\1163\_RS001.dwg 27-Sep-21 10:50 AM

FEDERAL PROJECT NO.  
 PID NO.  
 STATE JOB NO.  
 R/W DESIGNER TDP  
 R/W REVIEWER JMZ  
 CNTY. I.D. 1207  
**SUMMARY OF ADDITIONAL RIGHT OF WAY**  
**CUY-STEARN'S ROAD C.R.-76**

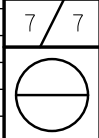

# County Council of Cuyahoga County, Ohio

## Resolution No. R2021-0255

Sponsored by: <b>County Executive Budish/Fiscal Department</b>	<b>A Resolution</b> authorizing a Contract with Clark, Schaefer, Hackett & Co., in the amount not-to-exceed \$2,320,000.00 for annual audits for Calendar Years 2021-2025 for the period 9/30/2021 – 12/31/2026; authorizing the County Executive to execute Contract No. 1725 and all other documents consistent with this Resolution; and declaring the necessity that this Resolution become immediately effective.
--	--

WHEREAS, the County Executive/Fiscal Department has authorized Contract No. 1725 (RQ1725) with Clark, Schaefer, Hackett & Co., in the amount not-to-exceed \$2,320,000.00 for annual audits for Calendar Years 2021-2025 for the period 9/30/2021 – 12/31/2026; and

WHEREAS, the annual audit is required per Ohio Revised Code Section 117.11; and

WHEREAS, this project is funded 100% by the General Fund; and

WHEREAS, it is necessary that this Resolution become immediately effective in order that critical services provided by Cuyahoga County can continue and to provide for the usual, daily operation of a County entity.

**NOW, THEREFORE, BE IT RESOLVED BY THE COUNTY COUNCIL OF CUYAHOGA COUNTY, OHIO:**

**SECTION 1.** That the Cuyahoga County Council hereby authorizes Contract No. 1725 (RQ1725) with Clark, Schaefer, Hackett & Co., in the amount not-to-exceed \$2,320,000.00 for annual audits for Calendar Years 2021-2025 for the period 9/30/2021 – 12/31/2026.

**SECTION 2.** That the County Executive is authorized to execute the contract and all other documents consistent with this Resolution.

**SECTION 3.** It is necessary that this Resolution become immediately effective for the usual daily operation of the County; the preservation of public peace, health and safety in the County; and any additional reasons set forth in the preamble. Provided that this Resolution receives the affirmative vote of at least eight members



Title: Fiscal Department; (RQ#) 2021-2025 audit periods – Clark, Schaefer, Hackett & Co.;5-year contract to audit Cuyahoga County

#### Scope of Work Summary

Fiscal Department requesting approval of a contract with Clark, Schaefer, Hackett & Co. for the anticipated cost not-to-exceed \$2,320,000.00 for the 5-year period covering the 2021 – 2025 audit periods.

This is not a new project but a new vendor – prior year audits performed by the State Auditor’s Office.

The anticipated start-completion dates are estimated to be 9/30/21 through 12/31/26 for work/invoicing purposes with the contract covering the fiscal year audits from the periods 1/1/21 – 12/31/25.

The primary goals of the project are (list 2 to 3 goals).

The County receives a clean audit opinion. The County has no significant audit findings.

The Annual audit is required per ORC 117.11.

#### Procurement

The procurement method for this project was government directed contract – ie selected by the State of Ohio Auditor’s Office. The total value of the 5-year contract is ~~\$2,230,000.00~~ **\$2,320,000.00**.

#### Contractor and Project Information

Clark, Schaefer, Hackett & Co  
Attention Kerry Roe  
1422 Euclid Ave. Suite 708  
Cleveland, Ohio 44115

#### Project Status and Planning

The project/annual audit occurs annually over the 5-year term of the contract.

#### Funding

The project is funded 100% by the General Fund.

The schedule of payments is by invoice

## Office of Procurement and Diversity – Required Documents Checklist

Upload as “word” document in OnBase Document Management

Infor/Lawson RQ#:	
Buyspeed RQ# (if applicable):	
Infor/Lawson PO# Code (if applicable):	
CM Contract#	1725

	<b>Department initials</b>	<b>Clerk of the Board</b>
Briefing Memo	MZ	<input type="checkbox"/>

Late Submittal Required:	Yes <input type="checkbox"/>	No <input checked="" type="checkbox"/>
Why is the contract being submitted late?		
What is being done to prevent this from reoccurring?		

TAC Required:	Yes <input type="checkbox"/>	No <input checked="" type="checkbox"/>
---------------	------------------------------	--

❖ **UNLESS THE DOCUMENT HAS CONVERTED OVER FROM THE EVENT THEN THE BELOW LISTED DOCUMENTS MUST BE UPLOADED TO THE PO IN PO 20 FOR REVIEW BY CONTRACTING AUTHORITY**

OTHER THAN FULL AND OPEN COMPETITION					
RFP Exemptions (Contract)					
				Department initials	OPD
Justification Form				MZ	OK (revised signed uploaded 9/15/2021)
IG#	21-0213-reg ex 12/31/25			MZ	OK
Annual Non-Competitive Bid Contract Statement	Date: 6/22/21	N/A per legal		MZ	No doc attached (per Law Department)
Debarment/Suspension Verified	Date:	7/7/2021		JP	OK
Auditor’s Finding	Date:	7/7/2021		JP	OK
Vendor’s Submission				MZ	OK
W-9 – if required	Tax ID#	31-0800053	Date: <del>7/14/21</del> 7/2/2021	MZ	OK
Independent Contractor (I.C.) Requirement			Date: 7/14/21	MZ	OK
Agreement/Contract and Exhibits – Their agreement/legal				MZ	Approved by Law Department
Cover - Master contracts only					OK
Contract Evaluation – if required					N/A
Matrix Law Screen shot (documenting approval of Contract; COI and Workers’ Compensation Certificate)				MZ	OK
COI - <i>*To be reviewed by the Department of Law. *OPD Buyer to check for attachment; not for compliance.</i>				N/A per Legal	No doc attached
Workers’ Compensation Insurance - <i>*To be reviewed by the Department of Law. *OPD Buyer to check for attachment; not for compliance.</i>				N/A per legal	No doc attached
Checklist Verification				MZ	Reviewed



## Office of Procurement and Diversity – Required Documents Checklist

Upload as “word” document in OnBase Document Management

Other documentation may be required depending upon your specific item

Glossary of Terms at: <https://intranet.cuyahoga.cc/policies-procedures/procurement-information>

### Accounting Units – REVISED 10/6/2021

Time Period	Accounting Unit	Account Number	Sub Account	Dollar Amount
9/30/21 – 12/31/21	FS100110	55200		\$0
1/1/22 – 12/31/22	FS100110	55200		\$440,000
1/1/23 – 12/31/23	FS100110	55200		\$448,000
1/1/24 – 12/31/24	FS100110	55200		\$460,000
1/1/25 – 12/31/25	FS100110	55200		\$476,000
1/1/26 – 12/31/26	FS100110	55200		\$496,000
			<b>TOTAL</b>	2,320,000.00

### Accounting Units – REVISED 9/15/2021

Time Period	Accounting Unit	Account Number	Sub Account	Dollar Amount
<del>1/1/22 – 12/31/22</del>	<del>FS100110</del>	<del>55200</del>	-	\$440,000
<del>1/1/23 – 12/31/23</del>	<del>FS100110</del>	<del>55200</del>	-	<del>\$448,000</del>
1/1/24 – 12/31/24	FS100110	55200		\$460,000
1/1/25 – 12/31/25	FS100110	55200		\$476,000
1/1/26 – 12/31/26	FS100110	55200		\$496,000
	-	-	-	-
			<b>TOTAL</b>	<del>2,320,000.00</del>

### Accounting Units

Time Period	Accounting Unit	Account Number	Sub Account	Dollar Amount
1/1/21 – 12/31/25	FS100110	55200	-	<b>\$2,320,000</b>
<b>Charges for budget spread – see bottom</b>	-	-	-	-

2 | Page

Revised 9/11/2020

## Office of Procurement and Diversity – Required Documents Checklist

Upload as “word” document in OnBase Document Management

	-	-	-
	-	-	<b>TOTAL</b>
			2,320,000.00

<b>Current Contract History:</b> CE/AG# (if applicable)	
<b>Infor/Lawson PO# Code:</b>	
<b>BuySpeed or Lawson RQ#</b> (if applicable)	

	Original Amount	Amendment Amount	Original Time Period/Amended End Date	Approval Date	Approval #
<b>Original Amount</b>	<b>\$2,320,000.00</b>		<b>Periods covered</b> 1/1/21-12/31/25		
<b>Prior Amendment Amounts</b> (list separately)		\$			
		\$			
		\$			
<b>Pending Amendment</b>		\$			
<b>Total Amendments</b>		\$			
<b>Total Contract Amount</b>	<b>\$2,320,000.00</b>	\$			

### OPD Use Only:

Prior Resolutions:	BC2021-435
PO#:	1725
Vendor Name:	Clark, Schaefer, Hackett & Co.
ftp:	9/30/2021-12/31/2026
Amount:	\$2,320,000.00mm
History/CE:	OK
EL:	Needs WET
Procurement Notes:	10/7/2021: Agreement attached does not have any amount. Agreement attached is MOA, not an actual contract; however, Law Department has approved for the contract term and amount submitted. If Clerks for the BOC and Council have any questions, they should be directed to the Fiscal Office. Documentation is in the Electronic Folder. PA sending to Interim Dept of Purchasing Director for approval in order to move the item forward. 9/23/2021: Vendor Agreement tab - Enter EXMT as the PO code under header type specific; create GL commitment and complete distribution spread for the encumbrance line; The Budget spread information provided on the original and revised checklist does

# Office of Procurement and Diversity – Required Documents Checklist

## Upload as “word” document in OnBase Document Management

not match the information submitted on the line – 2021 encumbrance entered (budget spread from checklist begins 1/1/2022). This information needs to match in order to create a correct contract cover and that the encumbrances per year are correct.  
8/27/2021: Contract and Line effective date listed as 1/1/2021 – does not match information submitted in other documentation. The Budget spread information provided on the checklist does not match the information submitted on the line (budget spread from checklist begins 1/1/2022). Submit a REVISED checklist with the Accounting Units table completed with the contract cover information, insert rows as necessary; Justification needs revised – Page 2 is not completed; Question #1 does not list amount or time period of contract and must have approved signature authority to sign;  
8/4/2021: Agreement attached does not have any amount. Agreement attached is MOA, not an actual contract, no procurement. Attach the actual contract once MOA is approved & executed and submit for contract approval at that time, per information in the contract with all required, valid documentation from the time of the re-submission into the review queue.

### OPD Buyer approval:

The screenshot shows a web browser window with the URL <https://ccprod.cloud.infor.com...>. The page title is "Contract Mgmt & Sourcing" and the main heading is "Update Contract Line Distribution".

Contract Group: CUYA CUYAHOGA COUNTY ENTERPRISE

Contract: 1725 Clark Schaeffer & Hackett & Co. Fiscal Audit - 5yr

Supplier: 3750 Clark Schaeffer Hackett & Co. Contract Status: Released

Line: 2 2021 Funds No

Contract Line Distribution: 1

Distribution Code	Company	Distribution Code
10		

Distribution Company	Accounting Unit	Amount
10	PS100110	\$5200.00

Activity: [View Summary](#)

Billing Category: [View Summary](#)

Percent	Distribution Amount
100.00%	440,000.00

Page 3 of 4 540 words

# Office of Procurement and Diversity – Required Documents Checklist

## Upload as “word” document in OnBase Document Management

Contract #1725

Contract Group: CUVA  
Contract: 1725  
Working Contract ID: 1725  
Description: Clark Schaefer & Hackett & Co. Fiscal Audit - 5yr

Supplier: Clark Schaefer Hackett & Co.  
Supplier Contact: Kerry Roe  
Status: Released

Service Contract Lines

Line Number	Description	UOM	Base Cost	Create Agreement Line
2	2021 Furlies	EA	440,000.00	Yes

### Budget Spread –

1/1/22 – 12/31/22 - \$440,000.00 for 2021 audit  
1/1/23 – 12/31/23 - \$448,000.00 for 2022 audit  
1/1/24 – 12/31/24 – \$460,000.00 for 2023 audit  
1/1/25 – 12/31/25 – \$476,000.00 for 2024 audit  
1/1/26 – 12/31/26 – \$496,000.00 for 2025 audit

**Total - \$2,320,000.00**

# County Council of Cuyahoga County, Ohio

## Resolution No. R2021-0256

Sponsored by: <b>County Executive Budish/County Treasurer</b>	<b>A Resolution</b> designating agreements with various eligible institutions, as public depositories of active and interim funds of Cuyahoga County in the total deposit limit amount not-to-exceed \$1,215,000,000.00 for the period 8/1/2021 – 4/1/2024, in accordance with the Uniform Depository Act of Ohio; authorizing the County Executive and/or Treasurer to execute the agreements and all other documents consistent with said award and this Resolution and declaring the necessity that this Resolution become immediately effective.
---	--

WHEREAS, the County Executive/County Treasurer has recommended designating agreements with various eligible institutions, as public depositories of active and interim funds of Cuyahoga County in the total deposit limit amount not-to-exceed \$1,215,000,000.00 for the period 8/1/2021 – 4/1/2024, in accordance with the Uniform Depository Act of Ohio as follows:

- a) Dollar Bank, Federal Savings Bank in the deposit limit amount not-to-exceed \$50,000,000.00
- b) First Federal Savings and Loan Associations of Lakewood in the deposit limit amount not-to-exceed \$5,000,000.00
- c) The Huntington National Bank in the deposit limit amount not-to-exceed \$200,000,000.00
- d) JP Morgan Chase Bank, N.A. in the deposit limit amount not-to-exceed \$200,000,000.00
- e) KeyBank National Association in the deposit limit amount not-to-exceed \$700,000,000.00
- f) PNC Bank in the deposit limit amount not-to-exceed \$10,000,000.00
- g) U.S. Bank National Association in the deposit limit amount not-to-exceed \$50,000,000.00

WHEREAS, the primary goal of this project is to designate eligible institutions as public depositories of active and interim funds of Cuyahoga County and to enter into various bank depository agreements for said deposits of public funds, in accordance to the Uniform Depository Act of Ohio; and

WHEREAS, it is necessary that this Resolution become immediately effective in order that critical services provided by Cuyahoga County can continue and to provide for the usual, daily operation of a County entity.

**NOW, THEREFORE, BE IT RESOLVED BY THE COUNTY COUNCIL OF CUYAHOGA COUNTY, OHIO:**

**SECTION 1.** That the Cuyahoga County Council hereby designating agreements with various eligible institutions, as public depositories of active and interim funds of Cuyahoga County in the total deposit limit amount not-to-exceed \$1,215,000,000.00 for the period 8/1/2021 – 4/1/2024, in accordance with the Uniform Depository Act of Ohio as follows:

- a) Dollar Bank, Federal Savings Bank in the deposit limit amount not-to-exceed \$50,000,000.00
- b) First Federal Savings and Loan Associations of Lakewood in the deposit limit amount not-to-exceed \$5,000,000.00
- c) The Huntington National Bank in the deposit limit amount not-to-exceed \$200,000,000.00
- d) JP Morgan Chase Bank, N.A. in the deposit limit amount not-to-exceed \$200,000,000.00
- e) KeyBank National Association in the deposit limit amount not-to-exceed \$700,000,000.00
- f) PNC Bank in the deposit limit amount not-to-exceed \$10,000,000.00
- g) U.S. Bank National Association in the deposit limit amount not-to-exceed \$50,000,000.00

**SECTION 2.** To the extent an exemption for anything herein is needed, it is hereby granted.

**SECTION 3.** That the County Executive and /or Treasurer is authorized to execute the agreements and all other documents consistent with this Resolution.

**SECTION 4.** It is necessary that this Resolution become immediately effective for the usual daily operation of the County; the preservation of public peace, health or safety in the County; and for any additional reasons set forth in the preamble. Provided that this Resolution receives the affirmative vote of at least eight members of Council, it shall take effect and be in force immediately upon the earliest occurrence of any of the following: (1) its approval by the County Executive through signature, (2) the expiration of the time during which it may be disapproved by the County Executive under Section 3.10(6) of the Cuyahoga County Charter, or (3) its passage by at least eight members of Council after disapproval pursuant to Section 3.10(7) of the Cuyahoga County Charter. Otherwise, it shall take effect and be in force from and after the earliest period allowed by law.

**SECTION 5.** It is found and determined that all formal actions of this Council relating to the adoption of this Resolution were adopted in an open meeting of the



Title: Cuyahoga County Treasury; RQ# n/a; 2021; Various Vendors/Banking Institutions; Depository Agreements

#### Scope of Work Summary

Cuyahoga County Treasury requesting approval of seven depository agreements with various lending institutions for the anticipated cost \$ 0.00.

The anticipated start-completion dates are 8/1/2021- 4/1/2024.

The primary goals of the project are (list 2 to 3 goals).

- The Depository Agreement covers a designated period of time and allows the bank to stipulate the maximum amount of deposits they are willing to hold of ours.
- A depository agreement must be on file with every bank that the County currently does business with but is also extended to other local banks in the event that, at some point in time during the future, we decide to establish a depository agreement with them.
- The depository agreement is not a contract that agrees to fees or services. It serves singularly as a place holder for the opportunity to do business in the future.

The County invites all local banks to sign a Depository Agreement for Active Funds, as defined by ORC 135.01.

#### Procurement

There was no procurement method as this is a non-monetary agreement and is a place holder. The total value of the agreements is \$0.00.

#### Contractor and Project Information

US Bank National Association  
800 Nicollet Mall  
Minneapolis MN 55402

First Federal Savings & Loan Association of Lakewood  
14806 Detroit Avenue  
Lakewood OH 44107

KeyBank National Association  
127 Public Square  
Cleveland OH 44114

The Huntington National Bank  
41 South High Street HC0910  
Columbus OH 43215



PNC Bank National Association  
300 Fifth Avenue  
Pittsburgh PA 15222  
Dollar Bank, Federal Savings Bank  
20 Stanwix Street  
Pittsburgh PA 15222

JPMorgan Chase Bank, NA  
1111 Polaris Pkwy  
Columbus OH 43240

US Bank – Jeffrey M Spetrino, Senior Vice President  
First Federal Lakewood – Alix Kaufmann, Vice President  
KeyBank – Charles Wise, Vice President  
Huntington National Bank – Maureen Shildwachter, Vice President  
PNC Bank National Association – Kevin Grobelny  
Dollar Bank – Grif King, Vice President  
JP Morgan Chase Bank – Zubair Ahmed

#### Project Status and Planning

The agreements are signed approximately every three years – these agreements will all expire on 4/1/2024.

Time line is 8/1/2021 to 4/1/2024. Submission of the depository agreements was delayed due to required additional documents that needed to be obtained from the lenders.

#### Funding

The project is non-monetary and no funds will be encumbered.

# County Council of Cuyahoga County, Ohio

## Resolution No. R2021-0257

<b>Sponsored by: County Executive Budish/Department of Health and Human Services/Division of Senior and Adult Services</b>	<b>A Resolution</b> authorizing an amendment to Contract No. 256 with Lutheran Metropolitan Ministry for adult guardianship services for the period 1/1/2021 – 12/31/2021 to extend the time period to 12/31/2022 and for additional funds in the amount not-to-exceed \$605,285.00; authorizing the County Executive to execute the amendment and all other documents consistent with this Resolution; and declaring the necessity that this Resolution become immediately effective.
--	--

WHEREAS, the County Executive/Department of Health and Human Services/Division of Senior and Adult Services has recommended an amendment to Contract No. 256 with Lutheran Metropolitan Ministry for adult guardianship services for the period 1/1/2021 – 12/31/2021 to extend the time period to 12/31/2022 and for additional funds in the amount not-to-exceed \$605,285.00; and

WHEREAS, the primary goal of this project is to provide legal guardians to serve as concerned, caring advocates and surrogate decision-makers for indigent persons who are deemed incompetent by the Cuyahoga County Probate Court and who have no appropriate family member or other person available to provide legal guardian services, including concerns of health, education, welfare and fiduciary responsibility; and

WHEREAS, this project is funded by both the Health and Human Services Levy and the Probate Court Indigent Guardianship Fund, and the funding split is to be determined based on the level of funding available in the Indigent Guardianship Fund; and

WHEREAS, it is necessary that this Resolution become immediately effective in order that critical services provided by Cuyahoga County can continue and to provide for the usual, daily operation of a County entity.

**NOW, THEREFORE, BE IT RESOLVED BY THE COUNTY COUNCIL OF CUYAHOGA COUNTY, OHIO:**

**SECTION 1.** That the Cuyahoga County Council hereby authorizes an amendment to Contract No. 256 with Lutheran Metropolitan Ministry for adult guardianship services for the period 1/1/2021 – 12/31/2021 to extend the time period to 12/31/2022 and for additional funds in the amount not-to-exceed \$605,285.00.



First Reading/Referred to Committee:  
Committee(s) Assigned:

Journal \_\_\_\_\_  
\_\_\_\_\_, 20\_\_

Division of Senior and Adult Services – RQ# 45672 – AMENDMENT 1 – Lutheran Metropolitan Ministry – Contract – Adult Guardianship Services

Scope of Work Summary

Division of Senior and Adult Services requesting approval of a contract with Lutheran Metropolitan Ministry for the anticipated cost not to exceed \$1,815,855.00. This is the first amendment to add \$605,285.00. Changing the term to add an additional year to the contract, with new end date to be 12/31/22. No change to the scope of service.

Prior Board Approval Number or Resolution Number:

Original Contract            \$1,210,570.00            R2019-0232

Lutheran Metropolitan Ministry will administer a program to provide guardians for seniors and adults with disabilities throughout Cuyahoga County. The anticipated start-completion dates are 1/1/20-12/31/22. The anticipated start date is Effective Date. The contract ends 12/31/22

The primary goal of the project is to provide legal guardians to serve as concerned, caring advocates and surrogate decision-makers for indigent people who are deemed incompetent by the Cuyahoga County Probate Court.

Procurement

The procurement method for this project was RFP. The total value of the RFP is \$1,210,570.00.

Contractor and Project Information

The address(es) of all vendors and/or contractors is:

Lutheran Metropolitan Ministry  
4515 Superior Avenue  
Cleveland, Ohio 44103

Council District 7

The executive director for the contractor is Andrew Genzler.

The project shall occur countywide.

Project Status and Planning

The project reoccurs annually.

Funding

The project is funded by both the Health and Human Services Levy and the Probate Court Indigent Guardianship Fund, and the funding split is to be determined based on the level of funding available in the Indigent Guardianship Fund.

The schedule of payments is monthly, by invoice.

The project is an amendment to a contract. This amendment changes the value by adding \$605,285.00 and is the first amendment of the contract.

## Department of Purchasing – Required Documents Checklist

Upload as “word” document in Infor

Infor/Lawson RQ#:	
Buyspeed RQ# (if applicable):	45672
Infor/Lawson PO# Code (if applicable):	N/A-CE1900361-01 CONV
CM Contract#	256

<b>AMENDMENT #1</b>	<b>Department</b>	<b>Clerk of the Board</b>
Briefing Memo	PC	Attached

Late Submittal Required:	Yes <input type="checkbox"/>	No <input checked="" type="checkbox"/>
Why is the amendment being submitted late?		
What is being done to prevent this from reoccurring?		

TAC or CTO Required or authorized IT Standard	Yes <input type="checkbox"/>	No <input checked="" type="checkbox"/>
---	------------------------------	--

Contract Amendments Reviewed by Purchasing				
Lutheran Metropolitan Ministry- Adult Guardianship			Department initials	Purchasing
Justification Form			PC	OK
IG#	IG# 12-1788-REG exp 12/31/2021			OK
Annual Non-Competitive Bid Contract Statement – <i>(only needed if not going to BOC or Council for approval)</i>	Date:	1/31/21	PC	Attached – No longer required
Debarment/Suspension Verified	Date:	<del>08/12/2021</del> 9/28/2021	PC	Revised needed – uploaded 10/7/21 OK
Auditor’s Finding	Date:	<del>08/12/2021</del> 9/16/2021	PC	OK
Vendor’s Submission			PC	Signed amendment uploaded 10/7/21 OK
Independent Contractor (I.C.) Requirement	Date:	3/02/21	PC	OK
Cover – <i>Master amendments only</i>			N/A	N/A
Contract Evaluation			PC	Revised needed - OK
TAC/CTO Approval or IT Standards (attach and identify relevant page #s), if required.			N/A	N/A
Checklist Verification			PC	

Other documentation may be required depending upon your specific item

Glossary of Terms at: <https://intranet.cuyahoga.cc/policies-procedures/procurement-information>

Reviewed by Law	
	Department initials
Agreement/Contract and Exhibits	PC

## Department of Purchasing – Required Documents Checklist

Upload as “word” document in Infor

Matrix Law Screen shot	PC
COI	PC
Workers’ Compensation Insurance	PC
Original Executed Contract (containing insurance terms) & all executed amendments	PC

### Accounting Units

Time Period	Accounting Unit	Account Number	Sub Account	Dollar Amount
01/01/22 – 12/31/22	HS260275	56030	UCH09570	<b>\$605,285.00</b>
			<b>TOTAL</b>	<b>\$605,285.00</b>

<b>Contract History CE/AG# (if applicable)</b>	CE1900361
<b>Infor/Lawson PO# Code (if applicable)</b>	N/A- <del>CE1900361-01</del> CONV
<b>Lawson RQ# (if applicable)</b>	45672
<b>CM Contract#</b>	256

	Original Amount	Amendment Amount	Original Time Period/Amended End Date	Approval Date	Approval #
<b>Original Amount</b>	<del>\$1,210,570.00</del> \$1,210,750.00 **Deviation form and revised resolution uploaded 10/19/2021		1/1/2020 – 12/31/2021	<del>11/14/2019</del> 11/12/2019	<b>R2019-0232</b>
<b>Prior Amendment Amounts (list separately)</b>		\$ N/A			
<b>Pending Amendment</b>		\$605,285.00	12/31/22	Pending	Pending
<b>Total Amendments</b>		\$605,2875.00			
<b>Total Contact Amount</b>		\$1,815,855.00			

### Purchasing Use Only:

Prior Resolutions:	R2019-0232
Amend:	256

## **Department of Purchasing – Required Documents Checklist**

Upload as “word” document in Infor

Vendor Name:	Lutheran Metropolitan Ministry
ftp:	1/1/2020 – 12/31/2022; effective 1/1/2022
Amount:	Add'l \$605,285.00 MM
History/CE:	OK
EL:	OK
Procurement Notes:	10/7/2021: Amendment is not signed by the vendor. Debarment Form is missing a date and signature. Contract Evaluation Form references that the contract was awarded in 2017. Expiration Date on Line 1 needs to be updated to 12/31/2020, Line 2 Description should read 2021 Additional Certification not Amendment. The Amendment funding will need to be added as an additional certification once the 2022 Budget has been added to INFOR. R2019-0232 was approved for funding in the amount of \$1,210,750.00 and does not match the contract or the contract cover, was the Resolution ever Amended to correct the amount? TN

Purchasing Buyer approval: TN 10/22/2021

3 | Page

Revised 9/17/2021



## CONTRACT EVALUATION FORM

<b>Contractor</b>	Lutheran Metropolitan Ministry				
<b>Current Contract History: CE/AG# (if applicable) Infor/Lawson PO#:</b>	CM256 CE1900361				
<b>RQ#</b>	45672				
<b>Time Period of Original Contract</b>	01/01/20-12/31/21				
<b>Background Statement</b>	In 2020 Lutheran Metropolitan Ministry (LMM) was awarded the contract to provide shelter services for single adults through an RFP process.				
<b>Service Description</b>	LMM manages a 365-bed adult emergency shelter 24/7 as well as overflow shelter for single adults and families.				
<b>Performance Indicators</b>	Number of people assisted annually; exits to permanent housing.				
<b>Actual Performance versus performance indicators (include statistics):</b>	LMM served approximately 3,000 unduplicated persons in 2020; 13% of those who exited the shelter left to a permanent housing option.				
<b>Rating of Overall Performance of Contractor</b>	<b>Superior</b>	<b>Above Average</b>	<b>Average</b>	<b>Below Average</b>	<b>Poor</b>
<b>Select One (X)</b>		X			
<b>Justification of Rating</b>	LMM provides basic shelter and housing linkages for single adults with an emphasis on a client focused, trauma informed approach.				
<b>Department Contact</b>	Paul Porter				
<b>User Department</b>	Division of Senior and Adult Services				
<b>Date</b>	09/15/2021				

# County Council of Cuyahoga County, Ohio

## Resolution No. R2021-0246

Sponsored by: <b>County Executive Budish/Department of Development</b>	<b>A Resolution;</b> authorizing Contract No. 1904 with Fund for Our Economic Future of Northeast Ohio, as fiscal agent, in the amount not-to-exceed \$1,450,000.00 to support workforce innovation and coordination in healthcare, manufacturing, information technology and hospitality sectors in connection with the Workforce Connect Development Program for the period 1/1/2022 – 12/31/2024; authorizing the County Executive to execute the contract and all other documents consistent with this Resolution; and declaring the necessity that this Resolution become immediately effective.
--	---

WHEREAS, the County Executive/Department of Development has recommended Contract No. 1904 with Fund for Our Economic Future of Northeast Ohio, as fiscal agent, in the amount not-to-exceed \$1,450,000.00 to support workforce innovation and coordination in healthcare, manufacturing, information technology and hospitality sectors in connections with the Workforce Connect Development Program for the period 1/1/2022 – 12/31/2024; and

WHEREAS, the funders collaborative will focus on the healthcare, manufacturing and IT sectors; and

WHEREAS, the primary goal for this project is to target employment of second chance/reentry workers and develop relationship among funders to be catalyst of change to the workforce system; and

WHEREAS, this project is 100% funded by the General Fund; and

WHEREAS, it is necessary that this Resolution become immediately effective in order that critical services provided by Cuyahoga County can continue.

**NOW, THEREFORE, BE IT RESOLVED BY THE COUNTY COUNCIL OF CUYAHOGA COUNTY, OHIO:**

**SECTION 1.** That the Cuyahoga County Council hereby authorizes Contract No. 1904 with Fund for Our Economic Future of Northeast Ohio, as fiscal agent, in the

amount not-to-exceed \$1,450,000.00 to support workforce innovation and coordination in healthcare, manufacturing, information technology and hospitality sectors in connections with the Workforce Connect Development Program for the period 1/1/2022 – 12/31/2024.

**SECTION 2.** That the County Executive is authorized to execute the contact all documents consistent with said award and this Resolution.

**SECTION 3.** It is necessary that this Resolution become immediately effective for the usual daily operation of the County; the preservation of public peace, health or safety in the County; and any additional reasons set forth in the preamble. Provided that this Resolution receives the affirmative vote of at least eight members of Council, it shall take effect and be in force immediately upon the earliest occurrence of any of the following: (1) its approval by the County Executive through signature, (2) the expiration of the time during which it may be disapproved by the County Executive under Section 3.10(6) of the Cuyahoga County Charter, or (3) its passage by at least eight members of Council after disapproval pursuant to Section 3.10(7) of the Cuyahoga County Charter. Otherwise, it shall take effect and be in force from and after the earliest period allowed by law.

**SECTION 4.** It is found and determined that all formal actions of this Council relating to the adoption of this Resolution were adopted in an open meeting of the Council, and that all deliberations of this Council and of any of its committees that resulted in such formal action were in meetings open to the public, in compliance with all legal requirements, including Section 121.22 of the Ohio Revised Code.

On a motion by \_\_\_\_\_, seconded by \_\_\_\_\_, the foregoing Resolution was duly adopted.

Yeas:

Nays:

\_\_\_\_\_  
County Council President

\_\_\_\_\_  
Date

\_\_\_\_\_  
County Executive

\_\_\_\_\_  
Date

\_\_\_\_\_  
Clerk of Council

\_\_\_\_\_  
Date

First Reading/Referred to Committee: October 26, 2021  
Committee(s) Assigned: Committee of the Whole

Journal \_\_\_\_\_  
\_\_\_\_\_, 20\_\_

Title: Department of Development  
2022-2024  
Fund for the Economic Future of NEO  
RFP Exemption  
Fund for the Economic Future of NEO 2022-2024

#### Scope of Work Summary

The Department of Development is requesting approval of a contract with Fund for the Economic Future of NEO for the anticipated cost \$1,450,000.00.

This project was previously approved in 2019 via Resolution 2018-0138.

The Fund for the Economic Future of NEO is being contracted as the Fiscal Sponsor of the Cuyahoga Workforce Funders Group (CCWFG) to continue to drive system changes in workforce development. The emphasis is on strengthening the workforce pipeline, assisting workers with employment barriers to connect to employers and build alignment among public, private and philanthropic funders. The anticipated start-completion dates are 1/1/2022 and 12/31/2024.

The primary goals of the project are (list 2 to 3 goals).

- Target employment of “second chance”/reentry workers
- Develop relationships among funders to be catalyst of change to the workforce system
- Workforce development in Manufacturing, Healthcare, IT and Hospitality sectors

#### Procurement

An RFP Exemption is being requested for this contract. Since 2019 the Fund for Economic Future of NEO has filled the role of fiscal sponsor. They are positioned to develop relationships among community partners and employers.

The total value of the is \$1,450,000.00.

#### Contractor and Project Information

Fund for Our Economic Future  
4415 Euclid Avenue, Suite 203  
Cleveland, OH 44103  
Council District – 7

The project will have an impact in all Council Districts.

Bethia Burke - President

#### Project Status and Planning

The project reoccurs every few years. The project’s term will commence on January 1, 2022 and conclude December 31, 2024.

#### Funding

The project is funded 100% by the General Fund.

Payment is made annual through submitted invoices.

## Department of Purchasing – Required Documents Checklist

Upload as “word” document in Infor

Infor/Lawson RQ#:	N/A
Infor/Lawson PO # Code (if applicable):	N/A
CM Contract#	1904

	<b>Department initials</b>	<b>Clerk of the Board</b>
Briefing Memo	CF	<input type="checkbox"/>

Late Submittal Required:	Yes <input type="checkbox"/>	No <input checked="" type="checkbox"/>
Why is the contract being submitted late?		
What is being done to prevent this from reoccurring?		

TAC or CTO Required or authorized IT Standard	Yes <input type="checkbox"/>	No <input checked="" type="checkbox"/>
---	------------------------------	--

<b>OTHER THAN FULL AND OPEN COMPETITION RFP Exemptions (Contract) Reviewed by Purchasing</b>
--

				Department initials	Purchasing
Justification Form				CF	OK Jgas 10-13/2021
IG#	19-0013-REG	31DEC2023		CF	OK Jgas 10-13/2021
Annual Non-Competitive Bid Contract Statement - <i>(only needed if not going to BOC or Council for approval)</i>	Date:			N/A	N/A Per DOP director, Catherine Tkachyk, email dated 8/31/2021: 1)If the item goes to Board of Control or County Council for a vote, the form is not required. This includes the items listed on the consent agenda as already purchased as they are voted on.
Debarment/Suspension Verified	Date:	10/1/2021		CF	OK Jgas 10-13/2021 dated within 60 days.
Auditor’s Finding	Date:	10/1/2021		CF	OK Jgas 10-13/2021 dated within 60 days.
Vendor’s Submission				CF	OK Jgas 10-13/2021
Independent Contractor (I.C.) Requirement	Date:	6/28/2021		CF	OK Jgas 10-13/2021

## Department of Purchasing – Required Documents Checklist

Upload as “word” document in Infor

Cover - <i>Master contracts only</i> FUND FOR OUR ECONOMIC FUTURE OF NEO 27-0606927 4415 Euclid Avenue, Suit 203 Cleveland, OH 44103 Carolyn Cleveland 216-456-9811	N/A	
Contract Evaluation – <i>if required</i>	CF	OK Jgas 10-13/2021
TAC/CTO Approval or IT Standards (attach and identify relevant page #s), if required.	N/A	N/A
Checklist Verification	CF	OK Jgas 10-13/2021

Other documentation may be required depending upon your specific item

Glossary of Terms at: <https://intranet.cuyahoga.cc/policies-procedures/procurement-information>

### OTHER THAN FULL AND OPEN COMPETITION RFP Exemptions (Contract) Reviewed by Law

	Department initials
Agreement/Contract and Exhibits	CF
Matrix Law Screen shot	CF
COI	CF
Workers' Compensation Insurance	CF

### Accounting Units

Time Period	Accounting Unit	Account Number	Sub Account	Dollar Amount
1/1/2022 – 12/31/2022	DV220110	55130	DEVECD001	\$725,000.00
1/1/2023 – 12/31/2023	DV220110	55130	DEVECD001	\$362,500.00
1/1/2024 – 12/31/2024	DV220110	55130	DEVECD001	\$362,500.00
			<b>TOTAL</b>	\$1,450,000.00

<b>Contract History CE/AG# (if applicable)</b>	CM-1621 / CE1900142-01
<b>Infor/Lawson PO# and PO Code (if applicable)</b>	SOLC
<b>Lawson RQ# (if applicable)</b>	44628
<b>CM Contract#</b>	1621

## Department of Purchasing – Required Documents Checklist

Upload as “word” document in Infor

	Original Amount	Amendment Amount	Original Time Period/Amended End Date	Approval Date	Approval #
<b>Original Amount</b>	\$1,000,000.00		1/1/2019-12/31/2021	09/13/2018	R2018-0138
<b>Prior Amendment Amounts (list separately)</b>		\$100,000.00	1/1/2019-12/31/2021	06/24/2019	BC2019-478
		\$			
		\$			
<b>Pending Amendment</b>		\$			
<b>Total Amendments</b>		\$			
<b>Total Contact Amount</b>	<b>\$1,100,000.00</b>	\$			

### Purchasing Use Only:

Prior Resolutions:	R2018-0138 dated 09/13/2018; BC2019-478 dated 06/24/2019.
CM#:	1904
Vendor Name:	Fund for Our Economic Future of Northeast Ohio
ftp:	1/1/2022 – 12/31/2024
Amount:	NTE 1,450,000.00
History/CE:	CM-1621 / CE1099142-01
EL:	OK
Procurement Notes:	Contract with Fund for Our Economic Future of Northeast Ohio to serve as fiscal sponsor for "Workforce Connect" development program ftp of 1/1/2022 – 12/31/2024 in the amount NTE \$1,450,000.00. An RFP exemption for this procurement was requested.
Purchasing Buyer approval:	Jgas 10/13/2021



## CONTRACT EVALUATION FORM

<b>Contractor</b>	Fund for Our Economic Future of NEO				
<b>Current Contract History: CE/AG# (if applicable) Infor/Lawson PO#:</b>	CM 1621				
<b>RQ#</b>	DV-19-44628				
<b>Time Period of Original Contract</b>	January 1, 2019 to December 31, 2021				
<b>Background Statement</b>	The Department of Development contracted with the Fund for our Economic Future to serve as fiscal sponsor and to monitor the creation of up to 3 sector partnership intermediaries for workforce development.				
<b>Service Description</b>	Provides funding to support the manufacturing, health care, and information technology sector partnerships.				
<b>Performance Indicators</b>	Each of the three sector partnerships was to select a “backbone” organization, form employer groups, and develop specific programs to improve talent attraction in its respective sector.				
<b>Actual Performance versus performance indicators (include statistics):</b>	Despite the unexpected COVID-19 pandemic, each sector partnership did form and employer group, select a backbone organization, and develop and start to implement specific programs.				
<b>Rating of Overall Performance of Contractor</b>	<b>Superior</b>	<b>Above Average</b>	<b>Average</b>	<b>Below Average</b>	<b>Poor</b>
<b>Select One (X)</b>		X			
<b>Justification of Rating</b>	The three sector partnerships fulfilled their initial work plans to organize employer groups, select backbone organizations, and develop and start to implement programs, despite COVID-19.				
<b>Department Contact</b>	Paul Herdeg, Director (216) 443-7257				
<b>User Department</b>	Development				
<b>Date</b>	October 4, 2021				

**EXHIBIT I – Statement of Work**

**Cuyahoga County Workforce Funders Group  
2022-24 Strategic Direction**

**OVERVIEW**

Cuyahoga County Workforce Funders Group’s (Funders Group) second strategic phase (2022-24) will focus on scaling impacts of Workforce Connect for workers and businesses and strengthening the collective and individual ability of public and civic sector funders to drive change to critical systems-level issues impacting Cuyahoga County’s workforce system. Much has changed in the region (and the world) since the launch of the Funders Group in 2015. Evolving civic, political, and business leadership; the stark impact of the coronavirus pandemic; and social uprisings fueled by racial injustice have pushed the Funders Group to revisit its strategies. In Phase II, the Funders Group remains highly aligned to Cuyahoga County’s Five-Year Economic Development Plan, including continued emphasis on strengthening workforce pipelines, assisting workers with employment barriers to connect to careers that pay family-sustaining wages and building alignment among public, private and philanthropic funders. The requested commitment from the County is \$1,450,000 over three years (2022-24), to accelerate impacts of the Manufacturing, Healthcare and IT sector partnerships (\$1,100,000) and support workforce innovation and coordination in the Hospitality sector (\$350,000).

**FUNDERS GROUP’S NORTH STAR**

We continue to strive for a workforce system that centers diversity, equity and inclusion. We are committed to investing deeply in proven strategies and scaling them for greater impact. We aspire to elevate key learnings and successes from our collective effort to push for policy and funding reforms that create greater access to opportunity for diverse talent, robust business growth, and a competitive region.



The Funders Group leverages the individual and collective influence, investments, and insights of its members to drive system change and equitable outcomes in workforce development.<sup>1</sup>



We envision a highly skilled, valued, and talented workforce in Cuyahoga County that fuels business growth and competitiveness, vibrant communities and thriving families.



Collaboration  
Learning  
Equity  
Inclusion  
Excellence  
Transparency  
Accountability

<sup>1</sup> Workforce development is the coordination of public and private sector policies and programs that strengthen family-sustaining career paths, enhance training/supports that help adults and youth connect to, advance and thrive in careers (with particular focus on two years of training or less) and actively support employers to source and retain workers they need to compete and grow, to meet needs for today and in the future. Workforce development not only targets an individual’s or employer’s skills needs, it also addresses structural inequities and barriers that block access and advancement in family-sustaining careers, such as from employer hiring practices, racial bias or transportation access.

## FUNDERS GROUP DESIRED COLLECTIVE IMPACT

- **Closing the talent (demand-supply) gap** in Northeast Ohio’s in-demand industries to ensure businesses have the talent they need to grow and prosper.
- **Family sustaining jobs and career opportunities** for workers, especially for those who face barriers to sustained, quality employment.
- **Closing the racial income and employment gap** faced by Black and Latinx workers in Cuyahoga County by addressing employer practices and policies that impact workforce diversity, racial equity and inclusion.
- **Greater coordination** among workforce funders demonstrated by shared goals and strategic, aligned and coordinated investments in Cuyahoga County’s workforce system to drive long-term structural improvements.

## CORE STRATEGIES

- **Sustain and scale impact of sector partnerships (Workforce Connect)** to address critical talent gaps in key industries, including continuing to collectively invest in intermediary capacity, and supporting innovative efforts that can improve and/or accelerate impacts for workers and businesses, especially those that can bolster multiple sector partnerships through a single investment.
- **Foster shared, active learning among Funders Group members** to unlock the collective and individual actions members can take to drive workforce systems change, including elevating and championing local and national workforce innovations and practices that are ripe for local collective and/or individual action.
- **Leverage the many roles of the Funders Group (advocate, thought leader, convenor)** to transform Cuyahoga County’s workforce development system in alignment with our mission, vision and values.

## KEY ROLES

	<b>Funders Group</b>	<b>Fund for Our Economic Future (fiscal sponsor)</b>
Support & Track Progress	Provide mentorship, technical assistance, resources and support to sector partnerships to drive desired impacts	
	Monitor and assess progress	
Payments	Set terms and conditions of payment, including accountability for progress	Issue payments
	Approve payment release; provided that the Cuyahoga County Department of Development reserves the right in its sole discretion, to prohibit the use of any County funds as a part of any payment	
Governance	Approve and modify budgets	Records keeping (e.g., executed conflict of interest)
	Approve communication plans.	Aggregated pooled funds

	Ensure alignment with workforce funders group governance processes (e.g. membership, leadership)	
Competitive Procurement Processes	Draft procurement documents (e.g., request for proposals (RFP)) Determine selection process Select supporting contractors or relevant grantees	Receive Responses Execute agreements with supporting contractor(s) and selected sector partnership intermediary(ies)
Other	Communicate with public as appropriate	Report on financials to funders

**EXHIBIT II – FUNDERS GROUP BUDGET**

Funders Group’s pooled funds will be managed flexibly and nimbly to advance this three-year strategy. The following represents a starting point budget, which will be reviewed and revised regularly as appropriate.

Minimum Budget represents the projected budget in which the County’s contribution to Funders Group Core Strategies (\$1,100,000) is equivalent to 40% of the Funders Group Core Strategies Subtotal, and contributions of other Funders Group members and additional funders aligning resources (at minimum \$1,650,000) are equivalent to 60% of the Core Strategies Subtotal. This budget includes only support for sustaining and scaling impacts of sector partnerships and facilitation.

Preferred Budget represents the projected budget to fully implement the Funders Group Strategic Direction for 2022-24.

Workforce Funders Group Projected Expenditures 2022-2024; <i>Minimum Budget &amp; Preferred Budget</i>	<i>Minimum Budget</i>				<i>Preferred Budget</i>
	<b>Year 1 2022</b>	<b>Year 2 2023</b>	<b>Year 2 2024</b>	<b>Total Minimum</b>	<b>Total Preferred</b>
<b><i>Funders Group Core Strategies</i></b>					
Sustain and scale impacts of sector partnerships (Manufacturing, Healthcare, IT)	\$700,000	\$800,000	\$900,000	<b>\$2,400,000</b>	\$2,400,000
Best practices research & resources					\$60,000 – \$180,000
Policy and narrative change support					\$25,000 – 50,000
(Support) Facilitation	\$117,000	\$117,000	\$116,000	<b>\$350,000</b>	\$450,000
(Support) Communications					\$90,000
<b>Funders Group Core Strategies Subtotal</b>	<b>\$817,000</b>	<b>\$917,000</b>	<b>\$1,016,000</b>	<b>\$2,750,000</b>	\$3,025,000– \$3,170,000
<b><i>Hospitality Sector</i></b>					
Hospitality sector workforce innovation & coordination	\$175,000	\$125,000	\$50,000	<b>\$350,000</b>	\$350,000
<b>Funders Group Total Projected Expenditures</b>	<b>\$992,000</b>	<b>\$1,042,000</b>	<b>\$1,066,000</b>	<b>\$3,100,000</b>	\$3,375,000– \$3,520,000

# County Council of Cuyahoga County, Ohio

## Resolution No. R2021-0218

Sponsored by: <b>County Executive Budish/Fiscal Officer/Office of Budget and Management</b>	<b>A Resolution</b> amending the 2020/2021 Biennial Operating Budget for 2021 by providing for additional fiscal appropriations from the General Fund and other funding sources, for appropriation transfers between budget accounts and for cash transfers between budgetary funds, to meet the budgetary needs of various County departments, offices and agencies; and declaring the necessity that this Resolution become immediately effective.
---	--

WHEREAS, on December 10, 2019, the Cuyahoga County Council adopted the Biennial Operating Budget and Capital Improvements Program for 2020/2021 (Resolution No. R2019-0224) establishing the 2020/2021 biennial budget for all County departments, offices and agencies; and

WHEREAS, it is necessary to adjust the Biennial Operating Budget for 2021 to reflect budgetary funding increases, funding reductions, to transfer budget appropriations and to transfer cash between budgetary funds, to accommodate the operational needs of certain County departments, offices and agencies; and

WHEREAS, it is further necessary that this Resolution become immediately effective in order that critical services provided by Cuyahoga County can continue and to provide for the usual, daily operation of County departments, offices, and agencies.

**NOW, THEREFORE, BE IT RESOLVED BY THE COUNTY COUNCIL OF CUYAHOGA COUNTY, OHIO:**

**SECTION 1.** That the 2020/2021 Biennial Operating Budget for 2021 be amended to provide for the following additional appropriation increases and decreases:

**Fund Nos./Budget Accounts**

**Journal Nos.**

A. General Fund		
FS100105 – Office of Budget & Management		
Other Expenses	\$	5,250,000

The Office of Budget and Management is requesting an appropriation increase in the amount of \$5,250,000. This appropriation request is for a contribution to the Ball Park Improvement Fund established under the indenture authorized by Resolution Number R2021-0219. This will reduce the County’s future obligations. Funding source is General Fund.

**SECTION 2.** That the 2020/2021 Biennial Operating Budget for 2021 be amended to provide for the following appropriation transfers:

**SECTION 3.** That the 2020/2021 Biennial Operating Budget for 2021 be amended to provide for the following cash transfers between County funds:

**SECTION 4.** It is necessary that this Resolution become immediately effective for the usual daily operation of the County; the preservation of public peace, health, or safety in the County; and any additional reasons set forth in the preamble. Provided that this Resolution receives the affirmative vote of at least eight members of Council, it shall take effect and be in force immediately upon the earliest occurrence of any of the following: (1) its approval by the County Executive through signature, (2) the expiration of the time during which it may be disapproved by the County Executive under Section 3.10(6) of the Cuyahoga County Charter, or (3) its passage by at least eight members of Council after disapproval pursuant to Section 3.10(7) of the Cuyahoga County Charter. Otherwise, it shall take effect and be in force from and after the earliest period allowed by law.

**SECTION 5.** It is found and determined that all formal actions of this Council relating to the adoption of this Resolution were adopted in an open meeting of the Council, and that all deliberations of this Council and of any of its committees that resulted in such formal action were in meetings open to the public, in compliance with all legal requirements, including Section 121.22 of the Ohio Revised Code.

On a motion by \_\_\_\_\_, seconded by \_\_\_\_\_, the foregoing Resolution was duly adopted.

Yeas:

Nays:







To: Andria Richardson, Clerk of County Council

From: Walter Parfejewiec, Office of Budget and Management

Date: September 20, 2021

Re: Fiscal Agenda – 9/28/2021 - Proposed

cc: Michael Chambers, Fiscal Office; Mary Louise Madigan, Communications

The Office of Budget & Management requests that the members of County Council consider the attached fiscal resolution for approval on first reading at the meeting on **September 28, 2021**. The requested fiscal items, including additional appropriations, appropriation transfers, and cash transfers, are necessary to reconcile the originally adopted 2020 Budget. Items of note on this agenda include:

- Request to provide appropriation increase.

**Additional Appropriation Summary** – Additional appropriation is requested to cover expenditures that exceed the original estimate and must be supported by a revenue source. A reduction in appropriation is requested in conjunction with the close-out of a program, grant, or decertification of an encumbrance.

Department	Amount Requested	Item	Funding Source	Purpose
OBM	\$5,250,000.00	A	General Fund	Appropriation Increase

# County Council of Cuyahoga County, Ohio

## Resolution No. R2021-0219

<p>Sponsored by: <b>County Executive Budish/Fiscal Officer/Office of Budget and Management</b></p>	<p><b>A Resolution</b> authorizing the issuance and sale of one or more series of County sales tax revenue bonds, in an aggregate principal amount not to exceed \$202,500,000, for the purpose of paying or reimbursing the costs of reconstructing, refurbishing, renovating, upgrading, improving and equipping Progressive Field, together with appurtenances and work incidental thereto, and for the purpose of paying any capitalized interest on the bonds, making any required reserve deposits and paying the costs of issuance in connection therewith; authorizing the preparation and use of one or more preliminary official statements and the preparation, execution and use of one or more official statements; approving and authorizing the execution of one or more trust indentures or supplemental trust indentures and one or more continuing disclosure agreements; authorizing other contracts and other actions related to and necessary for the issuance of the bonds; and declaring the necessity that this Resolution become immediately effective.</p>
--	--

WHEREAS, the County, in cooperation with Gateway Economic Development Corporation of Greater Cleveland (“Gateway”), the City of Cleveland, the Cleveland Indians Baseball Company, LLC (or any successor organization, the “Team”) and other civic partners, participated in the financing and refinancing the costs of the construction and improvement of the multi-purpose ball park now known as Progressive Field (the “Ball Park”); and

WHEREAS, the Team, as lessee and operator of the Ball Park, in cooperation with Gateway and the County, has proposed to undertake the reconstructing, refurbishing, renovating, upgrading, improving and equipping of the Ball Park (the “Project”), together with appurtenances and work incidental thereto; and

WHEREAS, the County is authorized pursuant to Section 307.023 of the Ohio Revised Code to acquire, construct, improve, maintain, operate, lease, or otherwise contract for the acquisition or use of sports facilities intended to house major league professional athletic teams, such as the Ball Park; and

WHEREAS, the Project improvements to the Ball Park constitute “permanent improvements” pursuant to Section 133.01(CC) of the Ohio Revised Code; and

WHEREAS, the County is authorized pursuant to Section 133.081 of the Ohio Revised Code to issue Sales Tax Revenue Bonds of the County for the purpose of paying all or any portion of the costs of any permanent improvement;

WHEREAS, pursuant to a resolution adopted July 6, 1987 (the “1987 County Sales Tax Resolution”), the Board of County Commissioners of the County (the “Board”), as the predecessor legislative authority to this Council, authorized the continuing levy and collection of sales and use taxes, authorized under Sections 5739.021 and 5741.021 of the Ohio Revised Code, at the rate of one percent (1%) (the “Original County Sales Tax”), and pursuant to a resolution adopted July 26, 2007 (the “2007 County Sales Tax Resolution” and, together with the 1987 County Sales Tax Resolution, the “County Sales Tax Resolutions”), the Board authorized an increase in the sales and use taxes by an additional one-quarter percent (1/4%) approved through 2027 (the “Additional County Sales Tax,” and together with the Original County Sales Tax, the “County Sales Tax”), each for the purpose of providing additional general revenues for the County; and

WHEREAS, the County, City, and Gateway are parties to the First Amended and Restated Agreement Relating to Ownership, Financing, Construction and Operation of a Sports Facility and Related Economic and Redevelopment Project by and between Cuyahoga County, the City and Gateway dated September 15, 1992 (the “Three-Party Agreement”); and

WHEREAS, the County acknowledges its role under the Three-Party Agreement and agrees, from time-to-time, and subject to appropriation, to deposit funds in the capital reserve fund to be created under the Supplemental Indenture in response to a request from Gateway regarding capital repairs;

WHEREAS, the Fiscal Officer has certified that the estimated life of the Project is at least five (5) years, and that the estimated maximum maturity of the bonds described in Section 2 is at least fifteen (15) years; and

WHEREAS, the Fiscal Officer has further certified to this Council that the maximum aggregate amount of Sales Tax Revenue Bonds, including the Series 2021 Ball Park Bonds, that will be outstanding at any time will not exceed an amount which requires or is estimated by him, as Fiscal Officer, to require payments from sales tax receipts of debt charges on the Sales Tax Revenue Bonds, including the Series 2021 Ball Park Bonds, in any calendar year in an amount exceeding the County Sales Tax as estimated by the Fiscal Officer based on general County Sales Tax Receipts averaged for the years 2019 and 2020 as required under the Sales Tax Revenue Bond Indenture; and

WHEREAS, this Council has determined that it is necessary and in the best interest of the County for the County to issue one or more series of Sales Tax Revenue Bonds for the purpose of paying or reimbursing the costs of the Project, together with appurtenances and work incidental thereto, and for the purpose of paying any capitalized interest on such bonds, to fund any required deposit to a bond reserve fund, and to pay certain costs of issuance in connection with the Series 2021 Ball Park Bonds; and

WHEREAS, the County has determined that such Sales Tax Revenue Bonds shall be issued in one or more series, in an aggregate principal amount not to exceed \$202,500,000, for the purposes herein stated and that the County shall secure such Sales Tax Revenue Bonds by one or more trust indentures or supplemental trust indentures, as provided herein; and

WHEREAS, it is necessary that this Resolution become immediately effective in order that the usual daily operation of the County be continued and the public peace, health or safety of the County be preserved and for the further reason that funds be made available in a timely manner for the construction of the Project.

**NOW, THEREFORE, BE IT RESOLVED BY THE COUNTY COUNCIL OF CUYAHOGA COUNTY, OHIO:**

1. Definitions and Interpretation. As used herein, the following terms shall be defined as follows:

“Bond Counsel” means Tucker Ellis LLP.

“Bond Service Charges” means Bond Service Charges on Series 2021 Ball Park Bonds as defined in the applicable Supplemental Indenture.

“Book entry form” or “book entry system” means a form or system' under which (a) the ownership of book entry interests in Series 2021 Ball Park Bonds and the principal of and interest on the Series 2021 Ball Park Bonds may be transferred only through a book entry, and (b) physical Bond certificates in fully registered form are issued by the County only to a Depository or its nominee as registered owner, with the Series 2021 Ball Park Bonds deposited with and retained in the custody of the Depository or its agent. The book entry maintained by others than the County is the record that identifies the owners of book entry interests in those Series 2021 Ball Park Bonds and that principal and interest.

“Certificate of Award” means the one or more certificates authorized to be signed by the Fiscal Officer pursuant to Section 6, specifying and determining those terms or other matters pertaining to the Series 2021 Ball Park Bonds and their issuance, sale and delivery as this Resolution requires or authorizes to be set forth or determined therein.

“Closing Date” means the date or dates of original delivery of, and payment of the purchase price for, the Series 2021 Ball Park Bonds.

“Code” means the Internal Revenue Code of 1986, the Regulations (whether temporary or final) under that Code or the statutory predecessor of that Code, and any amendments of, or successor provisions to, the foregoing and any official rulings, announcements, notices, procedures and judicial determinations regarding any of the foregoing, all as and to the extent applicable. Unless otherwise indicated, reference to a Section of the Code includes any applicable successor section or provision and such applicable Regulations, rulings, announcements, notices, procedures and determinations pertinent to that Section.

“Continuing Disclosure Certificate” means the one or more certificates authorized by Section 6(c) hereof which, together with the agreements of the County set forth in that Section, shall constitute the continuing disclosure agreement made by the County for the benefit of holders and beneficial owners of the Series 2021 Ball Park Bonds in accordance with the Rule.

“County Executive” means the County Executive of the County; provided, for purposes of the signing of documents, certificates and other instruments other than the Series 2021 Ball Park Bonds and the Official Statement, County Executive includes the County Executive's Chief of Staff as the County Executive's designee pursuant to Executive Order No. E02015-0001 and any other person duly designated by the County Executive.

“County Sales Tax Bond Fund” means the County Sales Tax Bond Fund created by the Sales Tax Revenue Bond Indenture.

“County Sales Tax Receipts” means the monies received by the County from the County Sales Tax.

“County Sales Tax Revenue Fund” means the County Sales Tax Revenue Fund created by the Sales Tax Revenue Bond Indenture.

“Cuyahoga County Excise Tax Facilities Improvement Fund” means the Cuyahoga County Excise Tax Facilities Improvement Fund established pursuant to the Trust Indenture dated as of December 1, 2015 between the County and U.S. Bank National Association, as trustee thereunder.

“Depository” means The Depository Trust Company (a limited purpose trust company), New York, New York until a successor Depository shall have become such pursuant to the applicable provisions of the Sales Tax Revenue Bond Indenture and, thereafter, Depository shall mean the successor Depository. Any Depository shall be a securities depository that is a clearing agency under federal law operating and maintaining, with its participants or otherwise, a Book Entry System to record ownership of book entry interests in the Series 2021 Ball Park Bonds or Bond Service Charges thereon, and to effect transfers of book entry interests in the Series 2021 Ball Park Bonds.

“Director of Law” means the Director of Law of the County, including an interim or acting Director of Law.

“Facilities Improvement Account” means the Facilities Improvement Account established pursuant to the Excise Tax Depository Agreement, dated as of September 12, 2019 by and between the County and U.S. Bank National Association, as excise tax depository thereunder.

“Fiscal Officer” means the Fiscal Officer of the County, including an interim or acting Fiscal Officer.

“Interest Payment Dates” means, unless otherwise determined by the Fiscal Officer and specified in the Certificate of Award, January 1 and July 1 of each year during which the Series 2021 Ball Park Bonds are outstanding, commencing July 1, 2022.

“Mandatory Sinking Fund Redemption Requirements” means, as to the Series 2021 Ball Park Bonds, the deposits required to be made in respect of the mandatory redemption requirements indicated in the Sales Tax Revenue Bond Indenture.

“Original Purchaser” means such purchaser or purchasers identified as such by the County Fiscal Officer in the Certificate of Award.

“Participant” means any participant contracting with a Depository under a book entry system and includes security brokers and dealers, banks and trust companies, and clearing corporations.

“Pledged Sales Tax Revenue Bond Funds” means the County Sales Tax Bond Fund and any other funds established under the Sales Tax Revenue Bond Indenture and pledged as security for the Series 2021 Ball Park Bonds.

“Pledged Sales Tax Revenues” means, collectively, (a) the County Sales Tax Receipts and (b) all monies in the Pledged Sales Tax Revenue Bond Funds and all income and profit from the investment of those monies.

“Principal Payment Dates” means, unless otherwise determined by the Fiscal Officer and specified in the Certificate of Award, January 1 in each of the years from and including 2022 to and including 2037.

“Project Revenues” means any money and investments received in connection with the Project and pledged to one or more series of Series 2021 Ball Park Bonds, pursuant to the Sales Tax Revenue Bond Indenture.

“Purchase Agreement” means, with respect to the Series 2021 Ball Park Bonds, one or more Bond Purchase Agreements between the County and the Original Purchaser.

“Rule” means Rule 15c2-12(b)(5) promulgated by the Securities and Exchange Commission pursuant to the Securities Exchange Act of 1934, as it may be amended from time to time.

“Sales Tax Revenue Bonds” means the Series 2021 Ball Park Bonds and other bonds that are currently outstanding or that the County may issue in the future that are secured by the Sales Tax Revenue Bond Indenture.

“Sales Tax Revenue Bond Indenture” means the Trust Indenture dated as of December 1, 2014 between the County and the Sales Tax Revenue Bond Trustee, as amended and supplemented, including by each applicable Sales Tax Revenue Bond Supplemental Indenture.

“Sales Tax Revenue Bond Trustee” means the financial institution designated by the Fiscal Officer in the Certificate of Award, in accordance with Section 9 of this Resolution.

“Sales Tax Revenue Bond Supplemental Indenture” means each Supplemental Trust Indenture executed with respect to a series of the Series 2021 Ball Park Bonds, to be dated the first day of the month in which the Series 2021 Sales Tax Ball Park Bonds are issued, between the County and the Sales Tax Revenue Bond Trustee, and any amendment or supplement thereto.

“Series 2021 Ball Park Bonds” means the County’s Sales Tax Revenue Bonds, Series 2021 (Ball Park Improvement Project) authorized hereunder.

“Sports Facility Improvement Fund” means the Sports Facility Improvement Fund established pursuant to Supplemental Trust Indenture No. 5, dated as of October 1, 2017 by and between the County and The Huntington National Bank, as trustee thereunder.

“Sports Facility Reserve Fund” means the Sports Facility Reserve Fund established pursuant to County Ordinance No. O2020-0017.

“State” means the State of Ohio.

“Taxable Bonds” means any Series 2021 Ball Park Bonds that are not Tax-Exempt Bonds.

“Tax-Exempt Bonds” means any Series 2021 Ball Park Bonds that are issued and sold as obligations to which Section 103 of the Code applies, the interest on which is excluded from gross income for federal income tax purposes and is not an item of tax preference under Section 57 of the Code.

“Tax Status” means the status of Bonds as Tax-Exempt Bonds or Taxable Bonds.

“Term Bonds” means those Series 2021 Ball Park Bonds designated as such in the Certificate of Award, maturing on the date or dates set forth therein, bearing interest payable on each Interest Payment Date and subject to mandatory sinking fund redemption.

Any reference to this Council, the County or to its members or officers, or to other public officers, boards, commissions, departments, institutions, agencies, bodies or entities, shall include those which succeed to their functions,

duties or responsibilities by operation of law and also those who at the time may legally act in their place.

The captions and headings in this Resolution are solely for convenience of reference and in no way define, limit or describe the scope or intent of any Sections, subsections, paragraphs, subparagraphs or clauses hereof. Reference to a Section means a section of this Resolution unless otherwise indicated.

## 2. Authorization and Determinations.

(a) It is necessary to issue Sales Tax Revenue Bonds of the County in an aggregate principal amount not to exceed \$202,500,000 (the "Series 2021 Ball Park Bonds"), which, together with other sources as described in Section 17, will be used for the purpose of paying or reimbursing the costs of the Project, funding any deposit to a Bond Reserve Fund, paying any capitalized interest on the Series 2021 Ball Park Bonds, and paying the costs of issuance in connection therewith.

(b) This Council finds and determines that the Project constitutes permanent improvements pursuant to Section 133.01(CC) of the Ohio Revised Code.

3. Bond Terms. The Series 2021 Ball Park Bonds shall be issued pursuant to the terms of the Sales Tax Revenue Bond Indenture. The Series 2021 Ball Park Bonds may be issued in one or more series, and shall be numbered in such manner as to distinguish each Series 2021 Ball Park Bond from any other Series 2021 Ball Park Bond of the same series. The Series 2021 Ball Park Bonds shall be issued in denominations of \$5,000 or multiples of \$5,000 in excess thereof, but in no case as to a particular maturity date exceeding the principal amount maturing on that date. The Series 2021 Ball Park Bonds shall be dated as determined by the Fiscal Officer, with the true interest cost on the Series 2021 Ball Park Bonds not to exceed five and one-half percent (5.50%) per year (computed on the basis of a 360-day year consisting of twelve 30-day months), provided that if any series of Series 2021 Ball Park Bonds are to be Taxable Bonds, the true interest cost on those Series 2021 Ball Park Bonds shall not exceed seven percent (7.00%) per year, payable on such semiannual dates or annual dates as determined by the Fiscal Officer in the Certificate of Award until the principal amount is paid, and shall mature on such semiannual dates or annual dates as determined by the Fiscal Officer in the Certificate of Award, provided that the final maturity of any Series 2021 Ball Park Bonds shall not be later than January 1, 2037, in accordance with Section 133.21 of the Ohio Revised Code, all as set forth in the Certificate of Award and the Sales Tax Revenue Bond Indenture.

4. Redemption Provisions. The Series 2021 Ball Park Bonds shall mature serially on such dates and in such principal amounts as are fixed by the Fiscal Officer in the Certificate of Award and the applicable Supplemental Indenture, provided that the Series 2021 Ball Park Bonds stated to mature in any year may be issued as Term Bonds payable pursuant to Mandatory Sinking Fund Redemption Requirements as hereinafter defined and further described below and as provided for in the applicable Supplemental Indenture. The Fiscal Officer shall determine in the Certificate of Award whether any of the Series 2021 Ball Park



Bonds shall be issued as Term Bonds and any dates (the “Mandatory Redemption Dates”) on which the principal amount stated above shall be payable pursuant to Mandatory Sinking Fund Redemption Requirements rather than at stated maturity (the “Mandatory Sinking Fund Redemption Requirements”).

The Series 2021 Ball Park Bonds shall be subject to mandatory and optional redemption as provided in the applicable Supplemental Indenture.

5. Execution of Bonds. The Series 2021 Ball Park Bonds shall be designated “Cuyahoga County Sales Tax Revenue Bonds, Series 2021 (Ball Park Improvement Project)”, or such other name as may be designated in the Certificate of Award, including any additional designation that the Fiscal Officer determines is appropriate to identify the Tax Status of Any Series of Series 2021 Ball Park Bonds. The Series 2021 Ball Park Bonds shall contain a summary statement of the purposes for which they are issued; shall state that they are issued pursuant to this Resolution; shall be executed by the County Executive and the Fiscal Officer, in the name and on behalf of the County and in their official capacities, provided that either or both of those signatures may be a facsimile; shall be issued only in fully registered form; and shall be registered as to both principal and interest at the corporate trust office of the Trustee under the applicable Supplemental Indenture. The Series 2021 Ball Park Bonds shall be issued in the denominations and numbers as requested by the Original Purchaser and approved by the Fiscal Officer, and shall be numbered as determined by the Fiscal Officer.

The principal of the Series 2021 Ball Park Bonds shall be payable at maturity of the Series 2021 Ball Park Bonds upon presentation and surrender to the Trustee. Interest on any Bond shall be paid on each Interest Payment Date as defined in and as further provided in the Sales Tax Revenue Bond Indenture. The principal and interest on the Series 2021 Ball Park Bonds is payable in lawful money of the United States of America without deduction for the services of the Trustee.

No Bond shall be valid or become obligatory for any purpose unless and until an authentication certificate appearing on the Series 2021 Ball Park Bond shall have been duly endorsed by the Trustee.

6. Book-Entry System. The Series 2021 Ball Park Bonds may be issued to a Depository for use in a book entry system and, if and as long as a book entry system is utilized: (i) the Series 2021 Ball Park Bonds of each series may be issued in the form of a single, fully registered bond representing each maturity and interest rate and Tax Status within a maturity and registered in the name of the Depository or its nominee, as registered owner, and immobilized in the custody of the Depository or its designated agent, which may be the Trustee; (ii) the beneficial owners of Series 2021 Ball Park Bonds in book entry form shall have no right to receive Series 2021 Ball Park Bonds in the form of physical securities or certificates; (iii) ownership of beneficial interests in Series 2021 Ball Park Bonds in book entry form shall be shown by book entry on the system maintained and operated by the Depository and its Participants, and transfers of the ownership of beneficial interests shall be made only by book entry by the Depository and its

Participants; (iv) the Series 2021 Ball Park Bonds as such shall not be transferable or exchangeable, except for transfer to another Depository or to another nominee of a Depository, without further action by the County, and (v) all the foregoing shall also be in accordance with the applicable Supplemental Indenture and, in the case of Series 2021 Ball Park Bonds, Section 9.96 and Chapter 133 of the Ohio Revised Code.

If any Depository determines not to continue to act as a Depository for the Series 2021 Ball Park Bonds for use in a book entry system, the County may attempt to establish a securities depository/book entry system relationship with another qualified Depository. If the County does not or is unable to do so, the County and the Trustee, after the Trustee has made provision for notification of the beneficial owners by the then Depository and any other arrangements deemed necessary, shall permit withdrawal of the Series 2021 Ball Park Bonds from the Depository, and shall cause Bond certificates in registered form to be authenticated by the Trustee and delivered to the assigns of the Depository or its nominee, all at the cost and expense (including costs of printing) of those persons requesting such issuance.

The County Executive and the Fiscal Officer are each authorized, to the extent necessary or required, to enter into any agreements, in the name and on behalf of the County, that that officer determines to be necessary in connection with a book entry system for the Series 2021 Ball Park Bonds, after determining that entering into those agreements will not endanger the funds or securities of the County.

7. Award and Sale of Bonds. The Series 2021 Ball Park Bonds shall be sold to the Original Purchaser at a purchase price and bearing interest at a rate or rates determined by the County Executive or the Fiscal Officer to be in the best interest of the County and as specified by the County Executive or the Fiscal Officer in the Certificate of Award in accordance with law, the provisions of this Resolution, and the applicable Supplemental Indenture. The County Executive or the Fiscal Officer, or both of them, shall sign the Certificate of Award evidencing that sale to the Original Purchaser, with the final purchase price, interest rate or rates, aggregate principal amount, principal amounts payable at each stated maturity, the amount of any capitalized interest, and Tax Status being set forth in the Certificate of Award and the applicable Supplemental Indenture, at a purchase price not less than 97% of par plus any accrued interest to their date of delivery. The Fiscal Officer may specify in the Certificate of Award whether any reserve fund shall be established for all or any of the Series 2021 Ball Park Bonds and, if so, the applicable reserve requirement (subject to any applicable federal tax law restrictions) and source of funding. The Fiscal Officer shall cause the Series 2021 Ball Park Bonds to be prepared, and have the Series 2021 Ball Park Bonds signed and delivered, together with a true transcript of proceedings with reference to the issuance of the Series 2021 Ball Park Bonds if requested by the Original Purchaser, to the Original Purchaser upon payment of the purchase price. The Fiscal Officer, the County Executive, the Director of Law, the Clerk of this Council and other County officials, as appropriate, are each authorized to sign any transcript certificates, financial statements and other documents and instruments and to take

such actions as are necessary or appropriate to consummate the transactions contemplated by this Resolution.

If, in the judgment of the Fiscal Officer, the filing of an application for (i) a rating on any Series 2021 Ball Park Bonds by one or more nationally-recognized rating agencies, or (ii) a policy of insurance or other credit enhancement facility from a company or companies to better assure the payment of principal of and interest on any Series 2021 Ball Park Bonds, or (iii) a surety bond or other credit enhancement facility from a company or other companies to satisfy any reserve requirement for any Series 2021 Ball Park Bonds is in the best interest of and financially advantageous to the County, the Fiscal Officer is authorized to prepare and submit those applications, to provide to each such agency, company or other credit enhancement facility provider such information as may be required for the purpose. The cost of obtaining each such rating, policy, bond or credit enhancement facility, except to the extent paid by the Original Purchaser, shall be paid from the proceeds of the Series 2021 Ball Park Bonds.

They Certificate of Award shall also specify the number of series in which the Series 2021 Ball Park Bonds will be issued and the designation of each. The Series 2021 Ball Park Bonds of each series shall conform to the limitations and requirements of this Resolution, and the Series 2021 Ball Park Bonds as a whole shall conform to the limitations and requirements of this Resolution.

The County Executive and the Fiscal Officer are, and each of them is, hereby authorized to execute and deliver, in the name and on behalf of the County, a Purchase Agreement for each series of Series 2021 Ball Park Bonds, with the Original Purchaser for that Series, dated as of a date to be specified in the Certificate of Award, incorporating or reflecting the Certificate of Award for that series and setting forth the terms and conditions for the sale and delivery of the Series 2021 Ball Park Bonds of that series to the Original Purchaser thereof, which the official or officials executing the Purchase Agreement and the Director of Law shall have determined to be consistent with the purposes and requirements of this Resolution and otherwise in the best interests of the County, all of which shall be conclusively evidenced by the signing of the Purchase Agreement by those officials.

If the Series 2021 Ball Park Bonds are issued in multiple series, then each series shall conform to all the restrictions and requirements specified in this Resolution and all of the Series 2021 Ball Park Bonds, in the aggregate, shall conform to the restrictions and requirements specified in this Resolution.

8. Application of Bond Proceeds. The proceeds of the sale of the Series 2021 Ball Park Bonds shall be allocated and deposited as provided in the applicable Supplemental Indenture.

9. Appointment of Bond Trustee; Indenture. The Certificate of Award shall also designate the financial institution (each of which shall have corporate trust powers in the State and such other qualifications as the County Executive or Fiscal Officer deems appropriate) to act as the trustee (each such trustee, or a successor trustee pursuant to the applicable Supplemental Indenture, the

“Trustee”) for the Series 2021 Ball Park Bonds or for any series thereof issued under a separate Indenture. The Fiscal Officer shall provide for the payment of the services rendered and for reimbursement of expenses incurred by the Trustee pursuant to the applicable Supplemental Indenture from the proceeds of the Series 2021 Ball Park Bonds to the extent available and then from other moneys lawfully available and appropriated or to be appropriated for that purpose.

In order to secure the Series 2021 Ball Park Bonds, the County Executive and the Fiscal Officer are, and each of them is, hereby authorized to execute and deliver, in the name and on behalf of the County, a trust indenture or supplemental trust indenture (each, an “Indenture”), each dated as of a date to be specified in the Certificate of Award, that the official or officials executing the Sales Tax Revenue Bond Indenture and the Director of Law have determined to be consistent with the purposes and requirements of this Resolution and otherwise in the best interests of the County, all of which shall be conclusively evidenced by the signing of the Indenture by those officials.

#### 10. Security for the Series 2021 Ball Park Bonds.

(a) Series 2021 Ball Park Bonds. The Series 2021 Ball Park Bonds are special obligations of the County, and the principal of and interest (and any premium) on the Series 2021 Ball Park Bonds are payable solely from the Pledged Sales Tax Revenues and the Pledged Sales Tax Revenue Bond Funds, together with other available funds of the County, and such payment is secured by a pledge of and a lien on the Pledged Sales Tax Revenues and the Pledged Sales Tax Revenue Bond Funds as provided in Chapter 133 of the Ohio Revised Code, this Resolution and the applicable Indenture.

The County has heretofore levied and covenants that it shall continue to collect the Original County Sales Tax for so long as the Series 2021 Ball Park Bonds are outstanding. The County hereby covenants and agrees that, so long as the Series 2021 Ball Park Bonds are outstanding, it shall not suffer the repeal, amendment or any other change in this Resolution or the County Sales Tax Resolutions that in any way materially and adversely affects or impairs (a) the sufficiency of the County Sales Tax Receipts levied and collected or otherwise available for the payment of the Series 2021 Ball Park Bonds or (b) the pledge or the application of the County Sales Tax Receipts to the payment of the Series 2021 Ball Park Bonds.

The Series 2021 Ball Park Bonds do not constitute a general obligation debt, or a pledge of the full faith and credit, of the State, the County, or any other political subdivision of the State, and the holders or owners of the Series 2021 Ball Park Bonds have no right to have taxes levied by the General Assembly or property taxes levied by the taxing authority of any political subdivision of the State, including the taxing authority of the County, for the payment of principal of and interest (and any premium) on the Series 2021 Ball Park Bonds. Nothing herein shall be construed as requiring the County to use or apply to the payment of principal of and interest (and any premium) on the Series 2021 Ball Park Bonds any funds or revenues from any source other than County Sales Tax Receipts.

Nothing herein, however, shall be deemed to prohibit the County, of its own volition, from using, to the extent that it is authorized by law to do so, any other resources for the fulfillment of any of the terms, conditions or obligations of this Resolution or of the Series 2021 Ball Park Bonds.

**11. Federal Tax Considerations. This Section 11 applies only to Series 2021 Ball Park Bonds that are Tax-Exempt Bonds.**

The County covenants that it will use, and will restrict the use and investment of, the proceeds of the Series 2021 Ball Park Bonds in such manner and to such extent as may be necessary so that (a) the Series 2021 Ball Park Bonds will not (i) constitute private activity bonds, arbitrage bonds or hedge bonds under Sections 141, 148 or 149 of the Code or (ii) be treated other than as bonds to which Section 103(a) of the Code applies, and (b) the interest on the Series 2021 Ball Park Bonds will not be treated as an item of tax preference under Section 57 of the Code.

The County further covenants that (a) it will take or cause to be taken such actions that may be required of it for the interest on the Series 2021 Ball Park Bonds to be and to remain excluded from gross income for federal income tax purposes, and (b) it will not take or authorize to be taken any actions that would adversely affect that exclusion, and (c) it, or persons acting for it, will, among other acts of compliance, (i) apply the proceeds of the Series 2021 Ball Park Bonds to the governmental purpose of the borrowing, (ii) restrict the yield on investment property acquired with those proceeds, (iii) make timely and adequate payments to the federal government, (iv) maintain books and records and make calculations and reports, and (v) refrain from certain uses of those proceeds, and, as applicable, of property financed with such proceeds, all in such manner and to the extent necessary to assure such exclusion of that interest under the Code.

The County Executive, the Fiscal Officer, or any other officer of the County having responsibility for issuance of the Series 2021 Ball Park Bonds is hereby authorized (a) to make or effect any election, selection, designation, choice, consent, approval, or waiver on behalf of the County with respect to the Series 2021 Ball Park Bonds as the County is permitted to or required to make or give under the federal income tax laws, including, without limitation thereto, any of the elections provided for in Section 148(f)(4)(C) of the Code or available under Section 148 of the Code, for the purpose of assuring, enhancing or protecting favorable tax treatment or status of the Series 2021 Ball Park Bonds or assisting compliance with requirements for that purpose, reducing the burden or expense of such compliance, reducing the rebate amount or payments or penalties, or making payments of special amounts in lieu of making computations to determine, or paying, excess earnings as rebate, or obviating those amounts or payments, as determined by that officer, which action shall be in writing and signed by the officer, (b) to take any and all other actions, make or obtain calculations, make payments, and make or give reports, covenants and certifications of and on behalf of the County, as may be appropriate to assure the exclusion of interest from gross income and the intended tax status of the Series 2021 Ball Park Bonds, and (c) to give one or more appropriate certificates of the County, for inclusion in the

transcript of proceedings for the Series 2021 Ball Park Bonds, setting forth the reasonable expectations of the County regarding the amount and use of all the proceeds of the Series 2021 Ball Park Bonds, the facts, circumstances and estimates on which they are based, and other facts and circumstances relevant to the tax treatment of the interest on and the tax status of the Series 2021 Ball Park Bonds. Notwithstanding the foregoing or any other provisions of this Resolution to the contrary, if the Fiscal Officer determines in the Certificate of Award that it is necessary and appropriate and in the best interests of the County for the interest on the Series 2021 Ball Park Bonds not to be excluded from gross income for federal income tax purposes, the County shall not be bound by the covenants of this Section.

12. Primary Offering Disclosure; Official Statement. The County Executive and the Fiscal Officer, in the name and on behalf of the County and in their official capacities, are authorized to (i) prepare or cause to be prepared, and to make or authorize modifications, completions or changes of or supplements to, a disclosure document in the form of one or more official statements in connection with the original issuance of the Series 2021 Ball Park Bonds, (ii) determine, and to certify or otherwise represent, when each official statement is to be “deemed final” (except for permitted omissions) by the County as of its date or is a final official statement for purposes of the Rule, (iii) use and distribute, or authorize the use and distribution of, the “deemed final” and final official statements and any supplements thereto in connection with the original issuance of the Series 2021 Ball Park Bonds, and (iv) complete and sign each final official statement as so approved, together with such certificates, statements or other documents in connection with the finality, accuracy and completeness of the “deemed final” and final official statements as they deem necessary and appropriate.

13. Continuing Disclosure. For the benefit of the holders and beneficial owners from time to time of the Series 2021 Ball Park Bonds, the County agrees to provide or cause to be provided such financial information and operating data, audited financial statements and notices of the occurrence of certain events, in such manner as may be required for purposes of the Rule. The County Executive and the Fiscal Officer are authorized to sign and deliver one or more continuing disclosure agreements (each, a “Continuing Disclosure Agreement”), setting forth the County's undertaking to provide such information and notices dated the date of delivery of the Series 2021 Ball Park Bonds and delivered to the Original Purchaser of the Series 2021 Ball Park Bonds. The County Executive and the Fiscal Officer are, and each of them is, hereby authorized to execute and deliver, in the name and on behalf of the County, each Continuing Disclosure Agreement that the official or officials executing the Continuing Disclosure Agreement and the Director of Law shall have determined to be consistent with the purposes and requirements of this Resolution and otherwise in the best interests of the County, all of which shall be conclusively evidenced by the signing of the Continuing Disclosure Agreement or Agreements by those officials.

14. Certification and Delivery of Resolution. The Clerk of this Council is directed to deliver or cause to be delivered a certified copy of this Resolution to the Fiscal Officer.

15. Satisfaction of Conditions for Bond Issuance. This Council determines that all acts and conditions necessary to be done or performed by the County or to have been met precedent to and in the issuing of the Series 2021 Ball Park Bonds in order to make them legal, valid and binding obligations of the County have been performed and have been met, or will at the time of delivery of the Series 2021 Ball Park Bonds have been performed and have been met, in regular and due form as required by law.

16. Other Documents. The County Executive, the Fiscal Officer, the Director of Law and the Clerk of Council are each hereby authorized to take any and all other actions and to execute any and all other instruments, certificates and documents as may in their judgment be necessary, desirable, advisable or appropriate in connection with the issuance of the Series 2021 Ball Park Bonds in order to give effect to the transactions contemplated to be performed on the part of the County under this Resolution, including, but not limited to, any cooperative agreement or other agreement anticipated to be with Gateway Economic Development Corporation of Greater Cleveland, the Team, the City of Cleveland and State of Ohio, related to the Project or to revenues that may be available for the Project or for payment of Bond Service Charges on the Series 2021 Ball Park Bonds that the official or officials executing such document and the Director of Law shall have determined to be consistent with the purposes and requirements of this Resolution and necessary and appropriate in connection with the issuance and delivery of the Series 2021 Ball Park Bonds and otherwise in the best interests of the County, all of which shall be conclusively evidenced by the signing thereof by those officials. To the extent an exemption from competitive bidding is needed for anything described herein, it is hereby granted.

17. Additional Transfers and Deposits. In connection with the financing of the Project, this Council hereby authorizes the Fiscal Officer to make deposits and transfers in the amounts described in the Cooperative Agreement, from the Cuyahoga County Excise Tax Facilities Improvement Fund, the Facilities Improvement Account, the County Account of the Sports Facility Improvement Fund, and the Sports Facility Reserve Fund, County bed tax collections, County excise tax collections, the County General Fund, and any other funds of the County that are available for such purpose, as further described in the Cooperative Agreement, to the Ball Park Improvement Fund, the Capital Repair Fund and certain other funds and accounts established under the Sales Tax Revenue Bond Indenture, all pursuant to the terms of the Cooperative Agreement, and hereby appropriates such funds for such purpose.

18. Bond Counsel. This Council hereby retains the legal services of Tucker Ellis LLP as bond counsel to the County, in connection with the authorization, sale, issuance and delivery of the Series 2021 Ball Park Bonds. In providing those legal services, as an independent contractor and in an attorney-client relationship, Bond Counsel shall not exercise any administrative discretion on behalf of the County in the formulation of public policy, expenditure of public funds, enforcement of laws, rules and regulations of the State, or of the County, or of any other political subdivision of the State, or the execution of public trusts.





First Reading/Referred to Committee: September 28, 2021  
Committee(s) Assigned: Committee of the Whole

Committee Report/Second Reading: October 26, 2021

Journal \_\_\_\_\_  
\_\_\_\_\_, 20\_\_

## TERM SHEET FOR CLEVELAND INDIANS LEASE EXTENSION

Cleveland Mayor Frank Jackson (the “City”), Cuyahoga County Executive Armond Budish (the “County”), Chairman Ken Silliman of the Gateway Economic Development Corporation of Greater Cleveland (“Gateway”), and Cleveland Indians Baseball Company, LLC Chairman and CEO Paul Dolan (the “Team”), collectively (the “Parties”) are committed to preserving Cleveland’s Major League Baseball franchise and its ballpark for future Northeast Ohio generations, and their desire to do so is reflected in the following terms for a lease extension. The Parties understand that the terms are subject to authorization by the respective legislative bodies and boards of each participating entity and subject to the execution of a mutually agreed amended and restated lease agreement (the “Lease”) incorporating, in part, the terms of this term sheet.

### **1. Term.**

There will be a 15-year lease term commencing January 1, 2022 and ending December 31, 2036. The lease will also contain one vesting option of either five or ten years as more fully described below.

### **2. Strategic Funding Approach**

Progressive Field (the “Ballpark”), since 1994, has served as the home of Major League Baseball in our community. The Parties are committed to preserving and improving our Ballpark, enabling it to continue to provide the outstanding fan and community experience it has provided since 1994.

To that end, the *public* financial contributions set forth below are confined to the repair, upkeep, and appropriate modernizations needed to protect and preserve a valuable asset in the City of Cleveland. The repair and upkeep is accomplished via Gateway’s payment of all capital repairs including minor and Major Capital Repairs (“Capital Repairs”) to the Ballpark, generally—but not exclusively—guided by a 20-year Facilities Condition Assessment (“FCA”) prepared by Gateway consultants with assistance from Gateway and which shall be regularly updated by Gateway and the Team. The modernizations are accomplished pursuant to a schedule of Ballpark improvements prepared by the Team and approved by the City and County, with the public providing 2/3 of the contributions toward an improvement fund solely dedicated to the modernization of the Ballpark (the “Ballpark Improvement Fund”).

By contrast to the public’s funding of the physical facility, the Team contributions are primarily directed to the operations required to field a Major League Baseball franchise and pay certain of the public’s operating expenses associated with the Ballpark, namely routine maintenance for the Ballpark, the approved operating budget of Gateway, an additional annual Team rent payment, and property taxes for the Ballpark itself. However, as described in Section 4 below, the Team has also agreed to contribute 1/3 of the funding for the Ballpark Improvement Fund, plus any cost overruns over the original funding amount.

**3. Funding Sources Table**

The County will cause these approximate one-time revenues to be deposited into the Ballpark Improvement Fund with final amounts determined at the time of deposit:

- \$5,250,000 from County’s General Fund;
- \$1,060,000 from 2020 County Bed Tax Collections (60% of 1.0% Bed Tax);
- \$2,250,000 from County Account of Sports Facility Reserve ();
- \$1,050,000 from 2021 County Bed Tax Collections (60% of 1.0% Bed Tax); and
- \$2,000,000 Payment to County from Development Parcel proceeds.

The existing balance in the 2015 Excise Tax Facility Improvement Fund estimated at \$3,400,000, the 2020 excess excise tax revenues, and the 2021 excess excise tax revenues will be deposited to the Capital Repair Fund at the time of funding the Ballpark Improvement Fund to fund existing approved capital repair obligations and 2022 projected Capital Repairs at the Ballpark.

The County will issue Bonds for the difference between \$135 million and the total of the above amounts, paid by the City, County and State of Ohio funding sources listed below. The Bonds will fund the public’s share of the Ballpark Improvement Fund costs. Any funds not required for Bond debt service payments will be allocated to the payment of Capital Repairs.

FUNDING SOURCE		NATURE: FIXED OR VARIABLE	ANNUAL \$ CONTRIBUTED*	DURATION
ENTITY	TYPE			
City	Sports Facility Reserve	Fixed	3,200,000	2024-2035
City	Parking Garage Revenue	Fixed	2,000,000	2022-2036
City	50% of Indians Admission Tax	Variable	2,550,000	2022-2036
City	Garage Naming Rights	Fixed	333,000	2022-2036
City	Unspecified	Fixed	350,000	2022-2036
County	Bed Tax Increment	Variable	3,000,000	2022-2036
County	Sin Tax	Variable	2,500,000	2021-2034
County	General Fund	Fixed	2,550,000	2022-2036
State of Ohio	Unspecified	Fixed	2,000,000	2022-2036
ANNUAL PUBLIC SECTOR CONTRIBUTION*			18,483,000	

\*Due to two of the funding sources not continuing for a full fifteen years, the annual total will be less in several of the years.

Collectively, the County one-time revenues and the City, County and State of Ohio annual payments shall comprise the “Estimated Public Annual Ballpark Contributions.” The Estimated Public Annual Ballpark Contributions are more fully set forth in the Ballpark Improvement Fund Public Resources & Capital Repair Deposits prepared by Stifel Nicolaus attached as Exhibit A.

In addition, the County will issue \$67.5 million of Bonds to be paid by the Team as the Team’s contribution to the Ballpark Improvement Fund pursuant to the Lease.

**4. Cost Sharing Table**

Gateway (using the Estimated Public Annual Ballpark Contributions set forth in Section 3) shall pay the Ballpark’s annual Capital Repairs, and Ballpark Improvement Fund expenses, and the Team shall pay Gateway operating expenses, Routine Maintenance, additional Team Rent, property taxes, and its share of Ballpark Improvement Fund costs, in the following estimated amounts:

EXPENSE ITEM	ESTIMATED ANNUAL COSTS IN \$	
	TEAM	GATEWAY
Routine Maintenance	2,200,000	0
Capital Repairs < \$500,000	0	2,000,000
Capital Repairs > \$500,000	0	4,670,000
Reserve fund for capital repairs	0	1,330,000
(Less Gateway Rent Credit)		(656,000)
Ballpark Improvement Fund		
Principal	4,500,000	9,000,000
Interest on County bonds	0	1,956,000
Interest on Team bonds	350,000	700,000
Gateway Operations	1,400,000	0
Additional Team Rent	656,000	
Gateway Property Taxes	1,100,000	0
<b>TOTAL ESTIMATED LEASE COSTS</b>	<b>10,206,000</b>	<b>19,000,000</b>

**5. Vesting Lease Options**

The Lease will contain one five-year vesting option to Gateway to extend the Lease subject to the conditions herein. The five-year vesting option will vest at the City’s and County’s option upon Gateway and the City and County demonstrating to the Team, on or before December 31, 2030, adequate and sufficient funding sources to account for an estimated \$9 million in annual Capital Repairs during years 16 through 20 of the option period and an additional \$67.5 million in Ballpark Improvement Funds to be contributed to the Ballpark Improvement Fund within one year of the public entities exercising the vesting option. If the public entities exercise the five-year vesting option as set forth herein, the Team agrees to contribute an additional \$33.75 million to the Ballpark Improvement Fund. Unless mutually agreed otherwise, an additional condition of the public exercising the

vesting option will be the provision by the public entities of private and public bond financing for the additional funds to be placed in the Ballpark Improvement Fund. The Team and the public will share in the interest costs for such financing on a 2/3 public – 1/3 Team basis. All other terms and conditions of the Lease shall remain the same during the extended Lease term.

The public entities shall also have the option to expand the term of the vesting option from five years to ten years, if Gateway, the City and County demonstrate, to the reasonable satisfaction of the Team, on or before December 31, 2031, sufficient funding sources that provide adequate funding for annual Capital Repairs and the Ballpark Improvement Fund to provide for the Ballpark's needs during the additional five year period, which if all Parties agree, shall add the 21st through 25<sup>th</sup> term years to the Lease.

### **6. Amended and Restated Lease**

The parties agree the Lease will contain the provisions set forth in this term sheet and replace the current lease between Gateway and the Team dated September 15, 2008 (the "Current Lease") and will also contain the following additional specific terms:

- (a) the definitions of Routine Maintenance, Capital Repairs, Major Capital Repairs, and Alterations in the Current Lease will remain unchanged in the Lease;
- (b) the Lease will incorporate language requiring annual review/revision of the FCA as needed by reason of the annual budget process and full updates to the FCA not later than 2025, 2028, 2031 and 2034;
- (c) Article V, "Term," shall be amended to incorporate the revised term and striking Section 5.2 "Extension Options" and replacing it with a new Section 5.2 entitled "Vested Lease Option;" and
- (d) the Lease will also be amended and supplemented as needed to provide for terms and provisions which the parties feel are appropriate to implement this term sheet or such other provisions deemed necessary and appropriate by Gateway and the Team.

### **7. Gateway East Garage.**

As set forth in Section 2, the City will contribute \$2 million annually from the operating revenue of the Gateway East Garage with the City covering any operating revenue deficiency sufficient to meet the \$2 million annual contribution. The City will also contribute \$333,000 in annual naming rights revenue with the City

covering any naming rights revenue deficiency sufficient to meet the \$333,000 annual contribution. For the next two years, the City will also make the Gateway East Garage available for the Team's purchase at a \$25 million purchase price. In the event the Team purchases the Gateway East Garage, the City will use the sale proceeds to fund the City's annual \$2 million commitment towards the Public's Ballpark Contributions and shall assign future naming rights sale proceeds to the Team as a 100% credit against the above-referenced \$333,000 annual payment.

### **8. Development Parcel**

Gateway agrees to convey or cause to be conveyed, the Gateway Development Parcel to the Team in exchange for a \$2 million purchase price. Gateway or its transferee will then convey its entire share of the sale proceeds into the Ballpark Improvement Fund.

### **9. Ballpark Improvement Fund Projects and Timeline**

The Ballpark Improvement Fund, held by the Trustee or Gateway, will be used to fund certain modernizations at the Ballpark to be overseen and disbursement to be approved by Gateway. These projects include, but are not limited to, an update and expansion of the Home Team Clubhouse to accommodate innovations in sports science and player training and treatment, a redesign and rebranding of the Terrace Club, and redesign of the right field upper deck and concourse. A complete copy of the projects to be financed with the Ballpark Improvement Fund and an estimated timeline for completion is attached hereto as Exhibit B. The Team agrees to fund any cost overruns to Ballpark Improvement Fund projects beyond the funding sources identified in Section 3 of this term sheet and the Team agrees to guarantee completion of the projects listed on Exhibit B.

*(Signatures Contained on Following Page)*

APPROVED BY:

---

Frank Jackson, Mayor, City of Cleveland

Date

---

Armond Budish, Cuyahoga County Executive

Date

---

Ken Silliman, Chairman, Gateway Economic Development  
Corporation of Greater Cleveland

Date

---

Paul Dolan, Chairman and CEO, Cleveland Indians  
Baseball Company, LLC

Date

# EXHIBIT A

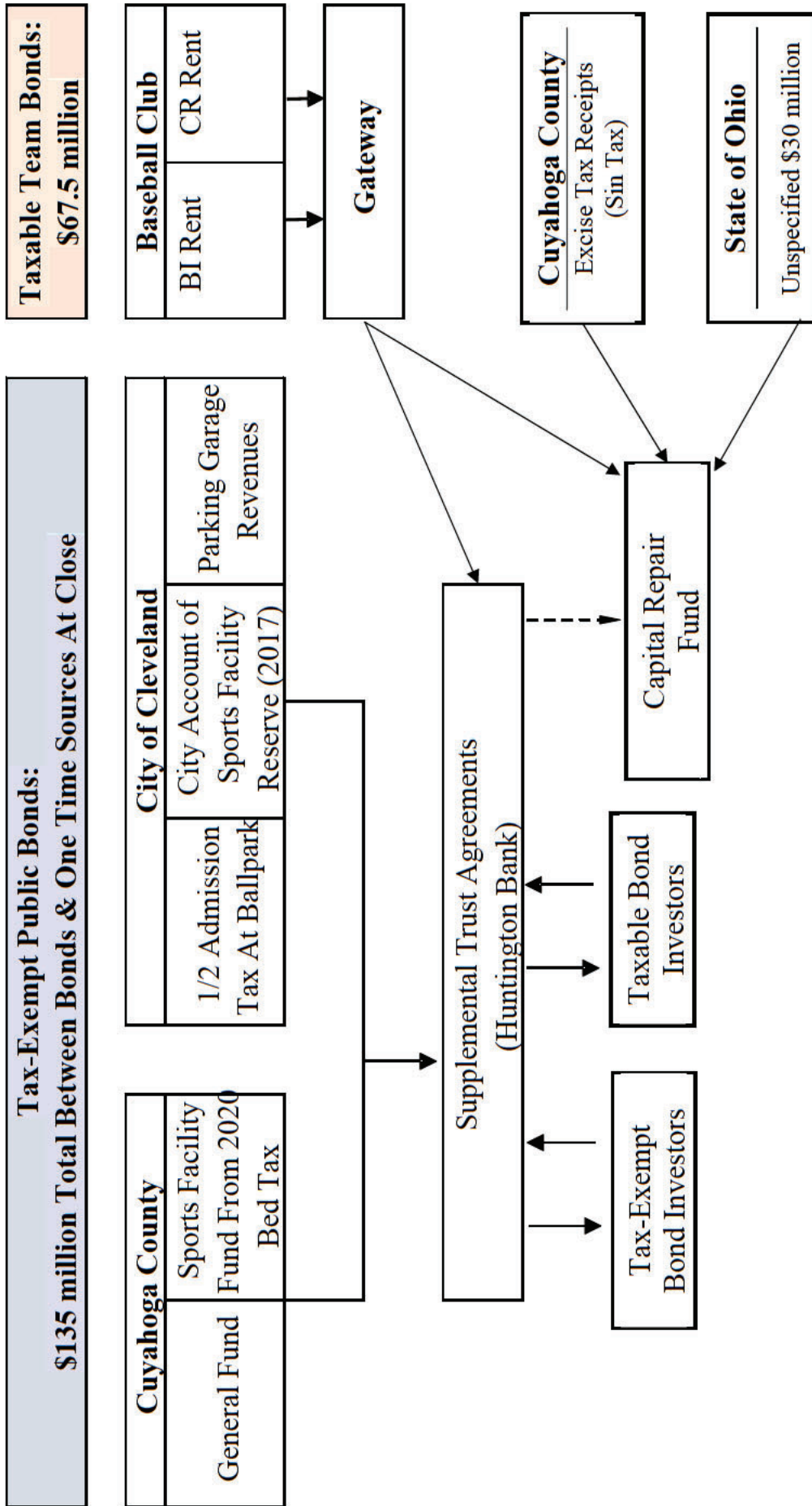



# EXHIBIT B

JULY 2021

BALLPARK IMPROVEMENTS



## Project Vision

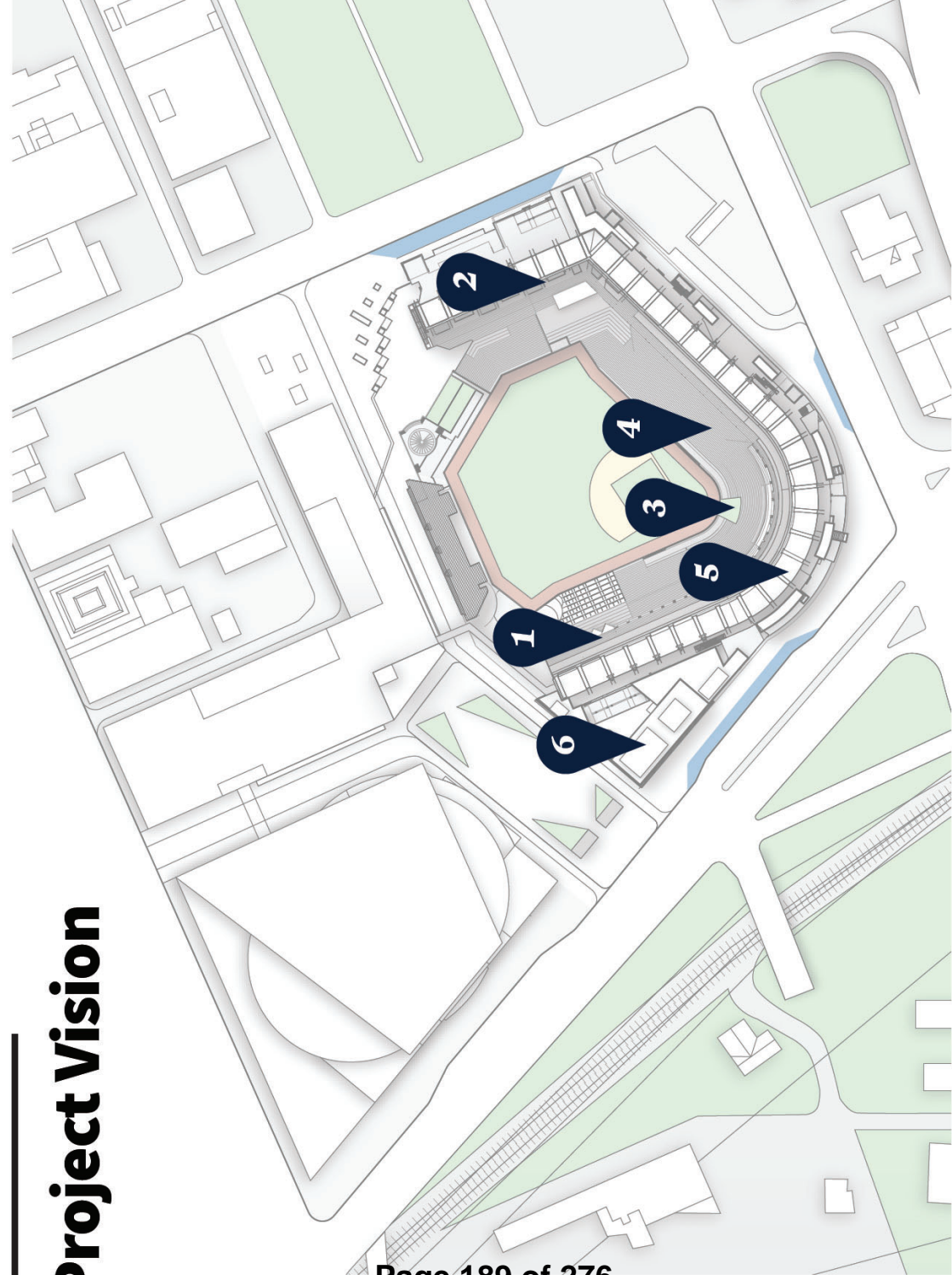

1

*Transformed Left Field Terraces*

2

*Upper Deck Re-imagined*

3

*Dugout Experience*

4

*Service Level & Clubhouse Modernization*

5

*Social Press Box Experience*

6

*Office Renovation & Connection to Gateway Plaza*

# Ballpark Improvement Projects

Project Cost Breakdown

*estimated cost*

Transformed Left Field Terraces	<b>\$33,000,000</b>
Upper Deck Re-Imagined	<b>\$40,000,000</b>
Dugout Experience	<b>\$9,000,000</b>
Service Level & Clubhouse Modernization	<b>\$40,150,000</b>
Social Press Box Experience	<b>\$20,000,000</b>
Office Renovation & Connection to Gateway Plaza	<b>\$42,000,000</b>
<b>Total</b>	<b>\$184,150,000</b>
<b>Escalation &amp; Contingency</b>	<b>\$18,415,000</b>
<b>Grand Total</b>	<b>\$202,565,000</b>

\$202.5M in Ballpark Improvements will be funded in a 2/3 (Public) 1/3 (Club) partnership.

The Club will be solely responsible for cost overruns on each project

Cost estimates have been created at Concept Phase and will be adjusted at completion of Schematic Design, Design Documentation and

Construction Documentation Phases for each project.

# Draft Proposed Phasing / Schedule

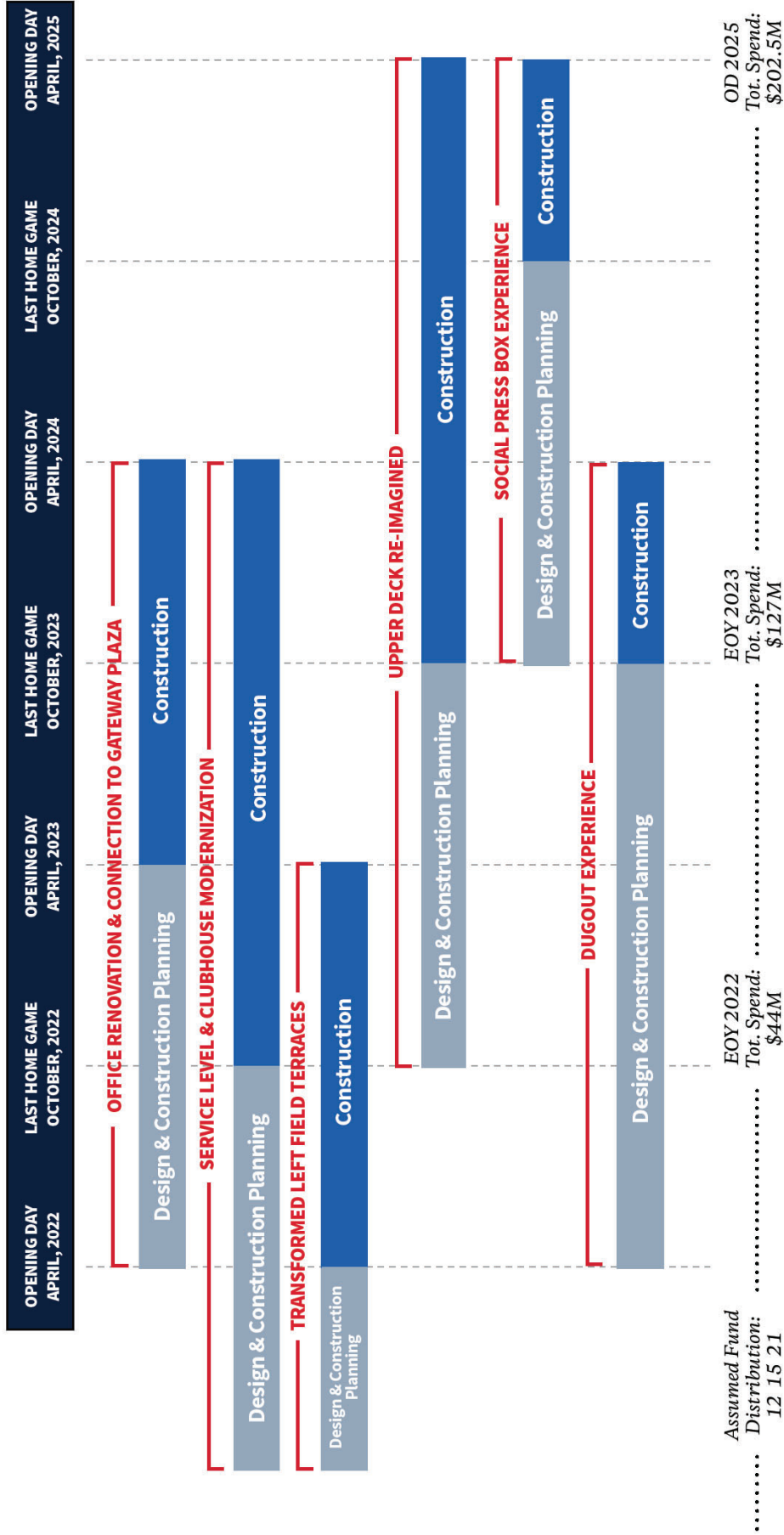

# County Council of Cuyahoga County, Ohio

## Ordinance No. O2021-0013

<b>Sponsored by: County Executive Budish/Department of Equity and Inclusion</b>	<b>An Ordinance</b> amending Chapter 503 of the Cuyahoga County Code: Small Business Enterprise Program Policies and Procedures to approve revised Cuyahoga County Small Business Enterprise Program Policies and Procedures, effective 11/15/2021 and adopt Minority Business Enterprise (MBE) & Women Business Enterprise (WBE) Program Policies and Procedures, effective 11/15/2021; and declaring the necessity that this Ordinance become immediately effective.
---	--

WHEREAS, the Cuyahoga County Executive/Department of Equity and Inclusion has submitted a revised Cuyahoga County Small Business Enterprise (SBE) Program Policies and Procedures Manual, effective TBD, and Minority Business Enterprise (MBE) & Women Business Enterprise (WBE) Program Policies and Procedures, effective 11/15/2021; and

WHEREAS, the Cuyahoga County Small Business Enterprise (SBE) Program Policies and Procedures Manual was previously adopted by Council in Ordinance No. O2011-0054, as amended by Ordinance No. O2014-0002, as codified in Chapter 503 of the Cuyahoga County Code; and,

WHEREAS, in 2020 the firm of Griffin & Strong conducted a disparity study, resulting in recommendations to the County, which are being implemented in the amendment to the SBE Program Policies and Procedures and the adoption of the MBE & WBE Program Policies and Procedures; and,

WHEREAS, it is necessary that this Ordinance become immediately effective in order that critical services provided by Cuyahoga County can continue and to provide for the usual, daily operation of a County entity.

**NOW, THEREFORE, BE IT ENACTED BY THE COUNTY COUNCIL OF CUYAHOGA COUNTY, OHIO:**

**SECTION 1.** Chapter 503 of the Cuyahoga County Code is hereby amended to read as follows:

**Section 503.01 Policies and Procedures Manual**

The revised Cuyahoga County Small Business Enterprise (SBE) Program Policies and Procedures Manual, attached to Ordinance No. O2021-0013 as Exhibit A, is hereby adopted effective 11/15/2021.

The Cuyahoga County Minority Business Enterprise (MBE) & Women Business Enterprise (WBE) Program Policies and Procedures Manual, attached to Ordinance No. O2021-0013 as Exhibit B, is hereby adopted effective 11/15/2021.

**SECTION 2.** Sections 503.03 through 503.05 are hereby removed. Sections 503.06, 503.07, and 503.08 are hereby renamed to 503.03, 503.04, and 503.05 respectively. Section 503.02 will remain unchanged.

**SECTION 3.** It is necessary that this Ordinance become immediately effective for the usual daily operation of the County; the preservation of public peace, health, or safety in the County; and any additional reasons set forth in the preamble. Provided that this Ordinance receives the affirmative vote of at least eight members of Council, it shall take effect and be in force immediately upon the earliest occurrence of any of the following: (1) its approval by the County Executive through signature, (2) the expiration of the time during which it may be disapproved by the County Executive under Section 3.10(6) of the Cuyahoga County Charter, or (3) its passage by at least eight members of Council after disapproval pursuant to Section 3.10(7) of the Cuyahoga County Charter. Otherwise, it shall take effect and be in force from and after the earliest period allowed by law.

**SECTION 4.** It is found and determined that all formal actions of this Council relating to the adoption of this Ordinance were adopted in an open meeting of the Council, and that all deliberations of this Council and of any of its committees that resulted in such formal action were in meetings open to the public, in compliance with all legal requirements, including Section 121.22 of the Ohio Revised Code.

On a motion by \_\_\_\_\_, seconded by \_\_\_\_\_, the foregoing Ordinance was duly adopted.

Yeas:

Nays:

\_\_\_\_\_  
County Council President

\_\_\_\_\_  
Date

\_\_\_\_\_  
County Executive

\_\_\_\_\_  
Date

\_\_\_\_\_  
Clerk of Council

\_\_\_\_\_  
Date

First Reading/Referred to Committee: August 3, 2021

Committee(s) Assigned: Public Works, Procurement & Contracting

Legislation Amended in Committee: October 20, 2021

Committee Report/Second Reading: October 26, 2021

Journal \_\_\_\_\_  
\_\_\_\_\_, 20



Exhibit A



COUNTY OF CUYAHOGA, OHIO

**SMALL BUSINESS ENTERPRISE (SBE) PROGRAM  
POLICIES AND PROCEDURES**

July 2021

# TABLE OF CONTENTS

I.	POLICY STATEMENT	2
II.	PROGRAM SCOPE AND APPLICABILITY	2
III.	THE DEPARTMENT OF EQUITY AND INCLUSION	3
IV.	CERTIFICATION	4
V.	ELIGIBILITY STANDARDS FOR SBE CERTIFICATION	4
VI.	OPERATIONAL CONTROL	6
VII.	MANAGERIAL CONTROL	6
VIII.	THE PURPOSE AND USE OF GOALS	7
IX.	WAIVERS AND WAIVER OF NON-COMPLIANCE WITH SBE GOAL	8
X.	REQUIREMENTS OF PRIME CONTRACTORS	9
XI.	GOOD FAITH EFFORTS	10
XII.	AWARD OF CONTRACTS	11
XIII.	MONITORING AND POST-AWARD REPORTING	12
XIV.	GRIEVANCE PROCESS	13
XV.	SANCTIONS AND PENALTIES FOR NON-COMPLIANCE	14
XVI.	TRAINING AND OUTREACH STRATEGIES	15
XVII.	BOND WAIVER PROGRAM	18
XVIII.	GRADUATION BY SBE PROGRAM PARTICIPANTS	18
XIX.	SEVERABILITY	18
XX.	DEFINITIONS	18

APPENDIX A CUYAHOGA COUNTY SBE BIDDER'S MANUAL



## I. POLICY STATEMENT

Policy Statement: It is the policy of Cuyahoga County to ensure that all businesses have the opportunity to participate fully and fairly in Cuyahoga County's procurement and contract awards.

In an effort to ameliorate the effects of past and present arbitrary barriers that small businesses have in contracting with Cuyahoga County, Cuyahoga County hereby adopts this Small Business Enterprise (SBE) Program to:

- promote and encourage full and open competition in the procurement of goods and services by Cuyahoga County;
- encourage all Cuyahoga County personnel involved with procurement and contracting activities to maintain good faith efforts and appropriate purchasing procedures; and
- protect Cuyahoga County from becoming a passive participant in any unlawful discrimination; and to otherwise spur economic development in the public and private sectors of the Cuyahoga County economy.

Moreover, no person shall be denied the benefit of, or otherwise discriminated against, on the basis of race, creed, color, national origin, handicap, sex, age, marital status, or sexual orientation in connection with the award or modification of a contract between a vendor or contractor and Cuyahoga County where said contract is paid for, in whole or in part, with monetary appropriations by Cuyahoga County.

## II. PROGRAM SCOPE AND APPLICABILITY

The following categories provide an overview and summary of the nature and types of Cuyahoga County purchasing and contracting:

Category A – Construction, Architectural and Engineering: Includes any and all contracting relating to horizontal and vertical construction including architectural engineering, new construction, rehabilitation, remodeling, and repairs.

Category B - Commodities: Includes the purchase of all goods, equipment, food, office and other supplies, art, furniture, textbooks and other materials for education, and other tangible personal property not associated with the services identified in Categories A, B or C.

Category C - Professional Services: Includes the purchase of any or all services for which applicable selection criteria may require a Participant to possess a license or other certificate of competency such as accounting, auditing, landscape architecture, engineering, insurance, laboratory, legal, lifeguard, medical, dental, nursing, and student transportation.

Category D – Business Services: Includes the procurement of advertising, printing, non-construction repairs, janitorial services, training seminars and workshops, computer and information systems, security, shipping and mailing, microfiche and microfilm, courier, storage, travel, consulting, retail, and other non-professional services.

### III. THE DEPARTMENT OF EQUITY AND INCLUSION

The Department of Equity and Inclusion (DEI) develops, administers, and enforces the SBE Program. DEI shall encourage equal business opportunities and achieve the policies and objectives of the SBE Program by:

- (1) Administering and enforcing Cuyahoga County policies;
- (2) Establishing written rules, regulations, and procedures consistent with the SBE Program;
- (3) Publishing and making public said rules, regulations, and procedures;
- (4) Maintaining outreach and assistance programs to promote equal contracting opportunities for SBE businesses that wish to contract with the Cuyahoga County and educating vendors and contractors on the SBE Program, SBE Goals, and Good Faith Efforts Criteria;
- (5) Establishing, enhancing, and maintaining relationships with agencies and stakeholders in the area;
- (6) Maintaining a current database of available SBEs and making this database accessible to interested parties;
- (7) Monitoring and collecting data and information on the utilization of SBEs in Cuyahoga County's procurement activities that allows a comprehensive review of the impact of the SBE Program;
- (8) Establishing and assessing the reasonableness of SBE participation goals for Cuyahoga County procurements;
- (9) Attending pre-bid/proposal conferences for all procurement solicitations by Cuyahoga County;
- (10) Attending kick-off meetings for major projects;
- (11) Participating on evaluation panels for request for proposals and requests for qualifications;
- (12) Investigating written complaints related to the SBE Program;
- (13) Mediating payment disputes between prime contractors and SBE sub-contractors
- (14) Notifying affected parties in writing as to the right to review and appeal an adverse decision by DEI;
- (15) Monitoring Cuyahoga County's purchasing activities and determining compliance with SBE program policies and procedures;
- (16) Preparing annual reports on the SBE Program;
- (17) Reviewing and determining whether a contractor or vendor has failed to implement its contractual agreements and commitments regarding this policy;
- (18) Developing and revising SBE Program policies and procedures to implement current best practices and maintaining records of SBE Program activities; and
- (19) Performing other tasks as may be required to fulfill the above-stated duties of DEI.

Authority to Investigate Discriminatory Practices: A Participant's written complaint of discrimination shall be forwarded to the Commission on Human Rights for investigation and determination under Title XV of the County Code. Further, such investigations may be initiated by referral to the Commission on Human Rights when DEI receives information, which provides a reasonable basis to believe that an individual contractor seeking to contract or contracting with Cuyahoga County may be engaging in public or private discriminatory conduct.

## IV. CERTIFICATION

Certification: Certification is the process that ensures that a particular business may become a part of a pool of vendors identified for the purpose of increasing opportunities with respect to contracts and purchases awarded by Cuyahoga County.

All firms submitting applications for SBE consideration must be certified prior to submission of a bid or proposal.

Applications for certification will be on standard forms provided by Cuyahoga County and will include, but will not be limited to, primary business location, evidence of ownership, control, operation, and experience. The application shall be in the form of an affidavit and shall be signed by the applicant; such signature to be notarized by an officer duly authorized to notarize signatures. All certified SBE firms will be required to update their listing continually including changes of addresses, telephone numbers and changes of ownership, control, and operation. In addition to the applications for certification, vendors seeking SBE certification shall also submit documentation demonstrating eligibility for certification, managerial control, and operational control. This documentation includes, but is not limited to, federal business tax returns, federal personal tax returns, proof of capital investment or contribution, corporate documents (i.e., Articles of Incorporation, Share Ledger, Corporate Bylaws...), bank signature card, current lease/rental agreement or property taxes for business location, business licenses, worker's compensation certificate and proof of identification for all who own 5% or more of the business.

The Director of DEI shall grant certification of an approved SBE Business for a period of two (2) years. The Director may grant a provisional certification prior to specific bids or proposals. All companies must recertify their business depending on the expiration date of their certificate which in most instances is the anniversary of their certification. Should provisional certification be granted to a business and that business be awarded a prime contract and the provisional certification is later rescinded, that business is obligated to meet the SBE participation percentage goal of the original proposal or specifications.

If a business is denied certification on the basis of information submitted, the company cannot reapply for certification for a period of one (1) year from the date of the notice or denial, provided that such company shall have the right to appeal such denial and to be certified if such appeal is decided in its favor as provided herein. Certification records will be maintained by DEI for a period of five (5) years.

## V. ELIGIBILITY STANDARDS FOR CERTIFICATION

The following standards will be used to determine whether a firm is eligible to be certified as a Small Business Enterprise:

1. To become eligible for the SBE Program, a business firm must demonstrate that it has been in continuous operation in the category or the related category for which it is requesting certification for one year and that majority ownership has at least one (1) year of work experience relevant to the business' certification category, and that its annual gross revenues or its' total workforce are at or less than the amounts established by the Small Business Administration.
2. A business applying for SBE certification must establish that it has a physical presence located within the geographical limits of Cuyahoga County. Mailbox facilities or other similar arrangements alone do not constitute a physical presence.

3. SBE ownership and control shall be real, substantial, and continuing and shall go beyond the “pro forma” ownership as reflected in the ownership document. The SBE owners shall share in the risks and profits commensurate with their ownership interest as demonstrated by an examination of the substance rather than form of arrangements.
4. SBE owners shall possess the power to direct or cause the direction of the management and policies of the firm and to make the day-to-day as well as major decisions on matters of management, policy, and operation. The firm shall not be subject to any formal or informal restrictions that limit the customary discretion of the SBE owners. There shall be no restrictions through, for example, by-law provisions, partnerships, arrangements, or charter requirements for cumulative voting rights or otherwise that prevent the business owners, without the cooperating or vote of any owner who is not listed, from making a business decision of the firm.
5. Where the actual management of the firm is contracted out to individuals other than the owner, those persons who have the ultimate power to hire and fire managers, for the purpose of this part, are deemed to be controlling the business.
6. All securities that constitute ownership and/or control of a corporation shall be held directly by the owners. No securities held in trust, or by any guardian for a minor, shall be considered as held by an owner in determining the ownership or control of a corporation. If a business denied certification due to securities held in trust appeals to and is granted a waiver of this eligibility requirement by the Grievance Hearing Board, then the waiver granted by the Grievance Hearing Board shall remain in effect for that business provided that the ownership structure remains unchanged.
7. The contribution of capital or expertise by the owners to acquire their interest in the firm shall be real and substantial. Examples of insufficient contributions include a promise to contribute capital, a note payable to firm, or the mere participation as an employee, rather than as a manager.
8. In addition to the above standards, special consideration shall be given to the following circumstances in determining eligibility for certification:
  - a. Newly formed firms and firms whose ownership and/or control has changed since the date of the advertisement of the contract are closely scrutinized to determine the reasons for the timing of the formation of or change in the firm.
  - b. A previous and/or continuing employer-employee relationship between or among present owners is carefully reviewed to ensure that the employee-owner has management responsibilities and capabilities discussed in this section.
  - c. Any relationship between a SBE and any other business which is not a SBE business or belonging to a non-SBE business, which has an interest in the SBE business is carefully reviewed to determine if the interest of the non- SBE business conflicts with the ownership and control requirements of this section.

## VI. OPERATIONAL CONTROL

DEI shall review the extent of “operational” control. The primary consideration in determining operational control and the extent to which the applicant actually operates the business will rest upon the peculiarities in the industry of which the business is a part. For example, for small contractors, it is reasonable to expect the applicant to be knowledgeable of all aspects of the business. This may not apply to large contractors who have the assets and personnel to specialize. Accordingly, in order to clarify the level of operational involvement,

which an applicant must have in a business for it to be considered eligible, the following criteria are put forth, but are not intended to be all inclusive.

1. The applicant should have some experience in the industry for which certification is being sought.
2. The applicant should show that basic decisions pertaining to the daily operations of business can be independently made. This means the applicant must possess the knowledge to weigh all advice given and to make an independent determination.
3. The applicant should have some technical competence in the industry in which certification is being sought. Technical competence in this sense does not mean expert knowledge. It does mean the applicant should have a working knowledge of the technical requirements of the business needed to operate in the industry.

## VII. MANAGERIAL CONTROL

DEI shall review the extent of “managerial” control. Managerial control means that the applicant has the demonstrable ability to make independent and unilateral business decisions needed to guide the future of the business. Managerial control may be demonstrated in many ways. For an applicant to demonstrate managerial control, the following criteria are put forth, but are not intended to be all-inclusive:

1. Articles of incorporation, corporate bylaws and partnership agreements or other agreements shall be free of restrictive language, which would dilute the applicant’s control, thereby preventing the applicant from making those decisions, which affect the future of the business.
2. The applicant shall be able to show clearly through production of documents the areas of applicant control, such as, but not limited to:
  - a) Authority and responsibility to initiate and sign checks, letters of credit, and loan agreements.
  - b) Authority to negotiate and signature authority for insurance and/or bonds.
  - c) Authority to negotiate for banking services.
  - d) Authority to hire and fire employees.
3. Agreements for support services that do not lessen the applicant’s control of the company are permitted as long as the applicant’s power to manage the company is not restricted or impaired.

## VIII. THE PURPOSE AND USE OF GOALS

Definition and Purpose: Cuyahoga County maintains a compelling interest in providing equal business opportunities for all persons wishing to do business with it. Therefore, DEI will continue to encourage, monitor, and track SBE business participation in the procurement process through the SBE participation goals. Goals are not quotas, but rather a method enabling Cuyahoga County to encourage and promote inclusion of SBEs in the procurement process.

Procedure for Establishing Overall Goals: Cuyahoga County has established an overall thirty percent (30%) subcontracting goal for SBE Participation in County procurements. If desired, Cuyahoga County may establish a revised overall SBE Participation Goal for Cuyahoga County. To establish a revised SBE overall goal, Cuyahoga County shall conduct an analysis of SBE participation in county purchasing activities. First, Cuyahoga County shall evaluate the levels of SBE participation for the Cuyahoga County overall procurement program for the previous year. As part of the review, Cuyahoga County may also consider data regarding SBE participation for the past three (3) fiscal years for a more accurate portrayal of SBE participation. Secondly, DEI shall review available SBE totals and percentages for the Cuyahoga County area. Based on the data, DEI shall make a recommendation for a revised overall SBE Participation Goal for review and approval by the County Executive and County Council.

Procedure for Establishing Individual Goals: To achieve the overall goal for SBE participation, the Director of DEI will establish SBE goals on a contract-by-contract basis based on an analysis of market availability and a commercially useful function within the contract. The Director of DEI may also waive the SBE goals for particular procurements as outlined in Section IX. (1).

Cuyahoga County will use the following criteria to determine the types of participation toward Cuyahoga County's overall annual SBE goals:

- 1) The total dollar value of the subcontract may be counted toward determining the specified goals. This includes the fees and commissions charged for professional services, legal counsel, manufacturers, financial consultants, and insurance agents.
- 2) Contract goals will be used to meet any portion of the annual goal. Contract goals are established so that, over the period to which the goal applies, they will cumulatively result in meeting any portion of the goal projected to be met through the use of the different programs.
- 3) Contract goals will only be established on those contracts that have subcontracting opportunities for SBE participation. The size of contract goals will be adapted to the circumstances of each contract (e.g., type and location of work, availability of the SBEs to perform the particular type of work) and functionality within the contract.

SBE Participation in Meeting Goals: All Participants, including SBE Participants, shall make good faith efforts to attain goals through all subcontractor work.

- (1) Prime Contractors: A Prime Contractor should subcontract portions of its contract consistent with industry standards. However, all SBE subcontractors must perform a commercially useful function as defined herein. Only such participation by an SBE will be counted towards any goal.
- (2) Subcontractor Participation: Where a Prime utilizes one or more subcontractors or 2<sup>nd</sup> tier subcontractors to attain a SBE goal, the Participant may only count said SBE subcontractor or sub-subcontractor work once toward goals. In no way shall subcontractors' or sub-subcontractors' work or dollar amount be construed to count toward said goal more than once. Only expenditures to SBE subcontractors that perform a commercially useful function in the work of that project or contract will be counted.
- (3) Supplier Participation: Where a Participant utilizes suppliers or distributors to satisfy the goal(s) in whole or in part, the SBE suppliers must perform a commercially useful function. Supplier participation may be approved upon review of the following factors:
  - i) The nature and amount of supplies to be furnished;



- ii) Whether the SBE is a manufacturer, wholesaler or distributor of the supplies and has the capabilities to deliver same in accordance with its certification;
- iii) Whether the SBE actually performs, manages, and supervises the work to furnish the supplies; and
- iv) Whether the SBE business intends to purchase supplies from a non-SBE and simply resell same to the general or prime contractor for allowing those supplies to be counted towards fulfillment of the goal(s). Participants will receive no credit for the dollar amount of the supply contracted from brokers.

## IX. WAIVERS AND WAIVER OF NON-COMPLIANCE WITH SBE GOAL

1. This SBE Program policy may be waived for the following:
  - a) “Sole Source” procurements under the Cuyahoga County ordinances which by their very nature limit the source of supply to one vendor.
  - b) County purchases from political subdivisions/government entities;
  - c) County purchases off state contracts, off federal contracts, and from joint purchasing programs;
  - d) The acquisition of any interest in real property including lease holdings;
  - e) Direct and indirect employee payments including payroll expenditures, pensions, and unemployment compensation and other employee-related expenditures;
  - f) Any other categories and subcategories of goods and services Cuyahoga County may from time to time establish as excluded contracts upon recommendation of the Director of the Department of Equity and Inclusion and approval by the Cuyahoga County Executive and Cuyahoga County Council;
  - g) Purchases and contracts being procured using Informal RFBs, RFPs, and RFQs (estimated total value \$1,000.01-\$49,999.99): As part of its solicitation process, the department shall also solicit bids/proposals from County certified SBEs when available. To determine SBE availability, at least two (2) business days in advance of the posting/advertisement period, the department shall check the list of County certified SBEs on the County’s website (<https://opd.cuyahogacounty.us/en-US/listing.aspx>) and/or contact the Department of Equity and Inclusion for a list of pertinent County certified SBEs. For these transactions, when the department solicits bids/proposal/qualifications through the vendor email notification system (currently the Infor Strategic Sourcing Module) in accordance with County Code Section 501.12 E, the department shall notify the pertinent available SBEs using the vendor email notification system of the purchasing and contracting opportunity. Also, if required, as part of the additional solicitation efforts, the department shall also notify the pertinent available SBEs.
  
2. Application for Waiver. If the Contractor, consultant, supplier, or vendor does not meet the project goals, the bidder or offer or may seek a partial or total waiver of the project goals. The application for waiver of all or part of the project goals shall include full documentary evidence of the Participant’s good faith efforts to meet the project goals and why the request for waiver should be granted. The application shall be notarized and submitted as a part of the bid or offer. Additional explanation, affidavits, exhibits or other materials may be required by the Diversity Program to substantiate good faith efforts. (See the Good Faith Effort Certification, SBE-3, 2 pages, in the attached Bidder’s Manual). Waivers may also be granted for an acceptable explanation as to why the goals should be waived.

3. Waiver for Detriment to Public Health, Safety or Financial Welfare. The Director of DEI may waive SBE Program goals if the same causes a detriment to public health, safety, or the financial welfare of the County. The SBE Program goals may also be waived in the event available SBEs provide price quotes which are unreasonably high in that they exceed competitive levels beyond amounts which can be attributed to cost, overhead and profit.

## X. REQUIREMENTS OF PRIME CONTRACTORS

In consideration of the right and privilege to submit a bid or proposal on construction projects and other contracts with Cuyahoga County, at the time of submitting a proposal or bid, each participant shall be required to present appropriate documentation. The documents described below must be completed and signed by each Participant before a proposal or bid can be considered responsive:

- 1) Covenant of Non-Discrimination: Each Participant must submit a duly executed and attested Covenant of Non-Discrimination (SBE-1, found in the attached Bidder's Manual). This written instrument shall contain promises, declarations and/or affirmations made by the Participant. The completed document must contain an original signature and date of signature.
- 2) SBE Subcontractor Participation Plan: Each Participant must submit a duly executed Subcontractor Participation Plan (SBE-2, found in the attached Bidder's Manual) for each SBE subcontractor proposed. Copies and/or facsimiles of SBE-2 submitted with bids/proposals are acceptable BUT all required signatures must be dated as indicated. Also, please note the following:
  - a) Certified SBEs who are bidding as prime contractors **MUST** complete and submit the top portion of Form SBE-2 to guarantee the 20% SBE credit.
  - b) SBEs with multiple geographical locations shall enter the address and contact information for the geographical locations eligible for Cuyahoga County certification on Form SBE-2.
  - c) Prime vendors are **PROHIBITED** from using SBE(s) with whom the prime vendor has a familial relationship, joint or co-ownership, common partners, officers, or a shareholder relationship to meet the SBE Participation Goal. Hence, on Cuyahoga County projects/contracts, any portion of work subcontracted to a SBE vendor by a prime vendor that meets the above-mentioned criteria will **NOT** count towards the achievement of the established SBE Participation Goals.

Use of 2<sup>nd</sup> Tier Subcontractors: In the event that a subcontractor portions out work and utilizes the services of a sub-subcontractor or vendor, the prime contractor shall be required to report this use to DEI. For reporting purposes, the prime contractor shall report statistical data for the sub-subcontractor or sub-vendor, including race, gender, business size, area of specialization, dollar value, description of services or products purchased, and contact information. No SBE subcontractor will be permitted to subcontract more than 25% of their subcontract work (based on dollar value) without prior approval by DEI.

Other Information and Data: DEI may request additional information and data prior to a contract award. This information may include, but is not limited to, information regarding business ownership of all subcontractors to be utilized on the project, all of which shall reflect the race, gender, location, size, and area of specialization and structure of the identified businesses.

---

**A PARTICIPANT'S FAILURE OR REFUSAL TO PROVIDE INFORMATION AND DATA  
REQUIRED BY THIS PROGRAM AND REQUESTED BY DEI SHALL SUBJECT THE  
PARTICIPANT TO HAVING A  
PROPOSAL OR BID DEEMED NON-RESPONSIVE.**

---



## XI. GOOD FAITH EFFORTS

Aggressive “Good Faith Efforts” to include SBEs in the procurement process are required of all Participants. These Good Faith Efforts should be in addition to the Participant’s regular and customary solicitation process of contact with potential subcontractors and/or vendors.

Written Notice to SBEs: To demonstrate good faith efforts, a Participant shall deliver written or electronic notice to potential SBEs. SBEs should be contacted not less than one (1) week before the bid or proposal due date. Names, addresses, and telephone numbers for available SBEs may be obtained by contacting DEI or reviewing the database on the website at <https://opd.cuyahogacounty.us/en-US/listing.aspx>.

The written or electronic notice sent to potential subcontractors or vendors shall contain the following:

- (1) Sufficient information about the plans, specifications, and relevant terms and conditions of the solicitation. This should include information about the work which will be subcontracted or the goods which will be obtained from subcontractors and suppliers;
- (2) A contact person knowledgeable of the project scope documents, within the Participant’s office, to answer questions about the conditions of the contract;
- (3) Information as to the Participant’s bonding requirements (including any offers to assist interested SBEs in obtaining bonding or insurance); and
- (4) The deadline for price quotations.

Evaluation of Good Faith Efforts: In evaluating good faith efforts, DEI will determine whether the Participant has made reasonable good faith efforts to obtain SBEs participation as part of its bid or proposal. DEI may evaluate not only the different kinds of efforts made by a Participant, but also the quantity and intensity of those efforts.

DEI will consider a completed Good Faith Effort Certification (SBE-3, 2 pages, found in the attached Bidder’s Manual), as evidence of a Participant’s good faith in trying to obtain SBE participation in a bid or proposal.

Required Documentation: To demonstrate good faith efforts, Participants shall keep detailed records of all correspondences and responses thereto, emails, logs of all telephone calls made and received regarding the project or contract, confirmation receipts for fax transmissions, receipts from registered or certified mail, copies of advertisements in publications and other media, and other relevant papers required by this Program.

Good Faith Effort Certification: Participant must submit a completed Good Faith Certification (SBE-3, found in the attached Bidder’s Manual) ONLY if the SBE Participation Goal is not met. The completed document must contain an original signature, notarizations, and date of signature. Along with the completed Good Faith Effort Certification, participants shall also submit additional documentation demonstrating a good faith effort (as detailed above in *Required Documentation*).

Administrative Reconsideration: If DEI determines that the apparent successful vendor is non-compliant on meeting the SBE participation goal and has not demonstrated good faith efforts to obtain SBE participation, prior to awarding the contract/purchase, the user department shall notify the apparent successful vendor of the determination of non-compliance by emailing the primary contact detailed in the vendor's bid/proposal. The apparent successful vendor shall have the right to request an administrative reconsideration of the non-compliance determination. The administrative reconsideration can be a "no meeting" reconsideration or "meeting" reconsideration (virtual or in-person). The request for an administrative reconsideration must be submitted within three (3) business days of the notification of non-compliance and in the format of an email to DEI at [dei@cuyahogacounty.us](mailto:dei@cuyahogacounty.us). Upon receipt of the request for the administrative reconsideration by the apparent successful vendor, DEI shall forward the request to the Administrative Reconsideration Panel. The panel shall consist of at least three (3) but not more than five (5) County employees appointed by the Cuyahoga County Executive. The request for administrative reconsideration shall detail the pertinent RFB/RFP/RFQ (i.e., title, description...), type of administrative reconsideration requested (i.e., no meeting or meeting), and any written documentation or arguments concerning the issue of non-compliance. DEI shall provide a summary of its Good Faith Effort evaluation and supporting documentation. The Administrative Reconsideration Panel shall publish a schedule that includes deadlines and provides for a frequency of no less than twice per calendar month. The Administrative Reconsideration Panel will evaluate the information provided by the apparent successful vendor and DEI and issue a written decision approving or disapproving of DEI's determination on non-compliance for the matter. A quorum for "no meeting" or "meeting" administrative reconsideration shall be the majority (i.e., greater than 50%) of the appointed panel and an affirmative vote by the majority (i.e., greater than 50%) of the panel present for the administrative reconsideration is required for action. The Administrative Reconsideration Panel shall adopt its own rules of procedure consistent with SBE Policies and Procedures. The result of the administrative reconsideration is not administratively appealable.

## XII. AWARD OF CONTRACTS

Award of Contract: Proposals/bids may be rejected and projects re-submitted for the sole purpose of attaining goals where no "good faith effort" has been demonstrated. Cuyahoga County reserves the right to determine the action to be taken on the contract if a goal is not met, including rejecting any or all bids or proposals. For RFPs and RFQs, once the scope of work and/or price, terms, and conditions have been finalized but in advance of submission for approval by the pertinent contracting authority, the department shall confirm with DEI that the proposed contract/purchase is compliant with the SBE participation goals and/or Good Faith Efforts requirements. If an awarded contract is later amended for additional dollars, SBE subcontractor participation should still reflect the percentage of dollars originally contracted for.

When evaluating a bid to determine the lowest and best bid, the County may consider, in addition to all of the other factors set forth in the instructions to bidders, whether a bid is SBE compliant; provided, however, that such SBE compliance shall not be considered if the difference between the SBE-compliant bid and the lowest responsive bid is more than the price preference specified below.

Lowest Bid Received Range (\$)	Price Preference (%) & Limit	Price Preference (\$)
0 – 500,000	10%	0 – 50,000
500,000.01 – 1,000,000	10% up to max \$80,000 (10-8)	50,000.01 – 80,000
1,000,000.01 – 3,000,000	8% up to max \$210,000 (8-7)	80,000.01 – 210,000
3,000,000.01 – 5,000,000	7% up to max \$250,000 (7-5)	210,000.01 – 250,000
>5,000,000	\$250,000 maximum (≤5)	250,000 maximum

### XIII. MONITORING AND POST-AWARD REPORTING

Department of Equity and Inclusion Authorization to Monitor: DEI shall be authorized to collect from all Participants such data and information as is necessary to monitor this Program. This information may include information as to business ownership, supplier information, subcontractor information, all of which shall reflect the contract information, race, gender, business location, and size of the identified businesses.

DEI shall monitor the participation of SBEs in the procurement of goods and services for Cuyahoga County. Such monitoring shall include, but is not necessarily limited to, a statistical analysis of each construction trade, business service, professional service, and commodity to determine whether there is utilization of SBEs in a manner that is proportionate to the established goal.

DEI will provide written reports on an annual basis. DEI’s report shall contain a summary of the purchases and contracts placed with SBEs for the period and the relative percentage to the total of purchases and contracts for that period.

Participant’s Post-Award Reporting: Participants who are awarded contracts must submit reports on a monthly basis during the course of, at the end of the contract, and as requested by DEI. Participants shall comply with all reporting requirements related to SBE utilization including, but not limited to, completing on-line reporting of payments made to SBE subcontractors and other subcontractors. These reports shall summarize the number and dollar amounts of payments made during the term of the contract to subcontractors. At the end of the contract, the final report shall summarize the number and dollar amounts of payments made during the term of the contract to all subcontractors and shall reflect the SBEs designation of the subcontractor if any. DEI reserves the right to audit a contract for SBE participation at its discretion during any phase of the project. An audit would include but not be limited to: on site reviews, desk reviews, requests for cancelled checks, requests for invoices, certified payroll reports, etc. Participants shall contact DEI if concerns arise related to its ability to meet the SBE goals and to seek guidance on available options to meet the goals.

SBE Subcontractor, Substitutions or Replacements: The prime contractor shall report any replacements or substitutions of the use of SBE subcontractors to DEI immediately. Prior approval by the Director of DEI is required for SBE substitutions/replacements. For reporting purposes, the prime contractor shall report to DEI statistical data pertaining to the new subcontractor, including race, gender, business size, area of specialization, and contact information on the SBE Subcontractor Participation Plan form (SBE-2).

DEI will require a Participant to make good faith efforts to replace a SBE that is terminated or has otherwise failed to complete its work on a contract with another SBE to the extent needed to meet the contract SBE Participation Goal. The Participant must notify DEI immediately, and in writing, of the SBE’s inability or unwillingness to perform and provide reasonable documentation. The request should include at a minimum: the name of the SBE firm, the contact, the phone number, the scope of work initially assigned to the SBE firm,

dollars paid to date, percent of scope completed, and the reason for the substitution request including documentation of the SBE's withdrawal.

The Participant will be given five (5) business days to find a SBE substitution if the request is granted. In this situation, the Participant will be required to obtain prior approval of the substitute SBE and to provide copies of SBE Subcontractor Participation Plan (SBE-2) or documentation of good faith efforts.

If the Participant fails or refuses to comply in the time specified, DEI may issue a recommendation to stop all or part of payment and/or work until satisfactory action has been taken. If the Participant still fails to comply, DEI may issue a recommendation of termination of the contract.

Contractors' Closeout Activity Reports: To further monitor SBE participation, closeout activity reports will be required from project prime contractors and prime consultants identifying activities of **all** subcontractors and sub-consultants (i.e., non-SBEs and SBEs). For all subcontractors and sub-consultants used, the prime contractor shall provide the following information: contact information, ethnicity/race/gender of ownership, summary of scope of work provided, and total payments for said scope of work. This report shall include all modifications/amendments/change orders. The prime contractors/consultants shall provide justification and documentation for SBE participation shortfalls.

## XIV. GRIEVANCE PROCESS

Any Participant or other party allegedly aggrieved by the provisions of this program may submit a written complaint to DEI who will notify the Grievance Hearing Board. The Grievance Hearing Board is empowered to hear all grievances concerning certification, de-certification, goal complaints, good faith efforts not previously reviewed by the Administrative Reconsideration Panel, and any other grievances called by the provisions of this program.

Grievance Hearing Board: The Grievance Hearing Board consists of the following five (5) members:

- Three (3) appointed by the County Executive, from time-to-time;
- Two (2) County Council Members appointed by the President of County Council

The Grievance Hearing Board meets as required to hear grievances pertaining to the SBE Program. A meeting quorum of this board consists of four (4) members. An affirmative vote by at least three (3) members is required for action items.

Request for Review: An allegedly aggrieved party may seek review of the DEI determination or decision by filing a written Request for Review with DEI within five (5) days of receipt of the Determination of Non-Compliance, certification denial, recertification denial, or other SBE decision.

Scheduling the Hearing/Notice of Hearing: Upon receipt of the request for review from the allegedly aggrieved party, DEI shall forward the request for review to the Grievance Hearing Board within three (3) business days of receipt and proceed with scheduling the hearing. Every effort shall be made to hold the hearing no more than twenty (20) days from the date of receipt of the request for review. All external parties shall be sent a written notice by registered mail which shall state the date, time, and place of the hearing.

Hearing: The hearings shall be informal. Participants shall include DEI and the allegedly aggrieved person(s), or a representative of the allegedly aggrieved person. Said hearing shall comply with State of Ohio law relative to the Open Meetings Act.

Decision: The Grievance Hearing Board shall issue a decision at the conclusion of the hearing which may approve or disapprove of DEI's decision or determination.

Exhaustion of Legal Remedies: An aggrieved person or entity must comply with the review process as outlined herein. Once a person or entity has exhausted the administrative remedies outlined in the Program, that person or entity may seek any other statutory, legal, or equitable remedies that may be available. Failure to exhaust all administrative remedies listed above is an affirmative defense to any statutory, legal, or equitable proceeding that may arise.

## XV. SANCTIONS AND PENALTIES FOR NON-COMPLIANCE

Cuyahoga County shall have the authority and power to enforce the provisions of this Program. Failure of a participant to comply with the requirements shall subject it to administrative sanctions. In addition, a violation of this Program shall constitute a material breach of contract enforceable at law or in equity, as will all other contract provisions, including the imposition of penalties. The following sanctions and penalties are established for the enforcement of this Program:

- (1) Determination of Non-Responsiveness: In addition to standard factors in its evaluation, Cuyahoga County may declare a bid or proposal non-responsive where it is determined that a Participant has not filed with Cuyahoga County a duly executed Covenant of Non-Discrimination or any other document as required by this Program.
- (2) Limited Suspension: For falsifications, misrepresentations, deception to obtain a contract, Cuyahoga County may remove a Participant from its list of eligible firms entitled to do business with Cuyahoga County.
- (3) Rejection of Future Proposals: Cuyahoga County may reject any or all future Proposals of a Participant until such time as the Participant demonstrates that it is or shall come into compliance.
- (4) Withholding Payment: Cuyahoga County may withhold payment, until such time as the Participant demonstrates that it is or shall come into compliance.
- (5) Cancellation of Contract: Cuyahoga County may declare a contract null and void where, after such contract has been awarded, an investigation determines that the Participant's documents contain false, fictitious, or fraudulent information.
- (6) Permanent Debarment: For repeated violations, Cuyahoga County may remove a Participant from its list of firms entitled to do business with Cuyahoga County indefinitely.

Guidelines for Imposition of Sanctions: The authority and power for imposition of sanctions and penalties shall lie with County authorities and elected/appointed officials as outlined in the County Charter, County Ordinances, state laws, and federal laws. The recommendation, however, may come from the Grievance Hearing Board or DEI.

- (1) General: Sanctions may be recommended if there is evidence of specific conduct on the part of the Participant that is inconsistent with or in direct opposition to the applicable provisions of this Program. Furthermore, the imposition and enforcement of sanctions shall be consistent with applicable County ordinances, state laws, and federal laws.



- (2) Severity of Sanctions: In determining the length of any suspension, Cuyahoga County shall consider the following factors:
- (i) Whether the failure to comply with applicable requirements involved intentional conduct or, alternatively, may be reasonably concluded to have resulted from a misunderstanding on the part of the Participant of the duties imposed on them by this Program;
  - (ii) The number of specific incidences of failure by the Participant to comply;
  - (iii) Whether the Participant has been previously suspended;
  - (iv) Whether the Participant has failed or refused to provide Cuyahoga County or DEI with any information required or requested by this Program;
  - (v) Whether the Participant has materially misrepresented any applicable facts in any filing or communication to Cuyahoga County or DEI; and
  - (vi) Whether any subsequent restructuring of the Participant's business or other action has been undertaken to cure the deficiencies in meeting applicable requirements.
- (3) Length of Suspension: Suspensions may be for any length of time. Cuyahoga County may impose suspensions in excess of one year in cases involving intentional or fraudulent misrepresentation or concealment of material facts, multiple acts in breach of the Program, cases where the Participant has been previously suspended, or other similarly situated misconduct.

Prohibition Against False Statements: It shall be unlawful for any person, knowingly and willfully and with intent to mislead or to make any false or fraudulent representations to Cuyahoga County. Cuyahoga County may impose sanctions against any person making such false representation in connection with the SBE Program.

## XVI. TRAINING AND OUTREACH STRATEGIES

Training: Cuyahoga County remains committed to implementing a program that increases the participation of SBEs in Cuyahoga County's procurement opportunities. To ensure that all Cuyahoga County employees involved in purchasing decisions are appropriately informed, certain personnel would undergo training to increase sensitivity regarding the utilization of SBEs. Internal training shall ensure that all staff with purchasing authority have the capacity and capability to engage in a consistent, fair, and open procurement process. Training sessions shall occur periodically. The objective of the training is to effectively communicate the importance of the Program and the mechanics of how the Program operates. The training shall address the following topics, among others:

- (i) Understanding the purpose of the Program.
- (ii) Understanding the benefits of doing business with SBEs.
- (iii) Understanding how the Program is administered.
- (iv) Developing innovative techniques to increase SBE participation.

Outreach Program: To ensure that opportunities to participate in Cuyahoga County’s contracts are available to the widest feasible universe of willing, available, and qualified businesses, DEI shall develop and engage in outreach designed to increase public awareness of the SBE Program, SBE Participation Goals, and SBE Good Faith Effort Criteria. This outreach may consist of any of the following:

- (1) Public Awareness of the Program. To increase the visibility of DEI and to increase the awareness of the Program, DEI shall disseminate at community events, trade shows, and other appropriate business functions, and publish on its website information describing the Program. Any Program updates shall be published within five (5) business days. This information shall also identify ongoing contracting opportunities. DEI will actively participate in the various advocacy groups to provide constant feedback and to keep SBEs abreast of the Programs and contracting opportunities.
- (2) Outreach to Contractors and Vendors. DEI shall conduct outreach to vendors and contractors desiring to do business with Cuyahoga County. The intent of this outreach is to support the SBE Program and promote effective procurement by educating businesses on the SBE Program, SBE Goals, and SBE Good Faith Efforts Criteria
- (3) Outreach to SBEs. DEI shall assist the SBE businesses by providing workshops and seminars on the SBE Program, SBE Goals, SBE Good Faith Efforts Criteria, and Cuyahoga County’s procurement policies and procedures.
- (4) 24-month Purchasing and Contracting Forecast. DEI shall work with Cuyahoga County departments and agencies to prepare and update biannually a 24-month purchasing and contracting forecasts (including annually reoccurring purchases). For the initial forecast and each biannual update of the forecast, County departments/agencies shall compile a purchasing and contracting forecast for the upcoming 24-month period and submit said forecast to DEI. The forecast shall include for each item the originating/lead department, a brief description, estimated amount, and estimated solicitation/advertisement date. The forecast shall also detail purchases and/or contracts that will be procured using the Small Business Set Aside Program which enables County certified small business enterprises to compete against each other for the item award. DEI shall combine the individual forecasts into one forecast and post the combined forecast on the DEI website biannually.

In addition, County departments and agencies shall coordinate with DEI to expand the Small Business Set Aside Program. Specifically, as part of the creation and biannual updates of their forecasts, County departments and agencies shall provide a forecast of contracts and purchases that will be procured using the Small Business Set Aside Program. The County departments and agencies and DEI shall use the following criteria to evaluate and select the contracts and purchases for procurement using the Small Business Set Aside Program:

<b>SELECTION CRITERIA</b>	<b>SUMMARY</b>
<b>FUNDING SOURCE REQUIREMENTS &amp; RESTRICTIONS</b>	County agencies leverage County funds with a multitude of other funding sources (i.e., federal, state, grants, loans...). This enables the County to maximize the return on its investments. However, some of the funding sources may have requirements that will limit the County's ability to fully enact its diversity/inclusion initiatives. When evaluating the eligibility of contracts or services for the SBE Set Aside Program, funding source requirements and restrictions will be assessed.
<b>SCOPE OF WORK</b>	When evaluating the eligibility of contracts or services for the SBE Set Aside Program, the scope of work will be assessed. Contracts or services selected will: <ul style="list-style-type: none"> <li>• be typical of the industry in size and scope</li> <li>• be of simpler or of typical complexity</li> <li>• have typical/standard delivery requirements</li> <li>• have typical periods of performance for the industry</li> </ul>
<b>COMPETITIVE ENVIRONMENT</b>	While providing opportunities for SBE vendors to participate in the County procurement process, the County must still maximize the return on its resources. As such, when evaluating the eligibility of contracts or services for the SBE Set Aside Program, at the time of selection, contracts or services must have at least three (3) County certified SBE vendors that provide the scope of work/goods being procured. The size of the pool of pertinent County certified SBE vendors will be re-confirmed at the time of advertisement.
<b>PERFORMANCE BOND AND INSURANCE REQUIREMENTS</b>	Performance bond and insurance requirements are frequently mentioned as obstacles to small businesses in participating in government contracts. When evaluating the eligibility of contracts or services for the SBE Set Aside Program, contracts, or services with lower than or typical performance bond and insurance requirements will be selected.

- (5) 30-day minimum Bid/RFP/RFQ Solicitation/Advertisement Period. All reasonable efforts shall be made to post formal bids/RFPs/RFQs for goods and/or services on the County website for no fewer than 30 days prior to the bid/RFP/RFQ opening. Reasonable efforts include, but are not limited to, County departments and agencies initiating the procurement process for bids, RFPs, and RFQs in ample time to complete pre-advertisement tasks (includes completion of procurement specifications, developing estimated costs by NIGP code for the pertinent scopes of work for the procurement, determination of diversity goals by DEI, finalizing the specification packet...) to enable the posting of bids, RFPs, and RFQs for no fewer than 30 days prior to the bid/RFP/RFQ opening date. Furthermore, reasonable efforts include, but are not limited to, County departments and agencies exhausting other options (such as working to accelerate the internal bid/proposal/qualification review process and contract negotiation) to meet contract and purchase award deadlines before shortening the solicitation/advertisement period. In brief, shortening the solicitation/advertisement period to less than 30 days shall not be the default, initial, or only option evaluated and/or exercised to accelerate the procurement timeline.



## XVII. BOND WAIVER PROGRAM

Cuyahoga County's Department of Law's Risk Management Division administers a bond waiver program in accordance with County Code Section 508.02.

## XVIII. GRADUATION BY SBE PROGRAM PARTICIPANTS

If a certified and otherwise eligible SBE achieves annual gross revenues or similar indicators of business size for three (3) consecutive years in its respective industry in excess of the pertinent SBA Size Standards for its certification category, then it shall be deemed to have overcome the effects of size and to have reached a competitive status in the marketplace. Upon achievement of such status, said firm(s) shall be graduated from the program and shall thereafter be ineligible for utilization to fulfill enforceable SBE Program participation goals. A graduated SBE may not subsequently re-enter the program unless, after the expiration of two calendar years, the SBE demonstrates:

1. that its annual gross receipts have declined to levels below those as set forth above and;
2. that during said two calendar years it was unable to achieve meaningful participation in Cuyahoga County contracts and/or in the public and private sectors of the larger local economy despite its good faith efforts to do so.

## XIX. SEVERABILITY

If any of the provisions set forth in this Program or any section, subsection, paragraph, sentence, clause, phrase, or word thereof shall be found to be invalid, illegal, or unenforceable for any reason, the application of the remainder of this Program shall not be affected by such invalidity.

## XX. DEFINITIONS

For the purpose of this Program, the following words, terms, phrases, and abbreviations shall have the following meanings:

“Administrative Reconsideration Panel”: shall mean the panel of County employees appointed by the County Executive that at the request of the apparent successful vendor reviews a non-compliance determination made by DEI.

“Certification”: shall mean the qualifying process that ensures buyers and local, state, and federal agencies that a particular business is eligible to become a part of a pool of vendors identified for the purpose of increasing opportunities with respect to contracts and purchases awarded by Cuyahoga County.

“Commercially Useful Function”: shall mean the performance of real and actual services by a Participant who contracts with Cuyahoga County, or subcontracts with another business enterprise which contracts with Cuyahoga County. A business enterprise serving as a “conduit”, “front” or “pass-through” for another business shall not be deemed to perform a commercially useful function. In determining whether a business is

performing a commercially useful function, factors, including but not limited to the following, will be considered:

- i) The nature and amount of work contracted;
- ii) Whether the SBE has the skill and expertise to perform work for which it has been certified;
- iii) Whether the SBE actually performs, manages, and supervises the work;
- iv) Whether the SBE intends to purchase commodities and/or services from a non-SBE and simply resell same to the general or prime contractor for the purpose of allowing those commodities and/or services to be counted towards the fulfillment of a goal;
- v) Standard industry practices relating to the use of the subcontractors. Consistent with standard industry practices, a SBE subcontractor may enter into second tier subcontracts. If a SBE subcontractor subcontracts a significantly greater portion of the work of its subcontract to a non-SBE inconsistent with standard industry practices, the SBE subcontractor shall be presumed not to be performing a commercially useful function.

“Compliance”: shall mean the condition existing when a Participant has met the requirements of this Program.

“Conduit”: shall mean a business which purchases goods or services that are not normally purchased or sold as part of its daily business from another business(es) for the sole purpose of resale to Cuyahoga County or a contractor doing business with Cuyahoga County.

“Contract”: shall mean any mutually binding legal obligation of Cuyahoga County created to acquire some good and/or service from one or more Participants, which is paid or which is to be paid for, in whole or in part, with monetary appropriations of Cuyahoga County. In this context, the terms “contracting”, “purchasing”, and “procurement” are synonymous and refer to the process or processes under which Cuyahoga County undertakes such acquisitions.

“Cuyahoga County”: shall mean the government agency which provides public contracting to increase quality of life in the County.

“Covenant of Non-Discrimination”: shall mean, collectively, one or more contractual affirmative promises (1) to adopt the policies of Cuyahoga County relating to the participation of SBEs in the procurement process; (2) to undertake certain good faith efforts to solicit SBEs participation; and (3) not to otherwise engage in discriminatory conduct against SBEs.

“DEI”: shall mean the Department of Equity and Inclusion, which is responsible for administration of the SBE Program.

“Department”: Shall mean a department, division or elected official’s office which solicits bids and/or proposals through the Purchasing Department.

“Goal”: shall mean an aspirational effort to attain a certain level of SBE participation on contracts awarded by the Cuyahoga County based on subcontracting opportunities and available SBEs to perform.

“Good Faith Efforts”: shall mean the aggressive actions of a Participant undertaken in earnest to achieve a SBE goal and ensure that it does not discriminate in its contracting practices.

“Independent”: shall mean that with respect to the ownership, control, and activity of a SBE, the business shall operate separate and apart from the ownership, control or undue influence of another business owned and controlled by one or more non-SBEs.

“Joint Venture”: shall mean an association of two or more independent persons, partnerships, corporations (or any combination of them) formed, consistent with the laws of the State of Ohio. This joint venture would carry out a single, for-profit business enterprise, for which the parties combine their property, capital, efforts, skills, and knowledge, and in which the SBE is responsible for a distinct, clearly defined portion of the work of the contract and whose share in the capital contribution, control, management, risks, and profits of the joint venture are commensurate with its ownership interest.

“Minority Business Enterprise” (“MBE”): shall mean an individual, domestic corporation, sole proprietorship, partnership, joint venture, entity, or company that is at least 51% owned by one or more individuals who are African American, Hispanic American, Native American, Asian-Pacific American, or Asian-Indian American; and whose management and daily business operations are controlled by one or more of these owners as determined by DEI.

“Manufacturer”: shall mean an individual (or individuals) who owns, operates, or maintains a factory or establishment that produces on the premises the components, materials, or supplies obtained by the Participant or Cuyahoga County.

“Non-Compliance”: shall mean the condition that exists when a Participant has failed to meet the requirements of this Program.

“Office”: shall mean that a business enterprise with an established place of business in the Cuyahoga County area at which one or more of its employees is regularly based and that such place of business has a substantial role in the business’ performance of a commercially useful function as herein defined. A location utilized solely as a post office box, mail drop or telephone message center or any combination thereof, with no other substantial work function, shall not constitute a significant business presence.

“Participant”: shall mean any contractor, vendor, supplier, or other person, partnership, joint venture, corporation, or other business entity that submits a bid or proposal to Cuyahoga County or expressed interest in submitting a bid or proposal in response to competitive solicitation issued by Cuyahoga County or who has been awarded a contract by Cuyahoga County.

“Project Owner”: shall mean the representative of Cuyahoga County that enters into agreement or contracts with a firm for services or supplies or any other item which shall cause a disbursement of funds from Cuyahoga County.

“Proposal”: shall mean a quotation, proposal, bid or offer by a Participant to perform or provide labor, materials, supplies, or services to Cuyahoga County in response to competitive solicitation issued by Cuyahoga County.

“Purchasing Department”: shall mean the Cuyahoga County department responsible for the purchase of goods and services required for all offices of Cuyahoga County, other than separate political subdivisions.

“Race/Gender-Conscious”: shall mean any governmental or legislative policy or programmatic action that uses race or gender as criteria for participation. The use of a MBE or WBE goal is a primary example of a race-conscious measure.

“Race/Gender-Neutral”: shall mean any governmental or legislative policy or a programmatic action in which race or gender is not among, or the specific criteria for participation. While benefiting MBEs and WBEs, it is

not solely focused on MBE or WBE firms and can be used to assist all small businesses. For example, small business outreach programs, technical assistance programs, mobilization fees, bonding assistance and prompt payment provisions can assist a wide variety of small businesses, not just MBEs and WBEs.

“Responsible”: shall reference a Participant’s integrity, compliance with public policy, and record of past performance and financial and technical resources. A Participant must meet certain requirements to be considered a responsible bidder.

“Responsive”: shall mean that a bid must comply in all material respects, both to the method and timeliness of submission and to the substance of any resulting contract, so that all Participants may stand on an equal footing and the integrity of the competitive bidding system may be maintained.

“Small Business Enterprise” (“SBE”): shall refer to a firm that is certified by DEI, submitted an application and has been accepted as a firm eligible to take advantage of affirmative action efforts established in the Small Business Enterprise Program.

“Underutilization”: shall mean the percentage of dollars spent by Cuyahoga County with SBEs which is less than would be expected based on SBE availability in the County.

“Women Business Enterprise” (“WBE”): means an individual, domestic corporation, sole proprietorship, partnership, joint venture, entity, or company that is at least 51% owned by one or more women and whose management and daily business operations are controlled by one or more of these owners as determined by DEI.

DRAFT



**RQ**

**BIDDERS' MANUAL**

**Small Business Enterprise (SBE) Program**

The goal of the SBE Program is to support and encourage inclusion by creating positive partnerships in County contracting and other procurement opportunities. The SBE Program will achieve this goal by providing and supporting opportunities for SBEs to grow and thereby compete effectively in the general environment for contracting opportunities.

THE SBE SUBCONTRACTOR PARTICIPATION GOAL  
FOR THIS BID/PROPOSAL IS

**{ENTER SBE %} %**

**OF THE CONTRACT AWARD**

Cuyahoga County  
Is an Equal Opportunity Employer

## TABLE OF CONTENTS

Section I.	SBE Certifications	Page 3
Section II.	SBE Set Aside Program	Page 3
Section III.	SBE Participation Goal	Page 3
Section IV.	Mandatory Bidding Requirements for Prime Contractors	Page 4
Section V.	Good Faith Efforts	Page 5
Section VI.	Award of Contracts	Page 6
Section VII.	Monitoring and Post-Award Reporting	Page 7

### REQUIRED FORMS:

- Covenant of Non-Discrimination (SBE-1)
- SBE Subcontractor Participation Plan (SBE-2)
- Good Faith Effort Certification (SBE-3, 2 pages)
- Sample of Completed SBE forms (4 pages)

# **INSTRUCTIONS TO BIDDERS**

## **I. SBE Certifications**

Only those certified by the Cuyahoga County's Department of Equity and Inclusion (DEI) shall be eligible for the fulfillment of the SBE participation goal. SBE listings may be obtained from the Department of Equity and Inclusion (DEI). If a SBE elects to compete for County business without being certified by Cuyahoga County as such, they may do so, but any bid/proposal submitted will not be counted towards fulfillment of the SBE participation goal.

A SBE desiring certification with Cuyahoga County must complete the certification application. SBE applications may be obtained from the:

Department of Equity and Inclusion  
2079 East Ninth St., 2<sup>nd</sup> Floor  
Cleveland, Ohio 44115  
(216) 443-7230

## **II. SBE Set Aside Program**

The goal of the Small Business Enterprise Set Aside Program is to support small businesses by creating contracts and other procurement opportunities exclusively for participation by Cuyahoga County Certified small business enterprise. The Small Business Enterprise Set Aside Program will achieve and support opportunities for small firms to grow and thereby compete effectively in the general environment for contracting opportunities. This program may also include MBE/WBE goals.

## **III. SBE Participation Goal**

The SBE Participation goal can be achieved in the following manner(s):

1. A prime vendor subcontracts with one or more certified SBEs to meet or exceed the goal;
2. A prime vendor subcontracts with one or more certified companies in an amount short of the goal, but submits a complete Good Faith Effort (further described below);
3. A certified SBE company who bids as a prime contractor subcontracts a portion of the work to another certified SBE. Certified SBEs who are bidding as prime contractors will receive a credit for up to 20% of the SBE participation goal. However, the certified SBE must secure additional certified SBE subcontractor participation and/or seek a waiver based on Good Faith Effort (further described below) for any remaining balance of the SBE goal.

## **IV. Mandatory Bidding Requirements for Prime Contractors**

In consideration of the right and privilege to submit a bid or proposal on construction projects and other contracts with Cuyahoga County, at the time of submitting a proposal or bid, each participant shall be required to present appropriate documentation. The documents described below must be completed and signed by each Participant before a proposal or bid can be considered responsive:

- 1) **Covenant of Non-Discrimination**: Each Participant must submit a duly executed and attested Covenant of Non-Discrimination (SBE-1, found in the attached Bidder's Manual). This written instrument shall contain promises, declarations and/or affirmations made by the Participant. The completed document must contain an original signature and date of signature.
- 2) **SBE Subcontractor Participation Plan**: Each Participant must submit a duly executed Subcontractor Participation Plan (SBE-2, found in the attached Bidder's Manual) for each SBE subcontractor proposed. Copies and/or facsimiles of SBE-2 submitted with bids/proposals are acceptable BUT all required signatures must be dated as indicated. Also, please note the following:
  - a) Certified SBEs who are bidding as prime contractors MUST complete and submit the top portion of Form SBE-2 to guarantee the 20% SBE credit.
  - b) SBEs with multiple geographical locations shall enter the Cuyahoga County address and contact information on Form SBE-2.
  - c) Prime vendors are **PROHIBITED** from using SBE(s) with whom the prime vendor has a familial relationship, joint or co-ownership, common partners, officers, or a shareholder relationship to meet the SBE Participation Goal. Hence, on Cuyahoga County projects/contracts, any portion of work subcontracted to a SBE vendor by a prime vendor that meets the above-mentioned criteria will **NOT** count towards the achievement of the established SBE Participation Goal.

**Use of 2<sup>nd</sup> Tier Subcontractors**: In the event that a subcontractor portions out work and utilizes the services of a sub-subcontractor or vendor, **the prime contractor** shall be required to report this use to DEI. For reporting purposes, the prime contractor shall report statistical data for the sub-subcontractor or sub-vendor, including race, gender, business size, area of specialization, dollar value, description of services or products purchased, and contact information. No SBE subcontractor will be permitted to subcontract more than 25% of their subcontract work (based on dollar value) without prior approval by DEI.

**Other Information and Data**: DEI may request additional information and data prior to a contract award. This information may include, but is not limited to, information regarding business ownership of all subcontractors to be utilized on the project, all of which shall reflect the race, gender, location, size, and area of specialization and structure of the identified businesses.

---

**A PARTICIPANT'S FAILURE OR REFUSAL TO PROVIDE INFORMATION AND DATA REQUIRED BY THIS PROGRAM AND REQUESTED BY DEI SHALL SUBJECT THE PARTICIPANT TO HAVING A PROPOSAL OR BID DEEMED NON-RESPONSIVE.**

---



## **V. Good Faith Efforts**

Aggressive “Good Faith Efforts” to include SBEs in the procurement process are required of all Participants. These Good Faith Efforts should be in addition to the Participant’s regular and customary solicitation process of contact with potential subcontractors and/or vendors.

Written Notice to SBEs: To demonstrate good faith efforts, a Participant shall deliver written or electronic notice to potential SBEs. SBEs should be contacted not less than one (1) week before the bid or proposal due date. Names, addresses, and telephone numbers for available SBEs may be obtained by contacting DEI or reviewing the database on the website at <https://opd.cuyahogacounty.us/en-US/listing.aspx> .

The written or electronic notice sent to potential subcontractors or vendors shall contain the following:

- (1) Sufficient information about the plans, specifications, and relevant terms and conditions of the solicitation. This should include information about the work which will be subcontracted or the goods which will be obtained from subcontractors and suppliers;
- (2) A contact person knowledgeable of the project scope documents, within the Participant’s office, to answer questions about the conditions of the contract;
- (3) Information as to the Participant’s bonding requirements; and
- (4) The deadline for price quotations.

Evaluation of Good Faith Efforts: In evaluating good faith efforts, DEI will determine whether the Participant has made reasonable good faith efforts to obtain SBE participation as part of its bid or proposal. DEI may evaluate not only the different kinds of efforts made by a Participant, but also the quantity and intensity of those efforts.

DEI will consider a completed Good Faith Effort Certification (SBE-3, 2 pages, found in the attached Bidder’s Manual), as evidence of a Participant’s good faith in trying to obtain SBE participation in a bid or proposal.

Required Documentation: To demonstrate good faith efforts, Participants shall keep detailed records of all correspondences and responses thereto, emails, logs of all telephone calls made and received regarding the project or contract, confirmation receipts for fax transmissions, receipts from registered or certified mail, copies of advertisements in publications and other media, and other relevant papers required by this Program.

Good Faith Effort Certification: Participant must submit a completed Good Faith Certification (SBE-3, found in the Bidder’s Manual) ONLY if the SBE Participation Goal is not met. Additional documentation demonstrating a good faith effort must accompany the checklist (as detailed above in *Required Documentation*). The completed document must contain an original signature, notarizations, and date of signature.

Administrative Reconsideration: If DEI determines that the apparent successful vendor is non-compliant on meeting the SBE participation goal and has not demonstrated good faith efforts to obtain SBE participation, prior to awarding the contract/purchase, the user department shall notify the apparent successful vendor of the determination of non-compliance by emailing the primary contact detailed in the vendor's bid/proposal. The apparent successful vendor shall have the right to request an administrative reconsideration of the non-compliance determination. The administrative reconsideration can be a "no meeting" reconsideration or "meeting" reconsideration (virtual or in-person). The request for an administrative reconsideration must be submitted within three (3) business days of the notification of non-compliance and in the format of an email to DEI at [dei@cuyahogacounty.us](mailto:dei@cuyahogacounty.us). Upon receipt of the request for the administrative reconsideration by the apparent successful vendor, DEI shall forward the request to the Administrative Reconsideration Panel. The panel shall consist of at least three (3) but not more than five (5) County employees appointed by the Cuyahoga County Executive. The request for administrative reconsideration shall detail the pertinent RFB/RFP/RFQ (i.e., title, description...), type of administrative reconsideration requested (i.e., no meeting or meeting), and any written documentation or arguments concerning the issue of non-compliance. DEI shall provide a summary of its Good Faith Effort evaluation and supporting documentation. The Administrative Reconsideration Panel shall publish a schedule that includes deadlines and provides for a frequency of no less than twice per calendar month. The Administrative Reconsideration Panel will evaluate the information provided by the apparent successful vendor and DEI and issue a written decision approving or disapproving of DEI's determination on non-compliance for the matter. A quorum for "no meeting" or "meeting" administrative reconsideration shall be the majority (i.e., greater than 50%) of the appointed panel and an affirmative vote by the majority (i.e., greater than 50%) of the panel present for the administrative reconsideration is required for action. The Administrative Reconsideration Panel shall adopt its own rules of procedure consistent with SBE Policies and Procedures. The result of the administrative reconsideration is not administratively appealable.

## **VI. Award of Contracts**

Award of Contract: Proposals/bids may be rejected and projects re-submitted for the sole purpose of attaining goals where no "good faith effort" has been demonstrated. Cuyahoga County reserves the right to determine the action to be taken on the contract if a goal is not met, including rejecting any or all bids or proposals. For RFPs and RFQs, once the scope of work and/or price, terms, and conditions have been finalized but in advance of submission for approval by the pertinent contracting authority, the department shall confirm with DEI that the proposed contract/purchase is compliant with the SBE participation goals and/or Good Faith Efforts requirements. If an awarded contract is later amended for additional dollars, SBE subcontractor participation should still reflect the percentage of dollars originally contracted for.

When evaluating a bid to determine the lowest and best bid, the County may consider, in addition to all of the other factors set forth in the instructions to bidders, whether a bid is compliant with the applicable SBE goals, provided, however, that such compliance shall not be considered if the difference between the SBE-compliant bid and the lowest responsive bid is more than the price preference specified below.

Lowest Bid Received Range (\$)	Price Preference (%) & Limit	Price Preference (\$)
0 – 500,000	10%	0 – 50,000
500,000.01 – 1,000,000	10% up to max \$80,000 (10-8)	50,000.01 – 80,000
1,000,000.01 – 3,000,000	8% up to max \$210,000 (8-7)	80,000.01 – 210,000
3,000,000.01 – 5,000,000	7% up to max \$250,000 (7-5)	210,000.01 – 250,000
>5,000,000	\$250,000 maximum ( $\leq 5$ )	250,000 maximum

## **VII. Monitoring and Post-Award Reporting**

Department of Equity and Inclusion Authorization to Monitor: DEI shall be authorized to collect from all Participants such data and information as is necessary to monitor this Program. This information may include information as to business ownership, supplier information, subcontractor information, all of which shall reflect the contract information, race, gender, business location, and size of the identified businesses.

DEI shall monitor the participation of SBEs in the procurement of goods and services for Cuyahoga County. Such monitoring shall include, but is not necessarily limited to, a statistical analysis of each construction trade, business service, professional service, and commodity to determine whether there is utilization of SBEs in a manner that is proportionate to the established goal.

DEI will provide written reports on an annual basis. DEI's report shall contain a summary of the purchases and contracts placed with SBEs for the period and the relative percentage to the total of purchases and contracts for that period.

Participant's Post-Award Reporting: Participants who are awarded contracts must submit reports on a monthly basis during the course of, at the end of the contract, and as requested by DEI. Participants shall comply with all reporting requirements related to SBE utilization including, but not limited to, completing on-line reporting of payments made to SBE subcontractors and other subcontractors. These reports shall summarize the number and dollar amounts of payments made during the term of the contract to subcontractors. At the end of the contract, the final report shall summarize the number and dollar amounts of payments made during the term of the contract to all subcontractors and shall reflect the SBEs designation of the subcontractor if any. DEI reserves the right to audit a contract for SBE participation at its discretion during any phase of the project. An audit would include but not be limited to: on site reviews, desk reviews, requests for cancelled checks, requests for invoices, certified payroll reports, etc. Participants shall contact DEI if concerns arise related to its ability to meet the SBE goals and to seek guidance on available options to meet the goals.

SBE Subcontractor Substitutions or Replacements: The prime contractor shall report any replacements or substitutions of the use of SBE subcontractors to DEI immediately. Prior approval by the Director of DEI is required for SBE substitutions/replacements. For reporting purposes, the prime contractor shall report to DEI statistical data pertaining to the new subcontractor, including race, gender, business size, area of specialization, and contact information on the SBE Subcontractor Participation Plan form (SBE-2).

DEI will require a Participant to make good faith efforts to replace a SBE that is terminated or has otherwise failed to complete its work on a contract with another SBE to the extent needed to meet the contract SBE Participation Goal. The Participant must notify DEI immediately, and in writing, of the SBE's inability or unwillingness to perform and provide reasonable documentation. The request should include at a minimum: the name of the SBE firm, the contact, the phone number, the scope of work initially assigned to the SBE firm,

dollars paid to date, percent of scope completed, and the reason for the substitution request including documentation of the SBE's withdrawal.

The Participant will be given five (5) business days to find a SBE substitution if the request is granted. In this situation, the Participant will be required to obtain prior approval of the substitute SBE and to provide copies of SBE Subcontractor Participation Plan (SBE-2) or documentation of good faith efforts.

If the Participant fails or refuses to comply in the time specified, DEI may issue a recommendation to stop all or part of payment and/or work until satisfactory action has been taken. If the Participant still fails to comply, DEI may issue a recommendation of termination of the contract.

Contractors' Closeout Activity Reports: To further monitor SBE participation, closeout activity reports will be required from project prime contractors and prime consultants identifying activities of **all** subcontractors and sub-consultants (i.e., non-SBEs and SBEs). For all subcontractors and sub-consultants used, the prime contractor shall provide the following information: contact information, ethnicity/race/gender of ownership, summary of scope of work provided, and total payments for said scope of work. This report shall include all modifications/amendments/change orders. The prime contractors/consultants shall provide justification and documentation for SBE participation shortfalls.

DRAFT

## **REQUIRED DOCUMENTS**

The following forms regarding the SBE Program must be completed and submitted with bids/proposals:

- COVENANT OF NON-DISCRIMINATION (SBE-1)
- SBE SUBCONTRACTOR PARTICIPATION PLAN (SBE-2)
- GOOD FAITH EFFORT CERTIFICATION (SBE-3, 2 PAGES)

DRAFT

COVENANT OF NON-DISCRIMINATION

(MUST be completed and submitted with ALL bids or proposals)

Know All Men By These Presents, that I/we, ( \_\_\_\_\_ ),  
Name(s)  
( \_\_\_\_\_ ), ( \_\_\_\_\_ ),  
Title(s) Name of Company

(hereinafter "Company"), in consideration of the privilege to submit Bids/Proposals on contracts funded, in whole or in part, by Cuyahoga County, hereby consents, covenants, and agrees as follows:

(1) No person shall be excluded from participation in, denied the benefit of, or otherwise discriminated against on the basis of race, creed, color, national origin, handicap, sex, age, marital status, or sexual orientation in connection with any Bid/Proposal submitted to Cuyahoga County or the performance of any contract resulting from;

(2) That it is and shall be the policy of this Company to provide equal opportunity to all business persons seeking to contact or otherwise interested in contracting with this Company, including various eligible Small Business Enterprises (hereinafter "SBEs");

(3) In connection herewith, I/We acknowledge and warrant that this Company has been made aware of, understands, and agrees to make a Good Faith Effort to solicit SBEs to do business with this Company;

(4) That the Covenant of Non-Discrimination as made and set forth herein shall be continuing in nature and shall remain in full force and effect without interruption;

(5) That the Covenant of Non-Discrimination as made and set forth herein shall be and are hereby deemed to be made a part of, and incorporated by reference into, any contract or portion thereof which this Company may hereafter obtain; and

(6) That the failure of this Company to satisfactorily discharge any of the Covenant of Non-Discrimination as made and set forth herein shall constitute a material breach of contract entitling Cuyahoga County to declare the contract in default and to exercise any and all applicable rights and remedies, including but not limited to, cancellation of the contract, termination of the contract, suspension and debarment from future contracting opportunities, and withholding and/or forfeiture of compensation due and owing on a contract.

\_\_\_\_\_  
(Original Signature of Company Representative Identified Above)

\_\_\_\_\_  
(Date)

**SBE SUBCONTRACTOR PARTICIPATION PLAN**  
**(MUST be submitted for EACH SBE Subcontractor Proposed)**

(A) TOTAL AMOUNT OF OVERALL CONTRACT BID/PROPOSAL \$ \_\_\_\_\_

BUSINESS NAME OF PRIME BIDDER \_\_\_\_\_

ADDRESS \_\_\_\_\_

CITY \_\_\_\_\_ STATE \_\_\_\_\_ ZIP CODE \_\_\_\_\_

TELEPHONE (\_\_\_\_) \_\_\_\_\_ E-MAIL \_\_\_\_\_

PRIME FIRM OWNED BY: NON-MBE/WBE/SBE  SBE SMALL BUSINESS ENTERPRISE   
MBE MINORITY BUSINESS ENTERPRISE  WBE WOMEN BUSINESS ENTERPRISE

(B) AMOUNT TO BE SUBCONTRACTED TO SBE (PLEASE CIRCLE ONE): \$ \_\_\_\_\_ PERCENT OF TOTAL OVERALL CONTRACT BID [(B)/(A)]: \_\_\_\_\_ %

SCOPE OF WORK PROVIDED BY SBE: \_\_\_\_\_

PRIME BIDDER'S NAME \_\_\_\_\_ TITLE \_\_\_\_\_  
(TYPE OR PRINT)

PRIME BIDDER'S SIGNATURE \_\_\_\_\_  
(DATE OF SIGNATURE)

**SBE SUBCONTRACTOR TO BE UTILIZED**  
(MUST BE CERTIFIED BY THE CUYAHOGA COUNTY DEPARTMENT OF EQUITY AND INCLUSION)

NAME OF SUBCONTRACTOR \_\_\_\_\_

ADDRESS \_\_\_\_\_

CITY \_\_\_\_\_ STATE \_\_\_\_\_ ZIP CODE \_\_\_\_\_

TELEPHONE AREA CODE ( ) \_\_\_\_\_  
 SMALL BUSINESS SBE  MINORITY BUSINESS MBE  WOMEN BUSINESS WBE

**\*\*\*\*\*NOTE: MUST BE A COUNTY CERTIFIED SBE \*\*\*\*\***

THE UNDERSIGNED HEREWITH AGREES TO SUBCONTRACT WITH THE ABOVE NAMED BIDDER FOR THE ABOVE SAID SERVICE(S) OR SUPPLY(IES) TO BE FURNISHED TO THE COUNTY.

SUBCONTRACTOR'S NAME \_\_\_\_\_ TITLE \_\_\_\_\_  
(TYPE OR PRINT)

SUBCONTRACTOR'S SIGNATURE \_\_\_\_\_  
(DATE OF SIGNATURE)

### GOOD FAITH EFFORT CERTIFICATION

(Must be submitted with bids/proposals NOT meeting the SBE goal or requesting full or partial waiver)

Pursuant to the requirements for bidders under the SBE Program, and in consideration of the privilege to submit bids/proposals funded, in whole or in part, by Cuyahoga County,

I/We, ( \_\_\_\_\_ ), ( \_\_\_\_\_ ) of ( \_\_\_\_\_ )  
Name(s) of Person(s) Signing Below Title(s) Company Name

attest that I/We have exercised the following good faith efforts in addition to my/our regular and customary solicitation process: (Check ALL that apply and complete as indicated)

- I/We are requesting a FULL/PARTIAL WAIVER of the SBE Participation Goal for the following reason(s): \_\_\_\_\_  
\_\_\_\_\_
- I/We are a non-profit agency and are requesting a FULL WAIVER of the SBE Goal. **(MUST SUBMIT/ATTACH PROOF)**
- I/We have contacted DEI or website to obtain a list of SBEs appropriate to the bid/proposal.
- I/We delivered written notice to available certified SBEs for each potential subcontracting or supply category in the contract AND all potential subcontractors or vendors which requested information on the contract. **(MUST SUBMIT/ATTACH PROOF)**
- I/We have provided all potential subcontractors or vendors with adequate information as to plans, specifications, relevant terms and conditions of the contract, bonding requirements, and the last date and time for receipt of price quotations. **(MUST SUBMIT/ATTACH PROOF)**
- I/We have attended the pre-bid/proposal conference.
- I/We have **provided a written explanation for rejection of any potential** SBE subcontractor or vendor to DEI. When the SBE subcontractor rejection is due to unreasonably high pricing, I/We have provided supporting documentation.
- I/We have actively solicited, through sending letters, emails or initiating personal contact, SBEs in all feasible and appropriate categories providing subcontracting opportunities for the contract under consideration. **(MUST SUBMIT/ATTACH PROOF)**
- I/We have utilized the services of available community organizations and associations, contractors' groups, and trade associations known to publicize contracting and procurement opportunities, for the purpose of obtaining assistance in the contacting and recruitment of SBEs for the Cuyahoga County contract under consideration. **(MUST SUBMIT/ATTACH PROOF)**
- I/We have conducted discussions with interested SBEs in good faith and provided the same willingness to assist SBEs as has been extended to any other similarly situated subcontractor.
- I/We have taken steps to ensure that all labor supervisors, superintendents, and other on-site supervisory personnel are aware of and carry out the obligation to maintain a non-discriminatory work environment, free of harassment, intimidation and coercion at all construction sites, offices and other facilities to which employees are assigned to work.





DRAFT

\*\*\*\* SAMPLE FORMS \*\*\*\*

COVENANT OF NON-DISCRIMINATION

(MUST be completed and submitted with ALL bids or proposals)

Know All Men By These Presents, that I/we, ( John Doe ),  
Name(s)  
( President, Owner ), ( ABC Company, Inc. ),  
Title(s) Name of Company

(hereinafter "Company"), in consideration of the privilege to submit Bids/Proposals on contracts funded, in whole or in part, by Cuyahoga County, hereby consents, covenants, and agrees as follows:

(1) No person shall be excluded from participation in, denied the benefit of, or otherwise discriminated against on the basis of race, creed, color, national origin, handicap, sex, age, marital status, or sexual orientation in connection with any Bid/Proposal submitted to Cuyahoga County or the performance of any contract resulting from;

(2) That it is and shall be the policy of this Company to provide equal opportunity to all business persons seeking to contact or otherwise interested in contracting with this Company, including various eligible Small Business Enterprise (hereinafter "SBEs");

(3) In connection herewith, I/We acknowledge and warrant that this Company has been made aware of, understands, and agrees to make a Good Faith Effort to solicit SBEs to do business with this Company;

(4) That the Covenant of Non-Discrimination as made and set forth herein shall be continuing in nature and shall remain in full force and effect without interruption;

(5) That the Covenant of Non-Discrimination as made and set forth herein shall be and are hereby deemed to be made a part of, and incorporated by reference into, any contract or portion thereof which this Company may hereafter obtain; and

(6) That the failure of this Company to satisfactorily discharge any of the Covenant of Non-Discrimination as made and set forth herein shall constitute a material breach of contract entitling Cuyahoga County to declare the contract in default and to exercise any and all applicable rights and remedies, including but not limited to, cancellation of the contract, termination of the contract, suspension and debarment from future contracting opportunities, and withholding and/or forfeiture of compensation due and owing on a contract.

John Doe  
(Original Signature of Company Representative Identified Above)

February 1, 2021  
(Date)

**SBE SUBCONTRACTOR PARTICIPATION PLAN**  
**(MUST be submitted for EACH SBE Subcontractor Proposed)**

(A) TOTAL AMOUNT OF OVERALL CONTRACT BID/PROPOSAL \$ 500,000.00

BUSINESS NAME OF PRIME BIDDER ABC COMPANY, INC

ADDRESS 111 MAIN STREET

CITY ANYWHERE STATE OHIO ZIP CODE 44000

TELEPHONE ( 216 ) 555-5555 E-MAIL ABCCOMPANY@YAHOO.COM

PRIME FIRM OWNED BY: NON-MBE/WBE/SBE  SBE SMALL BUSINESS ENTERPRISE   
MBE MINORITY BUSINESS ENTERPRISE  WBE WOMEN BUSINESS ENTERPRISE

(B) AMOUNT TO BE SUBCONTRACTED TO SBE (PLEASE CIRCLE ONE): \$ 50,000.00 PERCENT OF TOTAL OVERALL CONTRACT BID [(B)/(A)]: 10 %

SCOPE OF WORK PROVIDED BY SBE: ELECTRICAL CONTRACTING SERVICES

PRIME BIDDER'S NAME JOHN DOE TITLE PRESIDENT/OWNER  
(TYPE OR PRINT)

PRIME BIDDER'S SIGNATURE JOHN DOE FEBRUARY 1, 2021  
(DATE OF SIGNATURE)

**SBE SUBCONTRACTOR TO BE UTILIZED**  
(MUST BE CERTIFIED BY THE CUYAHOGA COUNTY DEPARTMENT OF EQUITY AND INCLUSION)

NAME OF SUBCONTRACTOR ELECTRIFYING ELECTRIC COMPANY

ADDRESS 456 MAIN STREET

CITY ANYWHERE STATE OHIO ZIP CODE 44000

TELEPHONE AREA CODE ( 216 ) 555-5551  SMALL BUSINESS SBE  MINORITY BUSINESS MBE  WOMEN BUSINESS WBE

\*\*\*\*\*NOTE MUST BE A COUNTY CERTIFIED SBE\*\*\*\*\*

THE UNDERSIGNED HERewith AGREES TO SUBCONTRACT WITH THE ABOVE NAMED BIDDER FOR THE ABOVE SAID SERVICE(S) OR SUPPLY(IES) TO BE FURNISHED TO THE COUNTY.

SUBCONTRACTOR'S NAME TOM EDISON TITLE PRESIDENT/OWNER  
(TYPE OR PRINT)

SUBCONTRACTOR'S SIGNATURE TOM EDISON FEBRUARY 1, 2021  
(DATE OF SIGNATURE)

### GOOD FAITH EFFORT CERTIFICATION

(Must be submitted with bids NOT meeting Diversity goal or requesting full or partial waiver)

Pursuant to the requirements for bidders under the SBE Program, and in consideration of the privilege to submit bids/proposals funded, in whole or in part, by Cuyahoga County,

I/We, ( John Doe ), ( President, Owner ) of ( ABC Company, Inc. )  
Name(s) of Person(s) Signing Below Title(s) Company Name

attest that I/We have exercised the following good faith efforts in addition to my/our regular and customary solicitation process: (Check ALL that apply and complete as indicated)

- x I/We are requesting a FULL/PARTIAL WAIVER of the SBE Participation Goal for the following reason(s): We are requesting a partial waiver of the SBE Goal as we were only able to meet 10% of the 15% goal. We were unable to find a SBE to meet the additional 5% required.
- I/We are a non-profit agency and are requesting a FULL WAIVER of the SBE Participation Goal. **(MUST SUBMIT/ATTACH PROOF)**
- x I/We have contacted DEI or website to obtain a list of the Diversity listing to appropriate to the bid/proposal.
- x I/We delivered written notice to available certified SBEs for each potential subcontracting or supply category in the contract AND all potential subcontractors or vendors which requested information on the contract. **(MUST SUBMIT/ATTACH PROOF)**
- x I/We have provided all potential subcontractors or vendors with adequate information as to plans, specifications, relevant terms and conditions of the contract, bonding requirements, and the last date and time for receipt of price quotations. **(MUST SUBMIT/ATTACH PROOF)**
- x I/We have attended the pre-bid/proposal conference.
- x I/We have **provided a written explanation for rejection of any potential** SBE subcontractor or vendor to DEI. When the SBE subcontractor rejection is due to unreasonably high pricing, I/We have provided supporting documentation.
- x I/We have actively solicited, through sending letters, emails or initiating personal contact, SBEs in all feasible and appropriate categories providing subcontracting opportunities for the contract under consideration. **(MUST SUBMIT/ATTACH PROOF)**
- x I/We have utilized the services of available community organizations and associations, contractors' groups, and trade associations known to publicize contracting and procurement opportunities, for the purpose of obtaining assistance in the contacting and recruitment of SBEs for the Cuyahoga County contract under consideration. **(MUST SUBMIT/ATTACH PROOF)**
- x I/We have conducted discussions with interested SBEs in good faith and provided the same willingness to assist SBEs as has been extended to any other similarly situated subcontractor.
- x I/We have taken steps to ensure that all labor supervisors, superintendents, and other on-site supervisory personnel are aware of and carry out the obligation to maintain a non-discriminatory work environment, free of harassment, intimidation and coercion at all construction sites, offices and other facilities to which employees are assigned to work.

If applicable, identify all SBEs contacted to participate that declined or were not chosen:

1. Perfect Plumbing Company 222 Main Street, Anywhere, OH 44000 216-555-5553  
Name of Subcontractor/Vendor Address Phone  
Paul Perfect January 15, 2021 \$25,000 (5%) January 18, 2021  
Name of Contact Date of Offer to Participate Bid Amount Date Offer Declined

Reasons Given for Declining Has other commitments at this time and is unable to work with us.

2. Dan's DuctWork Company 333 Main Street, Anywhere, OH 44000 216-555-5554  
Name of Subcontractor/Vendor Address Phone  
Dan Handy January 18, 2021 \$25,000 (5%) January 19, 2021  
Name of Contact Date of Offer to Participate Bid Amount Date Offer Declined

Reasons Given for Declining They are no longer providing the required sub-contracting service as part of its business.

3. Dave's Landscapes Inc 444 Main Street, Anywhere, OH 44000 216-555-5556  
Name of Subcontractor/Vendor Address Phone  
Dave Curbappeal January 16, 2021 \$25,000 (5%) January 17, 2021  
Name of Contact Date of Offer to Participate Bid Amount Date Offer Declined

Reasons Given for Declining Has other commitments at this time and is unable to work with us.

(Make additional copies to extend list of SBE contacts if needed)

I/We affix my/our signature to this document to attest that I/We have exercised the above-indicated Good Faith Efforts to promote Diversity participation on the Bid/Proposal and Contract under consideration and to comply fully with the provisions of the Cuyahoga County SBE Program.

John Doe  
Printed/Typed Name of Company Official

February 1, 2021  
Date

John Doe  
Signature (Must be Original)

President, Owner  
Title of Company Official

ABC Company, Inc.  
Full Company Name

111 Main Street  
Mailing Address

216-555-5555  
Area Code/ Phone Number

Anywhere, OH 44000  
City, State, Zip

Nancy Notarious  
Notary Public

December 31, 2023  
My Commission Expires

PLEASE NOTE: Failure to properly complete and submit **SBE-1, SBE-2, and SBE-3 (if applicable)** will result in bids/proposals being **ruled non-responsive**.

Exhibit B



COUNTY OF CUYAHOGA, OHIO

MINORITY BUSINESS ENTERPRISE (MBE)  
& WOMEN BUSINESS ENTERPRISE (WBE)  
PROGRAM  
POLICIES AND PROCEDURES

July 2021



# TABLE OF CONTENTS

I.	POLICY STATEMENT	2
II.	PROGRAM SCOPE AND APPLICABILITY	2
III.	THE DEPARTMENT OF EQUITY AND INCLUSION	3
IV.	CERTIFICATION	4
V.	ELIGIBILITY STANDARDS FOR MBE/WBE CERTIFICATION	4
VI.	OPERATIONAL CONTROL	6
VII.	MANAGERIAL CONTROL	6
VIII.	THE PURPOSE AND USE OF GOALS	7
IX.	WAIVERS AND WAIVER OF NON-COMPLIANCE WITH SBE GOAL	8
X.	REQUIREMENTS OF PRIME CONTRACTORS	9
XI.	GOOD FAITH EFFORTS	10
XII.	AWARD OF CONTRACTS	11
XIII.	MONITORING AND POST-AWARD REPORTING	12
XIV.	GRIEVANCE PROCESS	13
XV.	SANCTIONS AND PENALTIES FOR NON-COMPLIANCE	14
XVI.	TRAINING AND OUTREACH STRATEGIES	15
XVII.	BOND WAIVER PROGRAM	18
XVIII.	SEVERABILITY	18
XIX.	DEFINITIONS	18

APPENDIX A CUYAHOGA COUNTY MBE/WBE BIDDER'S MANUAL

## I. POLICY STATEMENT

Policy Statement: It is the policy of Cuyahoga County to ensure that all businesses have the opportunity to participate fully and fairly in Cuyahoga County's procurement and contract awards.

In an effort to ameliorate the effects of past and present arbitrary barriers that minority- and women-owned businesses have in contracting with Cuyahoga County, Cuyahoga County hereby adopts this Minority Business Enterprise (MBE) and Women Business Enterprise (WBE) program to:

- promote and encourage full and open competition in the procurement of goods and services by Cuyahoga County;
- encourage all Cuyahoga County personnel involved with procurement and contracting activities to maintain good faith efforts and appropriate purchasing procedures; and
- protect Cuyahoga County from becoming a passive participant in any unlawful discrimination; and to otherwise spur economic development in the public and private sectors of the Cuyahoga County economy.

Moreover, no person shall be denied the benefit of, or otherwise discriminated against, on the basis of race, creed, color, national origin, handicap, sex, age, marital status, or sexual orientation in connection with the award or modification of a contract between a vendor or contractor and Cuyahoga County where said contract is paid for, in whole or in part, with monetary appropriations by Cuyahoga County.

## II. PROGRAM SCOPE AND APPLICABILITY

The following categories provide an overview and summary of the nature and types of Cuyahoga County purchasing and contracting:

Category A – Construction, Architectural and Engineering: Includes any and all contracting relating to horizontal and vertical construction including architectural engineering, new construction, rehabilitation, remodeling, and repairs.

Category B - Commodities: Includes the purchase of all goods, equipment, food, office and other supplies, art, furniture, textbooks and other materials for education, and other tangible personal property not associated with the services identified in Categories A, B or C.

Category C - Professional Services: Includes the purchase of any or all services for which applicable selection criteria may require a Participant to possess a license or other certificate of competency such as accounting, auditing, landscape architecture, engineering, insurance, laboratory, legal, lifeguard, medical, dental, nursing, and student transportation.

Category D – Business Services: Includes the procurement of advertising, printing, non-construction repairs, janitorial services, training seminars and workshops, computer and information systems, security, shipping and mailing, microfiche and microfilm, courier, storage, travel, consulting, retail, and other non-professional services.

### III. THE DEPARTMENT OF EQUITY AND INCLUSION

The Department of Equity and Inclusion (DEI) develops, administers, and enforces the MBE/WBE Program. DEI shall encourage equal business opportunities and achieve the policies and objectives of the MBE/WBE Program by:

- (1) Administering and enforcing Cuyahoga County policies;
- (20) Establishing written rules, regulations, and procedures consistent with the MBE/WBE Program;
- (21) Publishing and making public said rules, regulations, and procedures;
- (22) Maintaining outreach and assistance programs to promote equal contracting opportunities for MBE/WBE businesses that wish to contract with the Cuyahoga County and educating vendors and contractors on the MBE/WBE Program, MBE/WBE Goals, and Good Faith Efforts Criteria;
- (23) Establishing, enhancing, and maintaining relationships with agencies and stakeholders in the area;
- (24) Maintaining a current database of available MBE/WBEs and making this database accessible to interested parties;
- (25) Monitoring and collecting data and information on the utilization of MBE/WBEs in Cuyahoga County's procurement activities that allows a comprehensive review of the impact of the MBE/WBE Program;
- (26) Establishing and assessing the reasonableness of MBE/WBE participation goals for Cuyahoga County procurements;
- (27) Attending pre-bid/proposal conferences for all procurement solicitations by Cuyahoga County;
- (28) Attending kick-off meetings for major projects;
- (29) Participating on evaluation panels for request for proposals and requests for qualifications;
- (30) Investigating written complaints related to the MBE/WBE Program;
- (31) Mediating payment disputes between prime contractors and MBE/WBE sub-contractors
- (32) Notifying affected parties in writing as to the right to review and appeal an adverse decision by DEI;
- (33) Monitoring Cuyahoga County's purchasing activities and determining compliance with MBE/WBE program policies and procedures;
- (34) Preparing annual reports on the MBE/WBE Program;
- (35) Reviewing and determining whether a contractor or vendor has failed to implement its contractual agreements and commitments regarding this policy;
- (36) Developing and revising MBE/WBE Program policies and procedures to implement current best practices and maintaining records of MBE/WBE Program activities; and
- (37) Performing other tasks as may be required to fulfill the above-stated duties of DEI.

Authority to Investigate Discriminatory Practices: A Participant's written complaint of discrimination shall be forwarded to the Commission on Human Rights for investigation and determination under Title XV of the County Code. Further, such investigations may be initiated by referral to the Commission on Human Rights when DEI receives information, which provides a reasonable basis to believe that an individual contractor

seeking to contract or contracting with Cuyahoga County may be engaging in public or private discriminatory conduct.

## IV. CERTIFICATION

**Certification:** Certification is the process that ensures that a particular business may become a part of a pool of vendors identified for the purpose of increasing opportunities with respect to contracts and purchases awarded by Cuyahoga County.

All firms submitting applications for MBE/WBE consideration must be certified prior to submission of a bid or proposal.

Applications for certification will be on standard forms provided by the Cuyahoga County and will include, but will not be limited to, primary business location, evidence of ownership, control, operation, and experience. The application shall be in the form of an affidavit and shall be signed by the applicant; such signature to be notarized by an officer duly authorized to notarize signatures. All certified MBE/WBE firms will be required to update their listing continually including changes of addresses, telephone numbers and changes of ownership, control, and operation. In addition to the applications for certification, vendors seeking MBE/WBE certification shall also submit documentation demonstrating eligibility for certification, managerial control, and operational control. This documentation includes, but is not limited to, federal business tax returns, federal personal tax returns, proof of capital investment or contribution, corporate documents (i.e., Articles of Incorporation, Share Ledger, Corporate Bylaws...), bank signature card, current lease/rental agreement or property taxes for business location, business licenses, worker's compensation certificate and proof of identification for all who own 5% or more of the business.

The Director of DEI shall grant certification of an approved MBE/WBE Business for a period of two (2) years. The Director may grant a provisional certification prior to specific bids or proposals. All companies must recertify their business depending on the expiration date of their certificate which in most instances is the anniversary of their certification. Should provisional certification be granted to a business and that business be awarded a prime contract and the provisional certification is later rescinded, that business is obligated to meet the MBE/WBE participation percentage goal of the original proposal or specifications. Cuyahoga County has a reciprocal certification agreement with the State of Ohio, Department of Administrative Services, on behalf of its Equal Opportunity Division for the Minority Business Enterprise Program.

If a business is denied certification on the basis of information submitted, the company cannot reapply for certification for a period of one (1) year from the date of the notice or denial, provided that such company shall have the right to appeal such denial and to be certified if such appeal is decided in its favor as provided herein. Certification records will be maintained by DEI for a period of five (5) years.

## V. ELIGIBILITY STANDARDS FOR CERTIFICATION

The following standards will be used to determine whether a firm is eligible to be certified as a Minority Enterprise Business and/or Women Business Enterprise:

2. To become eligible for the MBE/WBE Program, a business firm must demonstrate that it has been in continuous operation in the category or the related category for which it is requesting certification for one year and that majority ownership has at least one (1) year of work experience relevant to the business' certification category. A business applying for MBE certification must establish that it is an

individual, domestic corporation, sole proprietorship, partnership, joint venture, entity, or company that is at least 51% owned by one or more individuals who are African American, Hispanic American, Native American, Asian-Pacific American, or Asian-Indian American. A business applying for WBE certification must establish that it is an individual, domestic corporation, sole proprietorship, partnership, joint venture, entity, or company that is at least 51% owned by one or more women.

9. A business applying for MBE/WBE certification must establish that it has a physical presence located within the geographical limits of Cuyahoga County, Geauga County, Lake County, Lorain County, and Medina County. Mailbox facilities or other similar arrangements alone do not constitute a physical presence.
10. MBE/WBE ownership and control shall be real, substantial, and continuing and shall go beyond the “pro forma” ownership as reflected in the ownership document. The MBE/WBE owners shall share in the risks and profits commensurate with their ownership interest as demonstrated by an examination of the substance rather than form of arrangements.
11. MBE/WBE owners shall possess the power to direct or cause the direction of the management and policies of the firm and to make the day-to-day as well as major decisions on matters of management, policy, and operation. The firm shall not be subject to any formal or informal restrictions that limit the customary discretion of the MBE/WBE owners. There shall be no restrictions through, for example, by-law provisions, partnerships, arrangements, or charter requirements for cumulative voting rights or otherwise that prevent the business owners, without the cooperating or vote of any owner who is not listed, from making a business decision of the firm.
12. Where the actual management of the firm is contracted out to individuals other than the owner, those persons who have the ultimate power to hire and fire managers can, for the purpose of this part, be deemed to be controlling the business.
13. All securities that constitute ownership and/or control of a corporation shall be held directly by the owners. No securities held in trust, or by any guardian for a minor, shall be considered as held by an owner in determining the ownership or control of a corporation. If a business denied certification due to securities held in trust appeals to and is granted a waiver of this eligibility requirement by the Grievance Hearing Board, then the waiver granted by the Grievance Hearing Board shall remain in effect for that business provided that the ownership structure remains unchanged.
14. The contribution of capital or expertise by the owners to acquire their interest in the firm shall be real and substantial. Examples of insufficient contributions include a promise to contribute capital, a note payable to firm, or the mere participation as an employee, rather than as a manager.
15. In addition to the above standards, special consideration shall be given to the following circumstances in determining eligibility for certification:
  - a. Newly formed firms and firms whose ownership and/or control has changed since the date of the advertisement of the contract are closely scrutinized to determine the reasons for the timing of the formation of or change in the firm.
  - d. A previous and/or continuing employer-employee relationship between or among present owners is carefully reviewed to ensure that the employee-owner has management responsibilities and capabilities discussed in this section.
  - e. Any relationship between a MBE/WBE and any other business which is not a MBE/WBE business or belonging to a non-MBE/WBE business, which has an interest in the MBE/WBE business is carefully reviewed to determine if the interest of the non-

MBE/WBE business conflicts with the ownership and control requirements of this section.

## VI. OPERATIONAL CONTROL

DEI shall review the extent of “operational” control. The primary consideration in determining operational control and the extent to which the applicant actually operates the business will rest upon the peculiarities in the industry of which the business is a part. For example, for small contractors, it is reasonable to expect the applicant to be knowledgeable of all aspects of the business. This may not apply to large contractors who have the assets and personnel to specialize. Accordingly, in order to clarify the level of operational involvement, which an applicant must have in a business for it to be considered eligible, the following criteria are put forth, but are not intended to be all inclusive.

1. The applicant should have some experience in the industry for which certification is being sought.
4. The applicant should show that basic decisions pertaining to the daily operations of business can be independently made. This means the applicant must possess the knowledge to weigh all advice given and to make an independent determination.
5. The applicant should have some technical competence in the industry in which certification is being sought. Technical competence in this sense does not mean expert knowledge. It does mean the applicant should have a working knowledge of the technical requirements of the business needed to operate in the industry.

## VII. MANAGERIAL CONTROL

DEI shall review the extent of “managerial” control. Managerial control means that the applicant has the demonstrable ability to make independent and unilateral business decisions needed to guide the future of the business. Managerial control may be demonstrated in many ways. For an applicant to demonstrate managerial control, the following criteria are put forth, but are not intended to be all-inclusive:

1. Articles of incorporation, corporate bylaws and partnership agreements or other agreements shall be free of restrictive language, which would dilute the applicant’s control, thereby preventing the applicant from making those decisions, which affect the future of the business.
4. The applicant shall be able to show clearly through production of documents the areas of applicant control, such as, but not limited to:
  - e) Authority and responsibility to initiate and sign checks, letters of credit, and loan agreements.
  - f) Authority to negotiate and signature authority for insurance and/or bonds.
  - g) Authority to negotiate for banking services.
  - h) Authority to hire and fire employees.
5. Agreements for support services that do not lessen the applicant’s control of the company are permitted as long as the applicant’s power to manage



the company is not restricted or impaired.

## VIII. THE PURPOSE AND USE OF GOALS

Definition and Purpose: Cuyahoga County maintains a compelling interest in providing equal business opportunities for all persons wishing to do business with it. Therefore, DEI will continue to encourage, monitor, and track MBE/WBE business participation in the procurement process through the MBE/WBE participation goals. Goals are not quotas, but rather a method enabling Cuyahoga County to encourage and promote inclusion of MBE/WBEs in the procurement process.

Procedure for Establishing Overall Goals: Cuyahoga County has established an overall subcontracting goal for MBE/WBE Participation in County procurements that will vary by work categories based on the latest Disparity Study.

Procedure for Establishing Individual Goals: For each procurement, the County department/agency shall provide the NIGP code and estimated cost for each scope of work within a procurement as part of the specification packet for each bid, RFP, and RFQ to DEI in advance of the desired solicitation/award initiation date to enable DEI ample time to determine the MBE/WBE participation goals for the procurement. To achieve the overall goal for MBE/WBE participation, the Director of DEI will establish MBE/WBE participation goals on a contract-by-contract basis by determining the available MBEs/WBEs using the latest Disparity Study data for each scope of work within a procurement and weighting that availability based on the percentage that scope represents within the procurement. Separate goals will be set for MBEs and WBEs. The Director of DEI may also waive the MBE/WBE goals for particular procurements as outlined in Section IX. (1).

Cuyahoga County will use the following criteria to determine the types of participation toward Cuyahoga County's overall annual MBE/WBE goals:

- 4) The total dollar value of the subcontract may be counted toward determining the specified goals. This includes the fees and commissions charged for professional services, legal counsel, manufacturers, financial consultants, and insurance agents.
- 5) Contract goals will be used to meet any portion of the annual goal. Contract goals are established so that, over the period to which the goal applies, they will cumulatively result in meeting any portion of the goal projected to be met through the use of the different programs.
- 6) Contract goals will only be established on those contracts that have subcontracting opportunities for MBE/WBE Participation. The size of contract goals will be adapted to the circumstances of each contract (e.g., type and location of work, availability of the MBE/WBEs to perform the particular type of work) and functionality within the contract.

MBE/WBE Participation in Meeting Goals: All Participants, including MBE/WBE Participants, shall make good faith efforts to attain goals through all subcontractor work.

- (1) Prime Contractors: A Prime Contractor should subcontract portions of its contract consistent with industry standards. However, all MBE/WBE subcontractors must perform a commercially useful function as defined herein. Only such participation by an MBE/WBE will be counted towards any goal.
- (2) Subcontractor Participation: Where a Prime utilizes one or more subcontractors or 2<sup>nd</sup> tier subcontractors to attain a MBE/WBE goal, the Participant may only count said MBE/WBE

subcontractor or sub-subcontractor work once toward goals. In no way shall subcontractors' or sub-subcontractors' work or dollar amount be construed to count toward said goal more than once. Only expenditures to MBE/WBE subcontractors that perform a commercially useful function in the work of that project or contract will be counted.

- (3) Supplier Participation: Where a Participant utilizes suppliers or distributors to satisfy the goal(s) in whole or in part, the MBE/WBE suppliers must perform a commercially useful function. Supplier participation may be approved upon review of the following factors:
- i) The nature and amount of supplies to be furnished;
  - ii) Whether the MBE/WBE is a manufacturer, wholesaler or distributor of the supplies and has the capabilities to deliver same in accordance with its certification;
  - iii) Whether the MBE/WBE actually performs, manages, and supervises the work to furnish the supplies; and
  - iv) Whether the MBE/WBE business intends to purchase supplies from a non-MBE/WBE and simply resell same to the general or prime contractor for allowing those supplies to be counted towards fulfillment of the goal(s). Participants will receive no credit for the dollar amount of the supply contracted from brokers.

## IX. WAIVERS AND WAIVER OF NON-COMPLIANCE WITH MBE/WBE GOAL

1. This MBE/WBE Program policy may be waived for the following:
  - h) "Sole Source" procurements under the Cuyahoga County ordinances which by their very nature limit the source of supply to one vendor.
  - i) County purchases from political subdivisions/government entities;
  - j) County purchases off state contracts, off federal contracts, and from joint purchasing programs;
  - k) The acquisition of any interest in real property including lease holdings;
  - l) Direct and indirect employee payments including payroll expenditures, pensions, and unemployment compensation and other employee-related expenditures;
  - m) Any other categories and subcategories of goods and services Cuyahoga County may from time to time establish as excluded contracts upon recommendation of the Director of the Department of Equity and Inclusion and approval by the Cuyahoga County Executive and Cuyahoga County Council;
  - n) Purchases and contracts being procured using Informal RFBs, RFPs, and RFQs (estimated total value \$1,000.01-\$49,999.99): As part of its solicitation process, the department shall also solicit bids/proposals from County certified MBEs/WBEs when available. To determine MBE/WBE availability, at least two (2) business days in advance of the posting/advertisement period, the department shall check the list of County certified MBEs/WBEs on the County's website (<https://opd.cuyahogacounty.us/en-US/listing.aspx>) and/or contact the Department of Equity and Inclusion for a list of pertinent County certified MBEs/WBEs. For these transactions, when the department solicits bids/proposal/qualifications through the vendor email notification system (currently the Infor Strategic Sourcing Module) in accordance with County Code Section 501.12 E, the department shall notify the pertinent available MBEs/WBEs using the vendor email notification system of the purchasing and contracting opportunity. Also, if required, as part of the additional solicitation efforts, the department shall also notify the pertinent available MBEs/WBEs.



4. Application for Waiver. If the Contractor, consultant, supplier, or vendor does not meet the project goals, the bidder or offer or may seek a partial or total waiver of the project goals. The application for waiver of all or part of the project goals shall include full documentary evidence of the Participant's good faith efforts to meet the project goals and why the request for waiver should be granted. The application shall be notarized and submitted as a part of the bid or offer. Additional explanation, affidavits, exhibits or other materials may be required by the MBE/WBE Program to substantiate good faith efforts. (See the Good Faith Effort Certification, DIV-3, 2 pages, in the attached Bidder's Manual). Waivers may also be granted for an acceptable explanation as to why the goals should be waived.
5. Waiver for Detriment to Public Health, Safety or Financial Welfare. The Director of DEI may waive MBE/WBE Program goals if the same causes a detriment to public health, safety, or the financial welfare of the County. The MBE/WBE Program goals may also be waived in the event available MBE/WBEs provide price quotes which are unreasonably high in that they exceed competitive levels beyond amounts which can be attributed to cost, overhead and profit.

## X. REQUIREMENTS OF PRIME CONTRACTORS

In consideration of the right and privilege to submit a bid or proposal on construction projects and other contracts with Cuyahoga County, at the time of submitting a proposal or bid, each participant shall be required to present appropriate documentation. The documents described below must be completed and signed by each Participant before a proposal or bid can be considered responsive:

- 3) Covenant of Non-Discrimination: Each Participant must submit a duly executed and attested Covenant of Non-Discrimination (DIV-1, found in the attached Bidder's Manual). This written instrument shall contain promises, declarations and/or affirmations made by the Participant. The completed document must contain an original signature and date of signature.
- 4) MBE/WBE Subcontractor Participation Plan: Each Participant must submit a duly executed Subcontractor Participation Plan (DIV-2, found in the attached Bidder's Manual) for each MBE/WBE subcontractor proposed. Copies and/or facsimiles of DIV-2 submitted with bids/proposals are acceptable BUT all required signatures must be dated as indicated. Also, please note the following:
  - a) Certified MBE/WBEs who are bidding as prime contractors **MUST** complete and submit the top portion of Form DIV-2 to guarantee their portion of MBE credit or WBE credit and this can be up to 20% of the MBE participation goal or up to 20% of the WBE participation goal.
  - b) MBE/WBEs with multiple geographical locations shall enter the address and contact information for the geographical locations eligible for Cuyahoga County certification on Form DIV-2.
  - c) Prime vendors are **PROHIBITED** from using MBE/WBE(s) with whom the prime vendor has a familial relationship, joint or co-ownership, common partners, officers, or a shareholder relationship to meet the MBE/WBE Participation Goals. Hence, on Cuyahoga County projects/contracts, any portion of work subcontracted to a MBE/WBE vendor by a prime vendor that meets the above-mentioned criteria will **NOT** count towards the achievement of the established MBE/WBE Participation Goals.

Use of 2<sup>nd</sup> Tier Subcontractors: In the event that a subcontractor portions out work and utilizes the services of a sub-subcontractor or vendor, the prime contractor shall be required to report this use to DEI. For reporting purposes, the prime contractor shall report statistical data for the sub-subcontractor or sub-vendor, including race, gender, business size, area of specialization, dollar value, description of services or products purchased,

and contact information. No MBE/WBE subcontractor will be permitted to subcontract more than 25% of their subcontract work (based on dollar value) without prior approval by DEI.

Other Information and Data: DEI may request additional information and data prior to a contract award. This information may include, but is not limited to, information regarding business ownership of all subcontractors to be utilized on the project, all of which shall reflect the race, gender, location, size, and area of specialization and structure of the identified businesses.

---

**A PARTICIPANT’S FAILURE OR REFUSAL TO PROVIDE INFORMATION AND DATA  
REQUIRED BY THIS PROGRAM AND REQUESTED BY DEI SHALL SUBJECT THE  
PARTICIPANT TO HAVING A  
PROPOSAL OR BID DEEMED NON-RESPONSIVE.**

---

## XI. GOOD FAITH EFFORTS

Aggressive “Good Faith Efforts” to include MBE/WBEs in the procurement process are required of all Participants. These Good Faith Efforts should be in addition to the Participant’s regular and customary solicitation process of contact with potential subcontractors and/or vendors.

Written Notice to MBE/WBEs: To demonstrate good faith efforts, a Participant shall deliver written or electronic notice to potential MBE/WBEs. MBE/WBEs should be contacted not less than one (1) week before the bid or proposal due date. Names, addresses, and telephone numbers for available MBE/WBEs may be obtained by contacting DEI or reviewing the database on the website at <https://opd.cuyahogacounty.us/en-US/listing.aspx>.

The written or electronic notice sent to potential subcontractors or vendors shall contain the following:

- (5) Sufficient information about the plans, specifications, and relevant terms and conditions of the solicitation. This should include information about the work which will be subcontracted or the goods which will be obtained from subcontractors and suppliers;
- (6) A contact person knowledgeable of the project scope documents, within the Participant’s office, to answer questions about the conditions of the contract;
- (7) Information as to the Participant’s bonding requirements (including any offers to assist interested MBE/WBEs in obtaining bonding or insurance); and
- (8) The deadline for price quotations.

Evaluation of Good Faith Efforts: In evaluating good faith efforts, DEI will determine whether the Participant has made reasonable good faith efforts to obtain MBE/WBEs participation as part of its bid or proposal. DEI may evaluate not only the different kinds of efforts made by a Participant, but also the quantity and intensity of those efforts.

DEI will consider a completed Good Faith Effort Certification (DIV-3, 2 pages, found in the attached Bidder’s Manual), as evidence of a Participant’s good faith in trying to obtain MBE/WBE participation in a bid or proposal.

Required Documentation: To demonstrate good faith efforts, Participants shall keep detailed records of all correspondences and responses thereto, emails, logs of all telephone calls made and received regarding the project or contract, confirmation receipts for fax transmissions, receipts from registered or certified mail, copies of advertisements in publications and other media, and other relevant papers required by this Program.

Good Faith Effort Certification: Participant must submit a completed Good Faith Certification (DIV-3, found in the attached Bidder's Manual) ONLY if the MBE Participation Goal and/or the WBE Participation Goal is not met. The completed document must contain an original signature, notarizations, and date of signature. Along with the completed Good Faith Effort Certification, participants shall also submit additional documentation demonstrating a good faith effort (as detailed above in *Required Documentation*).

Administrative Reconsideration: If DEI determines that the apparent successful vendor is non-compliant on meeting the MBE/WBE participation goals and has not demonstrated good faith efforts to obtain MBE/WBE participation, prior to awarding the contract/purchase, the user department shall notify the apparent successful vendor of the determination of non-compliance by emailing the primary contact detailed in the vendor's bid/proposal. The apparent successful vendor shall have the right to request an administrative reconsideration of the non-compliance determination. The administrative reconsideration can be a "no meeting" reconsideration or "meeting" reconsideration (virtual or in-person). The request for an administrative reconsideration must be submitted within three (3) business days of the notification of non-compliance and in the format of an email to DEI at [dei@cuyahogacounty.us](mailto:dei@cuyahogacounty.us). Upon receipt of the request for the administrative reconsideration by the apparent successful vendor, DEI shall forward the request to the Administrative Reconsideration Panel. The panel shall consist of at least three (3) but not more than five (5) County employees appointed by the Cuyahoga County Executive. The request for administrative reconsideration shall detail the pertinent RFB/RFP/RFQ (i.e., title, description...), type of administrative reconsideration requested (i.e., no meeting or meeting), and any written documentation or arguments concerning the issue of non-compliance. DEI shall provide a summary of its Good Faith Effort evaluation and supporting documentation. The Administrative Reconsideration Panel shall publish a schedule that includes deadlines and provides for a frequency of no less than twice per calendar month. The Administrative Reconsideration Panel will evaluate the information provided by the apparent successful vendor and DEI and issue a written decision approving or disapproving of DEI's determination on non-compliance for the matter. A quorum for "no meeting" or "meeting" administrative reconsideration shall be the majority (i.e., greater than 50%) of the appointed panel and an affirmative vote by the majority (i.e., greater than 50%) of the panel present for the administrative reconsideration is required for action. The Administrative Reconsideration Panel shall adopt its own rules of procedure consistent with MBE/WBE Policies and Procedures. The result of the administrative reconsideration is not administratively appealable.

## XII. AWARD OF CONTRACTS

Award of Contract: Proposals/bids may be rejected and projects re-submitted for the sole purpose of attaining goals where no "good faith effort" has been demonstrated. Cuyahoga County reserves the right to determine the action to be taken on the contract if a goal is not met, including rejecting any or all bids or proposals. For RFPs and RFQs, once the scope of work and/or price, terms, and conditions have been finalized but in advance of submission for approval by the pertinent contracting authority, the department shall confirm with DEI that the proposed contract/purchase is compliant with the MBE/WBE participation goals and/or Good Faith Efforts requirements. If an awarded contract is later amended for additional dollars, MBE/WBE subcontractor participation should still reflect the percentage of dollars originally contracted for.

When evaluating a bid to determine the lowest and best bid, the County may consider, in addition to all of the other factors set forth in the instructions to bidders, whether a bid is MBE/WBE compliant; provided, however, that such MBE/WBE compliance shall not be considered if the difference between the MBE/WBE-compliant bid and the lowest responsive bid is more than the price preference specified below.

Lowest Bid Received Range (\$)	Price Preference (%) & Limit	Price Preference (\$)
0 – 500,000	10%	0 – 50,000
500,000.01 – 1,000,000	10% up to max \$80,000 (10-8)	50,000.01 – 80,000
1,000,000.01 – 3,000,000	8% up to max \$210,000 (8-7)	80,000.01 – 210,000
3,000,000.01 – 5,000,000	7% up to max \$250,000 (7-5)	210,000.01 – 250,000
>5,000,000	\$250,000 maximum (≤5)	250,000 maximum

### XIII. MONITORING AND POST-AWARD REPORTING

Department of Equity and Inclusion Authorization to Monitor: DEI shall be authorized to collect from all Participants such data and information as is necessary to monitor this Program. This information may include information as to business ownership, supplier information, subcontractor information, all of which shall reflect the contract information, race, gender, business location, and size of the identified businesses.

DEI shall monitor the participation of MBE/WBEs in the procurement of goods and services for Cuyahoga County. Such monitoring shall include, but is not necessarily limited to, a statistical analysis of each construction trade, business service, professional service, and commodity to determine whether there is utilization of MBE/WBEs in a manner that is proportionate to the established goal.

DEI will provide written reports on an annual basis. DEI’s report shall contain a summary of the purchases and contracts placed with MBE/WBEs for the period and the relative percentage to the total of purchases and contracts for that period.

Participant’s Post-Award Reporting: Participants who are awarded contracts must submit reports on a monthly basis during the course of, at the end of the contract, and as requested by DEI. Participants shall comply with all reporting requirements related to MBE/WBE utilization including, but not limited to, completing on-line reporting of payments made to MBE/WBE subcontractors and other subcontractors. These reports shall summarize the number and dollar amounts of payments made during the term of the contract to subcontractors. At the end of the contract, the final report shall summarize the number and dollar amounts of payments made during the term of the contract to all subcontractors and shall reflect the MBE/WBEs designation of the subcontractor if any. DEI reserves the right to audit a contract for MBE/WBE participation at its discretion during any phase of the project. An audit would include but not be limited to: on site reviews, desk reviews, requests for cancelled checks, requests for invoices, certified payroll reports, etc. Participants shall contact DEI if concerns arise related to its ability to meet the MBE/WBE goals and to seek guidance on available options to meet the goals.

MBE/WBE Subcontractor, Substitutions or Replacements: The prime contractor shall report any replacements or substitutions of the use of MBE/WBE subcontractors to DEI immediately. Prior approval by the Director of DEI is required for MBE/WBE substitutions/replacements. For reporting purposes, the prime contractor shall report to DEI statistical data pertaining to the new subcontractor, including race, gender, business size, area of specialization, and contact information on the MBE/WBE Subcontractor Participation Plan form (DIV-2).

DEI will require a Participant to make good faith efforts to replace a MBE/WBE that is terminated or has otherwise failed to complete its work on a contract with another MBE/WBE to the extent needed to meet the contract MBE/WBE Participation Goal. The Participant must notify DEI immediately, and in writing, of the



MBE/WBE's inability or unwillingness to perform and provide reasonable documentation. The request should include at a minimum: the name of the MBE/WBE firm, the contact, the phone number, the scope of work initially assigned to the MBE/WBE firm, dollars paid to date, percent of scope completed, and the reason for the substitution request including documentation of the MBE/WBE's withdrawal.

The Participant will be given five (5) business days to find a MBE/WBE substitution if the request is granted. In this situation, the Participant will be required to obtain prior approval of the substitute MBE/WBE and to provide copies of MBE/WBE Subcontractor Participation Plan (DIV-2) or documentation of good faith efforts.

If the Participant fails or refuses to comply in the time specified, DEI may issue a recommendation to stop all or part of payment and/or work until satisfactory action has been taken. If the Participant still fails to comply, DEI may issue a recommendation of termination of the contract.

Contractors' Closeout Activity Reports: To further monitor MBE/WBE participation, closeout activity reports will be required from project prime contractors and prime consultants identifying activities of **all** subcontractors and sub-consultants (i.e., non-MBE/WBEs and MBE/WBEs). For all subcontractors and sub-consultants used, the prime contractor shall provide the following information: contact information, ethnicity/race/gender of ownership, summary of scope of work provided, and total payments for said scope of work. This report shall include all modifications/amendments/change orders. The prime contractors/consultants shall provide justification and documentation for MBE/WBE participation shortfalls.

## XIV. GRIEVANCE PROCESS

Any Participant or other party allegedly aggrieved by the provisions of this program may submit a written complaint to DEI who will notify the Grievance Hearing Board. The Grievance Hearing Board is empowered to hear all grievances concerning certification, de-certification, goal complaints, good faith efforts not previously reviewed by the Administrative Reconsideration Panel, and any other grievances called by the provisions of this program.

Grievance Hearing Board: The Grievance Hearing Board consists of the following five (5) members:

- Three (3) appointed by the County Executive, from time-to-time;
- Two (2) County Council Members appointed by the President of County Council

The Grievance Hearing Board meets as required to hear grievances pertaining to the MBE/WBE Program. A meeting quorum of this board consists of four (4) members. An affirmative vote by at least three (3) members is required for action items.

Request for Review: An allegedly aggrieved party may seek review of the DEI determination or decision by filing a written Request for Review with DEI within five (5) days of receipt of the Determination of Non-Compliance, certification denial, recertification denial, or other MBE/WBE decision.

Scheduling the Hearing/Notice of Hearing: Upon receipt of the request for review from the allegedly aggrieved party, DEI shall forward the request for review to the Grievance Hearing Board within three (3) business days of receipt and proceed with scheduling the hearing. Every effort shall be made to hold the hearing no more than twenty (20) days from the date of receipt of the request for review. All external parties shall be sent a written notice by registered mail which shall state the date, time, and place of the hearing.

Hearing: The hearings shall be informal. Participants shall include DEI and the allegedly aggrieved person(s), or a representative of the allegedly aggrieved person. Said hearing shall comply with State of Ohio law relative to the Open Meetings Act.

Decision: The Grievance Hearing Board shall issue a decision at the conclusion of the hearing which may approve or disapprove of DEI's decision or determination.

Exhaustion of Legal Remedies: An aggrieved person or entity must comply with the review process as outlined herein. Once a person or entity has exhausted the administrative remedies outlined in the Program, that person or entity may seek any other statutory, legal, or equitable remedies that may be available. Failure to exhaust all administrative remedies listed above is an affirmative defense to any statutory, legal, or equitable proceeding that may arise.

## XV. SANCTIONS AND PENALTIES FOR NON-COMPLIANCE

Cuyahoga County shall have the authority and power to enforce the provisions of this Program. Failure of a participant to comply with the requirements shall subject it to administrative sanctions. In addition, a violation of this Program shall constitute a material breach of contract enforceable at law or in equity, as will all other contract provisions, including the imposition of penalties. The following sanctions and penalties are established for the enforcement of this Program:

- (7) Determination of Non-Responsiveness: In addition to standard factors in its evaluation, Cuyahoga County may declare a bid or proposal non-responsive where it is determined that a Participant has not filed with Cuyahoga County a duly executed Covenant of Non-Discrimination or any other document as required by this Program.
- (8) Limited Suspension: For falsifications, misrepresentations, deception to obtain a contract, Cuyahoga County may remove a Participant from its list of eligible firms entitled to do business with Cuyahoga County.
- (9) Rejection of Future Proposals: Cuyahoga County may reject any or all future Proposals of a Participant until such time as the Participant demonstrates that it is or shall come into compliance.
- (10) Withholding Payment: Cuyahoga County may withhold payment, until such time as the Participant demonstrates that it is or shall come into compliance.
- (11) Cancellation of Contract: Cuyahoga County may declare a contract null and void where, after such contract has been awarded, an investigation determines that the Participant's documents contain false, fictitious, or fraudulent information.
- (12) Permanent Debarment: For repeated violations, Cuyahoga County may remove a Participant from its list of firms entitled to do business with Cuyahoga County indefinitely.

Guidelines for Imposition of Sanctions: The authority and power for imposition of sanctions and penalties shall lie with County authorities and elected/appointed officials as outlined in the County Charter, County Ordinances, state laws, and federal laws. The recommendation, however, may come from the Grievance Hearing Board or DEI.

- (1) General: Sanctions may be recommended if there is evidence of specific conduct on the part of the Participant that is inconsistent with or in direct opposition to the applicable provisions of this Program. Furthermore, the imposition and enforcement of sanctions shall be consistent with applicable County ordinances, state laws, and federal laws.
- (2) Severity of Sanctions: In determining the length of any suspension, Cuyahoga County shall consider the following factors:
  - (i) Whether the failure to comply with applicable requirements involved intentional conduct or, alternatively, may be reasonably concluded to have resulted from a misunderstanding on the part of the Participant of the duties imposed on them by this Program;
  - (ii) The number of specific incidences of failure by the Participant to comply;
  - (iii) Whether the Participant has been previously suspended;
  - (iv) Whether the Participant has failed or refused to provide Cuyahoga County or DEI with any information required or requested by this Program;
  - (v) Whether the Participant has materially misrepresented any applicable facts in any filing or communication to Cuyahoga County or DEI; and
  - (vi) Whether any subsequent restructuring of the Participant's business or other action has been undertaken to cure the deficiencies in meeting applicable requirements.
- (4) Length of Suspension: Suspensions may be for any length of time. Cuyahoga County may impose suspensions in excess of one year in cases involving intentional or fraudulent misrepresentation or concealment of material facts, multiple acts in breach of the Program, cases where the Participant has been previously suspended, or other similarly situated misconduct.

Prohibition Against False Statements: It shall be unlawful for any person, knowingly and willfully and with intent to mislead or to make any false or fraudulent representations to Cuyahoga County. Cuyahoga County may impose sanctions against any person making such false representation in connection with the MBE/WBE Program.

## **XVI. TRAINING AND OUTREACH STRATEGIES**

Training: Cuyahoga County remains committed to implementing a program that increases the participation of MBE/WBEs in Cuyahoga County's procurement opportunities. To ensure that all Cuyahoga County employees involved in purchasing decisions are appropriately informed, certain personnel would undergo training to increase sensitivity regarding the utilization of MBE/WBEs. Internal training shall ensure that all staff with purchasing authority have the capacity and capability to engage in a consistent, fair, and open procurement process. Training sessions shall occur periodically. The objective of the training is to effectively communicate the importance of the Program and the mechanics of how the Program operates. The training shall address the following topics, among others:

- (v) Understanding the purpose of the Program.
- (vi) Understanding the benefits of doing business with MBEs/WBEs.

- (vii) Understanding how the Program is administered.
- (viii) Developing innovative techniques to increase MBE/WBE participation.

Outreach Program: To ensure that opportunities to participate in Cuyahoga County's contracts are available to the widest feasible universe of willing, available, and qualified businesses, DEI shall develop and engage in outreach designed to increase public awareness of the MBE/WBE Program, MBE/WBE Participation Goals, and MBE/WBE Good Faith Effort Criteria. This outreach may consist of any of the following:

- (6) Public Awareness of the Program. To increase the visibility of DEI and to increase the awareness of the Program, DEI shall disseminate at community events, trade shows, and other appropriate business functions, and publish on its website information describing the Program. Any Program updates shall be published within five (5) business days. This information shall also identify ongoing contracting opportunities. DEI will actively participate in the various advocacy groups to provide constant feedback and to keep MBE/WBEs abreast of the Programs and contracting opportunities.
- (7) Outreach to Contractors and Vendors. DEI shall conduct outreach to vendors and contractors desiring to do business with Cuyahoga County. The intent of this outreach is to support the MBE/WBE Program and promote effective procurement by educating businesses on the MBE/WBE Program, MBE/WBE Goals, and MBE/WBE Good Faith Efforts Criteria
- (8) Outreach to MBE/WBEs. DEI shall assist the MBE/WBE businesses by providing workshops and seminars on the MBE/WBE Program, MBE/WBE Goals, MBE/WBE Good Faith Efforts Criteria, and Cuyahoga County's procurement policies and procedures.
- (9) 24-month Purchasing and Contracting Forecast. DEI shall work with Cuyahoga County departments and agencies to prepare and update biannually a 24-month purchasing and contracting forecasts (including annually reoccurring purchases). For the initial forecast and each biannual update of the forecast, County departments/agencies shall compile a purchasing and contracting forecast for the upcoming 24-month period and submit said forecast to DEI. The forecast shall include for each item the originating/lead department, a brief description, estimated amount, and estimated solicitation/advertisement date. The forecast shall also detail purchases and/or contracts that will be procured using the Small Business Set Aside Program which enables County certified small business enterprises to compete against each other for the item award. DEI shall combine the individual forecasts into one forecast and post the combined forecast on the DEI website biannually.

In addition, County departments and agencies shall coordinate with DEI to expand the Small Business Set Aside Program. Specifically, as part of the creation and biannual updates of their forecasts, County departments and agencies shall provide a forecast of contracts and purchases that will be procured using the Small Business Set Aside Program. The County departments and agencies and DEI shall use the following criteria to evaluate and select the contracts and purchases for procurement using the Small Business Set Aside Program:



<b>SELECTION CRITERIA</b>	<b>SUMMARY</b>
<b>FUNDING SOURCE REQUIREMENTS &amp; RESTRICTIONS</b>	County agencies leverage County funds with a multitude of other funding sources (i.e., federal, state, grants, loans...). This enables the County to maximize the return on its investments. However, some of the funding sources may have requirements that will limit the County's ability to fully enact its diversity/inclusion initiatives. When evaluating the eligibility of contracts or services for the SBE Set Aside Program, funding source requirements and restrictions will be assessed.
<b>SCOPE OF WORK</b>	When evaluating the eligibility of contracts or services for the SBE Set Aside Program, the scope of work will be assessed. Contracts or services selected will: <ul style="list-style-type: none"> <li>• be typical of the industry in size and scope</li> <li>• be of simpler or of typical complexity</li> <li>• have typical/standard delivery requirements</li> <li>• have typical periods of performance for the industry</li> </ul>
<b>COMPETITIVE ENVIRONMENT</b>	While providing opportunities for SBE vendors to participate in the County procurement process, the County must still maximize the return on its resources. As such, when evaluating the eligibility of contracts or services for the SBE Set Aside Program, at the time of selection, contracts or services must have at least three (3) County certified SBE vendors that provide the scope of work/goods being procured. The size of the pool of pertinent County certified SBE vendors will be re-confirmed at the time of advertisement.
<b>PERFORMANCE BOND AND INSURANCE REQUIREMENTS</b>	Performance bond and insurance requirements are frequently mentioned as obstacles to small businesses in participating in government contracts. When evaluating the eligibility of contracts or services for the SBE Set Aside Program, contracts, or services with lower than or typical performance bond and insurance requirements will be selected.

- (10) 30-day minimum Bid/RFP/RFQ Solicitation/Advertisement Period. All reasonable efforts shall be made to post formal bids/RFPs/RFQs for goods and/or services on the County website for no fewer than 30 days prior to the bid/RFP/RFQ opening. Reasonable efforts include, but are not limited to, County departments and agencies initiating the procurement process for bids, RFPs, and RFQs in ample time to complete pre-advertisement tasks (includes completion of procurement specifications, developing estimated costs by NIGP code for the pertinent scopes of work for the procurement, determination of diversity goals by DEI, finalizing the specification packet...) to enable the posting of bids, RFPs, and RFQs for no fewer than 30 days prior to the bid/RFP/RFQ opening date. Reasonable efforts include, but are not limited to, County departments and agencies exhausting other options (such as working to accelerate the internal bid/proposal/qualification review process and contract negotiation) to meet contract and purchase award deadlines before shortening the solicitation/advertisement period. In brief, shortening the solicitation/advertisement period to less than 30 days shall not be the default, initial, or only option evaluated and/or exercised to accelerate the procurement timeline.

## XVII. BOND WAIVER PROGRAM

Cuyahoga County's Department of Law's Risk Management Division administers a bond waiver program in accordance with County Code Section 508.02.

## XVIII. SEVERABILITY

If any of the provisions set forth in this Program or any section, subsection, paragraph, sentence, clause, phrase, or word thereof shall be found to be invalid, illegal, or unenforceable for any reason, the application of the remainder of this Program shall not be affected by such invalidity.

## XIX. DEFINITIONS

For the purpose of this Program, the following words, terms, phrases, and abbreviations shall have the following meanings:

“Administrative Reconsideration Panel”: shall mean the panel of County employees appointed by the County Executive that at the request of the apparent successful vendor reviews a non-compliance determination made by DEI.

“Certification”: shall mean the qualifying process that ensures buyers and local, state, and federal agencies that a particular business is eligible to become a part of a pool of vendors identified for the purpose of increasing opportunities with respect to contracts and purchases awarded by Cuyahoga County.

“Commercially Useful Function”: shall mean the performance of real and actual services by a Participant who contracts with Cuyahoga County, or subcontracts with another business enterprise which contracts with Cuyahoga County. A business enterprise serving as a “conduit”, “front” or “pass-through” for another business shall not be deemed to perform a commercially useful function. In determining whether a business is performing a commercially useful function, factors, including but not limited to the following, will be considered:

- i) The nature and amount of work contracted;
- ii) Whether the MBE/WBE has the skill and expertise to perform work for which it has been certified;
- iii) Whether the MBE/WBE actually performs, manages, and supervises the work;
- iv) Whether the MBE/WBE intends to purchase commodities and/or services from a non-MBE/WBE and simply resell same to the general or prime contractor for the purpose of allowing those commodities and/or services to be counted towards the fulfillment of a goal;
- v) Standard industry practices relating to the use of the subcontractors. Consistent with standard industry practices, a MBE/WBE subcontractor may enter into second tier subcontracts. If a MBE/WBE subcontractor subcontracts a significantly greater portion of the work of its

subcontract to a non-MBE/WBE inconsistent with standard industry practices, the MBE/WBE subcontractor shall be presumed not to be performing a commercially useful function.

**“Compliance”**: shall mean the condition existing when a Participant has met the requirements of this Program.

**“Conduit”**: shall mean a business which purchases goods or services that are not normally purchased or sold as part of its daily business from another business(es) for the sole purpose of resale to Cuyahoga County or a contractor doing business with Cuyahoga County.

**“Contract”**: shall mean any mutually binding legal obligation of Cuyahoga County created to acquire some good and/or service from one or more Participants, which is paid or which is to be paid for, in whole or in part, with monetary appropriations of Cuyahoga County. In this context, the terms “contracting”, “purchasing”, and “procurement” are synonymous and refer to the process or processes under which Cuyahoga County undertakes such acquisitions.

**“Cuyahoga County”**: shall mean the government agency which provides public contracting to increase quality of life in the County.

**“Covenant of Non-Discrimination”**: shall mean, collectively, one or more contractual affirmative promises (1) to adopt the policies of Cuyahoga County relating to the participation of MBE/WBEs in the procurement process; (2) to undertake certain good faith efforts to solicit SBEs participation; and (3) not to otherwise engage in discriminatory conduct against MBE/WBEs.

**“DEI”**: shall mean the Department of Equity and Inclusion, which is responsible for administration of the MBE/WBE Program.

**“Department”**: Shall mean a department, division or elected official’s office which solicits bids and/or proposals through the Purchasing Department.

**“Goal”**: shall mean an aspirational effort to attain a certain level of MBE/WBE participation on contracts awarded by the Cuyahoga County based on subcontracting opportunities and available MBE/WBEs to perform.

**“Good Faith Efforts”**: shall mean the aggressive actions of a Participant undertaken in earnest to achieve MBE/WBE goals and ensure that it does not discriminate in its contracting practices.

**“Independent”**: shall mean that with respect to the ownership, control, and activity of a MBE/WBE, the business shall operate separate and apart from the ownership, control or undue influence of another business owned and controlled by one or more non-MBE/WBEs.

**“Joint Venture”**: shall mean an association of two or more independent persons, partnerships, corporations (or any combination of them) formed, consistent with the laws of the State of Ohio. This joint venture would carry out a single, for-profit business enterprise, for which the parties combine their property, capital, efforts, skills, and knowledge, and in which the MBE/WBE is responsible for a distinct, clearly defined portion of the work of the contract and whose share in the capital contribution, control, management, risks, and profits of the joint venture are commensurate with its ownership interest.

**“Minority Business Enterprise” (“MBE”)**: shall mean an individual, domestic corporation, sole proprietorship, partnership, joint venture, entity, or company that is at least 51% owned by one or more individuals who are African American, Hispanic American, Native American, Asian-Pacific American, or Asian-Indian American; and whose management and daily business operations are controlled by one or more of these owners as determined by DEI.

“Manufacturer”: shall mean an individual (or individuals) who owns, operates, or maintains a factory or establishment that produces on the premises the components, materials, or supplies obtained by the Participant or Cuyahoga County.

“Non-Compliance”: shall mean the condition that exists when a Participant has failed to meet the requirements of this Program.

“Office”: shall mean that a business enterprise with an established place of business in the Cuyahoga County area at which one or more of its employees is regularly based and that such place of business has a substantial role in the business’ performance of a commercially useful function as herein defined. A location utilized solely as a post office box, mail drop or telephone message center or any combination thereof, with no other substantial work function, shall not constitute a significant business presence.

“Participant”: shall mean any contractor, vendor, supplier, or other person, partnership, joint venture, corporation, or other business entity that submits a bid or proposal to Cuyahoga County or expressed interest in submitting a bid or proposal in response to competitive solicitation issued by Cuyahoga County or who has been awarded a contract by Cuyahoga County.

“Project Owner”: shall mean the representative of Cuyahoga County that enters into agreement or contracts with a firm for services or supplies or any other item which shall cause a disbursement of funds from Cuyahoga County.

“Proposal”: shall mean a quotation, proposal, bid or offer by a Participant to perform or provide labor, materials, supplies, or services to Cuyahoga County in response to competitive solicitation issued by Cuyahoga County.

“Purchasing Department”: shall mean the Cuyahoga County department responsible for the purchase of goods and services required for all offices of Cuyahoga County, other than separate political subdivisions.

“Race/Gender-Conscious”: shall mean any governmental or legislative policy or programmatic action that uses race or gender as criteria for participation. The use of a MBE or WBE goal is a primary example of a race-conscious measure.

“Race/Gender-Neutral”: shall mean any governmental or legislative policy or a programmatic action in which race or gender is not among, or the specific criteria for participation. While benefiting MBEs and WBEs, it is not solely focused on MBE or WBE firms and can be used to assist all small businesses. For example, small business outreach programs, technical assistance programs, mobilization fees, bonding assistance and prompt payment provisions can assist a wide variety of small businesses, not just MBEs and WBEs.

“Responsible”: shall reference a Participant’s integrity, compliance with public policy, and record of past performance and financial and technical resources. A Participant must meet certain requirements to be considered a responsible bidder.

“Responsive”: shall mean that a bid must comply in all material respects, both to the method and timeliness of submission and to the substance of any resulting contract, so that all Participants may stand on an equal footing and the integrity of the competitive bidding system may be maintained.

“Small Business Enterprise” (“SBE”): shall refer to a firm that is certified by DEI, submitted an application and has been accepted as a firm eligible to take advantage of affirmative action efforts established in the Small Business Enterprise Program.

“Underutilization”: shall mean the percentage of dollars spent by Cuyahoga County with MBE/WBEs which is less than would be expected based on MBE/WBE availability in the County.

“Women Business Enterprise” (“WBE”): means an individual, domestic corporation, sole proprietorship, partnership, joint venture, entity, or company that is at least 51% owned by one or more women and whose management and daily business operations are controlled by one or more of these owners as determined by DEI.

DRAFT



## **RQ**

# **BIDDERS' MANUAL**

## Minority Business Enterprise (MBE) and Women Business Enterprise (WBE) Program

The goal of the MBE/WBE Program is to support and encourage inclusion by creating positive partnerships in County contracting and other procurement opportunities. The MBE/WBE Program will achieve this goal by providing and supporting opportunities for MBE/WBEs to grow and thereby compete effectively in the general environment for contracting opportunities.

### THE MBE/WBE PARTICIPATION GOALS FOR THIS BID/PROPOSAL:

MARK "X" for applicable category	CATEGORY	GOALS
	Construction	MBE: % WBE: %
	Architecture & Engineering	MBE: % WBE: %
	Professional Services	MBE: % WBE: %
	Other Services	MBE: % WBE: %
	Goods and Supplies	MBE: % WBE: %

Cuyahoga County  
Is an Equal Opportunity Employer

# MBE/WBE BIDDERS' MANUAL

## TABLE OF CONTENTS

Section I.	MBE/WBE Certifications	Page 3
Section II.	SBE Set Aside Program	Page 3
Section III.	MBE/WBE Participation Goal	Page 3
Section IV.	Mandatory Bidding Requirements for Prime Contractors	Page 4
Section V.	Good Faith Efforts	Page 5
Section VI.	Award of Contracts	Page 6
Section VII.	Monitoring and Post-Award Reporting	Page 7

### REQUIRED FORMS:

- Covenant of Non-Discrimination (DIV-1)
- MBE/WBE Subcontractor Participation Plan (DIV-2)
- Good Faith Effort Certification (DIV-3, 2 pages)
- Sample of Completed MBE/WBE forms (4 pages)

# **INSTRUCTIONS TO BIDDERS**

## **II. MBE/WBE Certifications**

Only those certified by the Cuyahoga County's Department of Equity and Inclusion (DEI) shall be eligible for the fulfillment of the MBE/WBE participation goal. MBE and/or WBE listings may be obtained from the Department of Equity and Inclusion (DEI). If a MBE and/or WBE elects to compete for County business without being certified by Cuyahoga County as such, they may do so, but any bid/proposal submitted will not be counted towards fulfillment of the MBE/WBE participation goals.

A MBE/WBE desiring certification with Cuyahoga County must complete the certification application. MBE/WBE applications may be obtained from the:

Department of Equity and Inclusion  
2079 East Ninth St., 2<sup>nd</sup> Floor  
Cleveland, Ohio 44115  
(216) 443-7230

## **II. SBE Set Aside Program**

The goal of the Small Business Enterprise Set Aside Program is to support small businesses by creating contracts and other procurement opportunities exclusively for participation by Cuyahoga County Certified small business enterprise. The Small Business Enterprise Set Aside Program will achieve and support opportunities for small firms to grow and thereby compete effectively in the general environment for contracting opportunities. This program may also include MBE/WBE goals.

## **III. MBE/WBE Participation Goal**

The MBE/WBE Participation goals can be achieved in the following manner(s):

4. A prime vendor subcontracts with one or more certified MBE/WBEs to meet or exceed the goal;
5. A prime vendor subcontracts with one or more certified companies in an amount short of the goal, but submits a complete Good Faith Effort (further described below);
6. A certified MBE/WBE company who bids as a prime contractor subcontracts a portion of the work to another certified MBE/WBE. Certified MBE/WBEs who are bidding as prime contractors will receive a credit for up to 20% of the MBE participation goal or for up to 20% of the WBE participation goal. However, the certified MBE/WBE must secure additional certified MBE/WBE subcontractor participation and/or seek a waiver based on Good Faith Effort (further described below) for any remaining balance of the MBE/WBE goals.



## **IV. Mandatory Bidding Requirements for Prime Contractors**

In consideration of the right and privilege to submit a bid or proposal on construction projects and other contracts with Cuyahoga County, at the time of submitting a proposal or bid, each participant shall be required to present appropriate documentation. The documents described below must be completed and signed by each Participant before a proposal or bid can be considered responsive:

- 3) **Covenant of Non-Discrimination**: Each Participant must submit a duly executed and attested Covenant of Non-Discrimination (DIV-1, found in the attached Bidder's Manual). This written instrument shall contain promises, declarations and/or affirmations made by the Participant. The completed document must contain an original signature and date of signature.
- 4) **MBE/WBE Subcontractor Participation Plan**: Each Participant must submit a duly executed Subcontractor Participation Plan (DIV-2, found in the attached Bidder's Manual) for each MBE/WBE subcontractor proposed. Copies and/or facsimiles of DIV-2 submitted with bids/proposals are acceptable BUT all required signatures must be dated as indicated. Also, please note the following:
  - a) Certified MBE/WBEs who are bidding as prime contractors MUST complete and submit the top portion of Form DIV-2 to guarantee their portion of MBE credit or WBE credit and this can be up to 20% of the MBE participation goal or up to 20% of the WBE participation goal.
  - b) MBE/WBEs with multiple geographical locations shall enter the Cuyahoga County address and contact information on Form DIV-2.
  - c) Prime vendors are **PROHIBITED** from using MBE/WBE(s) with whom the prime vendor has a familial relationship, joint or co-ownership, common partners, officers, or a shareholder relationship to meet the MBE/WBE Participation Goals. Hence, on Cuyahoga County projects/contracts, any portion of work subcontracted to a MBE/WBE vendor by a prime vendor that meets the above-mentioned criteria will **NOT** count towards the achievement of the established MBE/WBE Participation Goals.

**Use of 2<sup>nd</sup> Tier Subcontractors**: In the event that a subcontractor portions out work and utilizes the services of a sub-subcontractor or vendor, **the prime contractor** shall be required to report this use to DEI. For reporting purposes, the prime contractor shall report statistical data for the sub-subcontractor or sub-vendor, including race, gender, business size, area of specialization, dollar value, description of services or products purchased, and contact information. No MBE/WBE subcontractor will be permitted to subcontract more than 25% of their subcontract work (based on dollar value) without prior approval by DEI.

**Other Information and Data**: DEI may request additional information and data prior to a contract award. This information may include, but is not limited to, information regarding business ownership of all subcontractors to be utilized on the project, all of which shall reflect the race, gender, location, size, and area of specialization and structure of the identified businesses.

---

**A PARTICIPANT'S FAILURE OR REFUSAL TO PROVIDE INFORMATION AND DATA REQUIRED BY THIS PROGRAM AND REQUESTED BY DEI SHALL SUBJECT THE PARTICIPANT TO HAVING A PROPOSAL OR BID DEEMED NON-RESPONSIVE.**

---

## **V. Good Faith Efforts**

Aggressive “Good Faith Efforts” to include MBE/WBEs in the procurement process are required of all Participants. These Good Faith Efforts should be in addition to the Participant’s regular and customary solicitation process of contact with potential subcontractors and/or vendors.

Written Notice to MBE/WBEs: To demonstrate good faith efforts, a Participant shall deliver written or electronic notice to potential, MBE/WBEs. MBE/WBEs should be contacted not less than one (1) week before the bid or proposal due date. Names, addresses, and telephone numbers for available MBE/WBEs may be obtained by contacting DEI or reviewing the database on the website at <https://opd.cuyahogacounty.us/en-US/listing.aspx> .

The written or electronic notice sent to potential subcontractors or vendors shall contain the following:

- (5) Sufficient information about the plans, specifications, and relevant terms and conditions of the solicitation. This should include information about the work which will be subcontracted or the goods which will be obtained from subcontractors and suppliers;
- (6) A contact person knowledgeable of the project scope documents, within the Participant’s office, to answer questions about the conditions of the contract;
- (7) Information as to the Participant’s bonding requirements; and
- (8) The deadline for price quotations.

Evaluation of Good Faith Efforts: In evaluating good faith efforts, DEI will determine whether the Participant has made reasonable good faith efforts to obtain MBE/WBE participation as part of its bid or proposal. DEI may evaluate not only the different kinds of efforts made by a Participant, but also the quantity and intensity of those efforts.

DEI will consider a completed Good Faith Effort Certification (DIV-3, 2 pages, found in the attached Bidder’s Manual), as evidence of a Participant’s good faith in trying to obtain MBE/WBE participation in a bid or proposal.

Required Documentation: To demonstrate good faith efforts, Participants shall keep detailed records of all correspondences and responses thereto, emails, logs of all telephone calls made and received regarding the project or contract, confirmation receipts for fax transmissions, receipts from registered or certified mail, copies of advertisements in publications and other media, and other relevant papers required by this Program.

Good Faith Effort Certification: Participant must submit a completed Good Faith Certification (DIV-3, found in the Bidder’s Manual) ONLY if the MBE Participation Goal and/or the WBE Participation Goal is not met. Additional documentation demonstrating a good faith effort must accompany the checklist (as detailed above in *Required Documentation*). The completed document must contain an original signature, notarizations, and date of signature.

**Administrative Reconsideration:** If DEI determines that the apparent successful vendor is non-compliant on meeting the MBE/WBE participation goals and has not demonstrated good faith efforts to obtain MBE/WBE participation, prior to awarding the contract/purchase, the user department shall notify the apparent successful vendor of the determination of non-compliance by emailing the primary contact detailed in the vendor's bid/proposal. The apparent successful vendor shall have the right to request an administrative reconsideration of the non-compliance determination. The administrative reconsideration can be a "no meeting" reconsideration or "meeting" reconsideration (virtual or in-person). The request for an administrative reconsideration must be submitted within three (3) business days of the notification of non-compliance and in the format of an email to DEI at [dei@cuyahogacounty.us](mailto:dei@cuyahogacounty.us). Upon receipt of the request for the administrative reconsideration by the apparent successful vendor, DEI shall forward the request to the Administrative Reconsideration Panel. The panel shall consist of at least three (3) but not more than five (5) County employees appointed by the Cuyahoga County Executive. The request for administrative reconsideration shall detail the pertinent RFB/RFP/Rfq (i.e., title, description...), type of administrative reconsideration requested (i.e., no meeting or meeting), and any written documentation or arguments concerning the issue of non-compliance. DEI shall provide a summary of its Good Faith Effort evaluation and supporting documentation. The Administrative Reconsideration Panel shall publish a schedule that includes deadlines and provides for a frequency of no less than twice per calendar month. The Administrative Reconsideration Panel will evaluate the information provided by the apparent successful vendor and DEI and issue a written decision approving or disapproving of DEI's determination on non-compliance for the matter. A quorum for "no meeting" or "meeting" administrative reconsideration shall be the majority (i.e., greater than 50%) of the appointed panel and an affirmative vote by the majority (i.e., greater than 50%) of the panel present for the administrative reconsideration is required for action. The Administrative Reconsideration Panel shall adopt its own rules of procedure consistent with MBE/WBE Policies and Procedures. The result of the administrative reconsideration is not administratively appealable.

## **VI. Award of Contracts**

**Award of Contract:** Proposals/bids may be rejected and projects re-submitted for the sole purpose of attaining goals where no "good faith effort" has been demonstrated. Cuyahoga County reserves the right to determine the action to be taken on the contract if a goal is not met, including rejecting any or all bids or proposals. For RFPs and RFQs, once the scope of work and/or price, terms, and conditions have been finalized but in advance of submission for approval by the pertinent contracting authority, the department shall confirm with DEI that the proposed contract/purchase is compliant with the MBE/WBE participation goals and/or Good Faith Efforts requirements. If an awarded contract is later amended for additional dollars, MBE/WBE subcontractor participation should still reflect the percentage of dollars originally contracted for.

When evaluating a bid to determine the lowest and best bid, the County may consider, in addition to all of the other factors set forth in the instructions to bidders, whether a bid is compliant with the applicable MBE/WBE goals, provided, however, that such compliance shall not be considered if the difference between the MBE/WBE-compliant bid and the lowest responsive bid is more than the price preference specified below.

Lowest Bid Received Range (\$)	Price Preference (%) & Limit	Price Preference (\$)
0 – 500,000	10%	0 – 50,000
500,000.01 – 1,000,000	10% up to max \$80,000 (10-8)	50,000.01 – 80,000
1,000,000.01 – 3,000,000	8% up to max \$210,000 (8-7)	80,000.01 – 210,000
3,000,000.01 – 5,000,000	7% up to max \$250,000 (7-5)	210,000.01 – 250,000
>5,000,000	\$250,000 maximum ( $\leq 5$ )	250,000 maximum

## **VII. Monitoring and Post-Award Reporting**

Department of Equity and Inclusion Authorization to Monitor: DEI shall be authorized to collect from all Participants such data and information as is necessary to monitor this Program. This information may include information as to business ownership, supplier information, subcontractor information, all of which shall reflect the contract information, race, gender, business location, and size of the identified businesses.

DEI shall monitor the participation of MBE/WBEs in the procurement of goods and services for Cuyahoga County. Such monitoring shall include, but is not necessarily limited to, a statistical analysis of each construction trade, business service, professional service, and commodity to determine whether there is utilization of MBE/WBEs in a manner that is proportionate to the established goal.

DEI will provide written reports on an annual basis. DEI's report shall contain a summary of the purchases and contracts placed with MBE/WBEs for the period and the relative percentage to the total of purchases and contracts for that period.

Participant's Post-Award Reporting: Participants who are awarded contracts must submit reports on a monthly basis during the course of, at the end of the contract, and as requested by DEI. Participants shall comply with all reporting requirements related to MBE/WBE utilization including, but not limited to, completing on-line reporting of payments made to MBE/WBE subcontractors and other subcontractors. These reports shall summarize the number and dollar amounts of payments made during the term of the contract to subcontractors. At the end of the contract, the final report shall summarize the number and dollar amounts of payments made during the term of the contract to all subcontractors and shall reflect the MBE/WBEs designation of the subcontractor if any. DEI reserves the right to audit a contract for MBE/WBE participation at its discretion during any phase of the project. An audit would include but not be limited to: on site reviews, desk reviews, requests for cancelled checks, requests for invoices, certified payroll reports, etc. Participants shall contact DEI if concerns arise related to its ability to meet the MBE/WBE goals and to seek guidance on available options to meet the goals.

MBE/WBE Subcontractor Substitutions or Replacements: The prime contractor shall report any replacements or substitutions of the use of MBE/WBE subcontractors to DEI immediately. Prior approval by the Director of DEI is required for MBE/WBE substitutions/replacements. For reporting purposes, the prime contractor shall report to DEI statistical data pertaining to the new subcontractor, including race, gender, business size, area of specialization, and contact information on the MBE/WBE Subcontractor Participation Plan form (DIV-2).

DEI will require a Participant to make good faith efforts to replace a MBE/WBE that is terminated or has otherwise failed to complete its work on a contract with another MBE/WBE to the extent needed to meet the contract MBE/WBE Participation Goal. The Participant must notify DEI immediately, and in writing, of the MBE/WBE's inability or unwillingness to perform and provide reasonable documentation. The request should

include at a minimum: the name of the MBE/WBE firm, the contact, the phone number, the scope of work initially assigned to the MBE/WBE firm, dollars paid to date, percent of scope completed, and the reason for the substitution request including documentation of the MBE/WBE's withdrawal.

The Participant will be given five (5) business days to find a MBE/WBE substitution if the request is granted. In this situation, the Participant will be required to obtain prior approval of the substitute MBE/WBE and to provide copies of MBE/WBE Subcontractor Participation Plan (DIV-2) or documentation of good faith efforts.

If the Participant fails or refuses to comply in the time specified, DEI may issue a recommendation to stop all or part of payment and/or work until satisfactory action has been taken. If the Participant still fails to comply, DEI may issue a recommendation of termination of the contract.

Contractors' Closeout Activity Reports: To further monitor MBE/WBE participation, closeout activity reports will be required from project prime contractors and prime consultants identifying activities of **all** subcontractors and sub-consultants (i.e., non-MBE/WBEs and MBE/WBEs). For all subcontractors and sub-consultants used, the prime contractor shall provide the following information: contact information, ethnicity/race/gender of ownership, summary of scope of work provided, and total payments for said scope of work. This report shall include all modifications/amendments/change orders. The prime contractors/consultants shall provide justification and documentation for MBE/WBE participation shortfalls.

DRAFT

## **REQUIRED DOCUMENTS**

The following forms regarding the MBE/WBE Program must be completed and submitted with bids/proposals:

- COVENANT OF NON-DISCRIMINATION (DIV-1)
- MBE/WBE SUBCONTRACTOR PARTICIPATION PLAN (DIV-2)
- GOOD FAITH EFFORT CERTIFICATION (DIV-3, 2 PAGES)

DRAFT

COVENANT OF NON-DISCRIMINATION

(MUST be completed and submitted with ALL bids or proposals)

Know All Men By These Presents, that I/we, ( \_\_\_\_\_ ),  
Name(s)  
( \_\_\_\_\_ ), ( \_\_\_\_\_ ),  
Title(s) Name of Company

(hereinafter "Company"), in consideration of the privilege to submit Bids/Proposals on contracts funded, in whole or in part, by Cuyahoga County, hereby consents, covenants, and agrees as follows:

(1) No person shall be excluded from participation in, denied the benefit of, or otherwise discriminated against on the basis of race, creed, color, national origin, handicap, sex, age, marital status, or sexual orientation in connection with any Bid/Proposal submitted to Cuyahoga County or the performance of any contract resulting from;

(2) That it is and shall be the policy of this Company to provide equal opportunity to all business persons seeking to contact or otherwise interested in contracting with this Company, including various eligible Minority Business Enterprises and Women Business Enterprises (hereinafter "MBE/WBEs");

(3) In connection herewith, I/We acknowledge and warrant that this Company has been made aware of, understands, and agrees to make a Good Faith Effort to solicit MBE/WBEs to do business with this Company;

(4) That the Covenant of Non-Discrimination as made and set forth herein shall be continuing in nature and shall remain in full force and effect without interruption;

(5) That the Covenant of Non-Discrimination as made and set forth herein shall be and are hereby deemed to be made a part of, and incorporated by reference into, any contract or portion thereof which this Company may hereafter obtain; and

(6) That the failure of this Company to satisfactorily discharge any of the Covenant of Non-Discrimination as made and set forth herein shall constitute a material breach of contract entitling Cuyahoga County to declare the contract in default and to exercise any and all applicable rights and remedies, including but not limited to, cancellation of the contract, termination of the contract, suspension and debarment from future contracting opportunities, and withholding and/or forfeiture of compensation due and owing on a contract.

\_\_\_\_\_  
(Original Signature of Company Representative Identified Above)

\_\_\_\_\_  
(Date)

**MBE/WBE SUBCONTRACTOR PARTICIPATION PLAN**  
**(MUST be submitted for EACH MBE/WBE Subcontractor Proposed)**

(A) TOTAL AMOUNT OF OVERALL CONTRACT BID/PROPOSAL \$ \_\_\_\_\_

BUSINESS NAME OF PRIME BIDDER \_\_\_\_\_

ADDRESS \_\_\_\_\_

CITY \_\_\_\_\_ STATE \_\_\_\_\_ ZIP CODE \_\_\_\_\_

TELEPHONE (\_\_\_\_) \_\_\_\_\_ E-MAIL \_\_\_\_\_

PRIME FIRM OWNED BY: NON-MBE/WBE/SBE  SBE SMALL BUSINESS ENTERPRISE   
MBE MINORITY BUSINESS ENTERPRISE  WBE WOMEN BUSINESS ENTERPRISE

(B) AMOUNT TO BE SUBCONTRACTED TO MBE/WBE (PLEASE CIRCLE ONE): \$ \_\_\_\_\_ PERCENT OF TOTAL OVERALL CONTRACT BID [(B)/(A)]: \_\_\_\_\_ %

SCOPE OF WORK PROVIDED BY MBE/WBE: \_\_\_\_\_

PRIME BIDDER'S NAME \_\_\_\_\_ TITLE \_\_\_\_\_  
(TYPE OR PRINT)

PRIME BIDDER'S SIGNATURE \_\_\_\_\_  
(DATE OF SIGNATURE)

**MBE/WBE SUBCONTRACTOR TO BE UTILIZED**  
(MUST BE CERTIFIED BY THE CUYAHOGA COUNTY DEPARTMENT OF EQUITY AND INCLUSION)

NAME OF SUBCONTRACTOR \_\_\_\_\_

ADDRESS \_\_\_\_\_

CITY \_\_\_\_\_ STATE \_\_\_\_\_ ZIP CODE \_\_\_\_\_  
TELEPHONE AREA CODE (\_\_\_\_) \_\_\_\_\_  
 SMALL BUSINESS SBE  MINORITY BUSINESS MBE  WOMEN BUSINESS WBE

**\*\*\*\*\*NOTE: MUST BE A COUNTY CERTIFIED MBE/WBE \*\*\*\*\***

THE UNDERSIGNED HEREWITH AGREES TO SUBCONTRACT WITH THE ABOVE NAMED BIDDER FOR THE ABOVE SAID SERVICE(S) OR SUPPLY(IES) TO BE FURNISHED TO THE COUNTY.

SUBCONTRACTOR'S NAME \_\_\_\_\_ TITLE \_\_\_\_\_  
(TYPE OR PRINT)

SUBCONTRACTOR'S SIGNATURE \_\_\_\_\_  
(DATE OF SIGNATURE)



### GOOD FAITH EFFORT CERTIFICATION

(Must be submitted with bids/proposals NOT meeting the MBE/WBE goals or requesting full or partial waiver)

Pursuant to the requirements for bidders under the MBE/WBE Program, and in consideration of the privilege to submit bids/proposals funded, in whole or in part, by Cuyahoga County,

I/We, ( \_\_\_\_\_ ), ( \_\_\_\_\_ ) of ( \_\_\_\_\_ )  
Name(s) of Person(s) Signing Below Title(s) Company Name

attest that I/We have exercised the following good faith efforts in addition to my/our regular and customary solicitation process: (Check ALL that apply and complete as indicated)

- I/We are requesting a FULL/PARTIAL WAIVER of the MBE  WBE  Participation Goal for the following reason(s): \_\_\_\_\_  
\_\_\_\_\_
- I/We are a non-profit agency and are requesting a FULL WAIVER of the MBE/WBE Goal. **(MUST SUBMIT/ATTACH PROOF)**
- I/We have contacted DEI or website to obtain a list of MBE/WBEs appropriate to the bid/proposal.
- I/We delivered written notice to available certified MBE/WBEs for each potential subcontracting or supply category in the contract AND all potential subcontractors or vendors which requested information on the contract. **(MUST SUBMIT/ATTACH PROOF)**
- I/We have provided all potential subcontractors or vendors with adequate information as to plans, specifications, relevant terms and conditions of the contract, bonding requirements, and the last date and time for receipt of price quotations. **(MUST SUBMIT/ATTACH PROOF)**
- I/We have attended the pre-bid/proposal conference.
- I/We have **provided a written explanation for rejection of any potential** MBE/WBE subcontractor or vendor to DEI. When the MBE/WBE subcontractor rejection is due to unreasonably high pricing, I/We have provided supporting documentation.
- I/We have actively solicited, through sending letters, emails or initiating personal contact, MBE/WBEs in all feasible and appropriate categories providing subcontracting opportunities for the contract under consideration. **(MUST SUBMIT/ATTACH PROOF)**
- I/We have utilized the services of available community organizations and associations, contractors' groups, and trade associations known to publicize contracting and procurement opportunities, for the purpose of obtaining assistance in the contacting and recruitment of MBE/WBEs for the Cuyahoga County contract under consideration. **(MUST SUBMIT/ATTACH PROOF)**
- I/We have conducted discussions with interested MBE/WBEs in good faith and provided the same willingness to assist MBE/WBEs as has been extended to any other similarly situated subcontractor.
- I/We have taken steps to ensure that all labor supervisors, superintendents, and other on-site supervisory personnel are aware of and carry out the obligation to maintain a non-discriminatory work environment, free of harassment, intimidation and coercion at all construction sites, offices and other facilities to which employees are assigned to work.



DRAFT

\*\*\*\* SAMPLE FORMS \*\*\*\*

COVENANT OF NON-DISCRIMINATION

(MUST be completed and submitted with ALL bids or proposals)

Know All Men By These Presents, that I/we, ( John Doe ),  
Name(s)  
( President, Owner ), ( ABC Company, Inc. ),  
Title(s) Name of Company

(hereinafter "Company"), in consideration of the privilege to submit Bids/Proposals on contracts funded, in whole or in part, by Cuyahoga County, hereby consents, covenants, and agrees as follows:

(1) No person shall be excluded from participation in, denied the benefit of, or otherwise discriminated against on the basis of race, creed, color, national origin, handicap, sex, age, marital status, or sexual orientation in connection with any Bid/Proposal submitted to Cuyahoga County or the performance of any contract resulting from;

(2) That it is and shall be the policy of this Company to provide equal opportunity to all business persons seeking to contact or otherwise interested in contracting with this Company, including various eligible Minority Business Enterprise & Women Business Enterprise (hereinafter "MBE/WBEs");

(3) In connection herewith, I/We acknowledge and warrant that this Company has been made aware of, understands, and agrees to make a Good Faith Effort to solicit MBE/WBEs to do business with this Company;

(4) That the Covenant of Non-Discrimination as made and set forth herein shall be continuing in nature and shall remain in full force and effect without interruption;

(5) That the Covenant of Non-Discrimination as made and set forth herein shall be and are hereby deemed to be made a part of, and incorporated by reference into, any contract or portion thereof which this Company may hereafter obtain; and

(6) That the failure of this Company to satisfactorily discharge any of the Covenant of Non-Discrimination as made and set forth herein shall constitute a material breach of contract entitling Cuyahoga County to declare the contract in default and to exercise any and all applicable rights and remedies, including but not limited to, cancellation of the contract, termination of the contract, suspension and debarment from future contracting opportunities, and withholding and/or forfeiture of compensation due and owing on a contract.

John Doe  
(Original Signature of Company Representative Identified Above)

February 1, 2021  
(Date)

**MBE/WBE SUBCONTRACTOR PARTICIPATION PLAN  
(MUST be submitted for EACH MBE/WBE Subcontractor Proposed)**

(A) TOTAL AMOUNT OF OVERALL CONTRACT BID/PROPOSAL \$ 500,000.00

BUSINESS NAME OF PRIME BIDDER ABC COMPANY, INC

ADDRESS 111 MAIN STREET

CITY ANYWHERE STATE OHIO ZIP CODE 44000

TELEPHONE ( 216 ) 555-5555 E-MAIL ABCCOMPANY@YAHOO.COM

PRIME FIRM OWNED BY: NON-MBE/WBE/SBE  SBE SMALL BUSINESS ENTERPRISE   
 MBE MINORITY BUSINESS ENTERPRISE  WBE WOMEN BUSINESS ENTERPRISE

(B) AMOUNT TO BE SUBCONTRACTED TO MBE/WBE (PLEASE CIRCLE ONE): \$ 50,000.00 PERCENT OF TOTAL OVERALL CONTRACT BID [(B)/(A)]: 10 %

SCOPE OF WORK PROVIDED BY MBE/WBE: ELECTRICAL CONTRACTING SERVICES

PRIME BIDDER'S NAME JOHN DOE TITLE PRESIDENT/OWNER  
 (TYPE OR PRINT)

PRIME BIDDER'S SIGNATURE JOHN DOE FEBRUARY 1, 2021  
 (DATE OF SIGNATURE)

**MBE/WBE SUBCONTRACTOR TO BE UTILIZED  
(MUST BE CERTIFIED BY THE CUYAHOGA COUNTY DEPARTMENT OF EQUITY AND INCLUSION)**

NAME OF SUBCONTRACTOR ELECTRIFYING ELECTRIC COMPANY

ADDRESS 456 MAIN STREET

CITY ANYWHERE STATE OHIO ZIP CODE 44000

TELEPHONE AREA CODE ( 216 ) 555-5551 X SMALL BUSINESS  MINORITY BUSINESS  WOMEN BUSINESS   
 SBE MBE WBE

**\*\*\*\*\*NOTE MUST BE A COUNTY CERTIFIED MBE/WBE\*\*\*\*\***

THE UNDERSIGNED HERewith AGREES TO SUBCONTRACT WITH THE ABOVE NAMED BIDDER FOR THE ABOVE SAID SERVICE(S) OR SUPPLY(IES) TO BE FURNISHED TO THE COUNTY.

SUBCONTRACTOR'S NAME TOM EDISON TITLE PRESIDENT/OWNER  
 (TYPE OR PRINT)

SUBCONTRACTOR'S SIGNATURE TOM EDISON FEBRUARY 1, 2021  
 (DATE OF SIGNATURE)

### GOOD FAITH EFFORT CERTIFICATION

(Must be submitted with bids NOT meeting Diversity goal or requesting full or partial waiver)

Pursuant to the requirements for bidders under the MBE/WBE Program, and in consideration of the privilege to submit bids/proposals funded, in whole or in part, by Cuyahoga County,

I/We, ( John Doe ), ( President, Owner ) of ( ABC Company, Inc. )  
Name(s) of Person(s) Signing Below Title(s) Company Name

attest that I/We have exercised the following good faith efforts in addition to my/our regular and customary solicitation process: (Check ALL that apply and complete as indicated)

- x I/We are requesting a FULL/PARTIAL WAIVER of the MBE/WBE Participation Goal for the following reason(s): We are requesting a partial waiver of the SBE Goal as we were only able to meet 10% of the 15% goal. But we are able to meet the MBE and WBE goal We were unable to find an SBE to meet the additional 5% required.
- I/We are a non-profit agency and are requesting a FULL WAIVER of the MBE/WBE Participation Goal. **(MUST SUBMIT/ATTACH PROOF)**
- x I/We have contacted DEI or website to obtain a list of the Diversity listing to appropriate to the bid/proposal.
- x I/We delivered written notice to available certified MBE/WBEs for each potential subcontracting or supply category in the contract AND all potential subcontractors or vendors which requested information on the contract. **(MUST SUBMIT/ATTACH PROOF)**
- x I/We have provided all potential subcontractors or vendors with adequate information as to plans, specifications, relevant terms and conditions of the contract, bonding requirements, and the last date and time for receipt of price quotations. **(MUST SUBMIT/ATTACH PROOF)**
- x I/We have attended the pre-bid/proposal conference.
- x I/We have **provided a written explanation for rejection of any potential** MBE/WBE subcontractor or vendor to DEI. When the MBE/WBE subcontractor rejection is due to unreasonably high pricing, I/We have provided supporting documentation.
- x I/We have actively solicited, through sending letters, emails or initiating personal contact, MBE/WBEs in all feasible and appropriate categories providing subcontracting opportunities for the contract under consideration. **(MUST SUBMIT/ATTACH PROOF)**
- x I/We have utilized the services of available community organizations and associations, contractors' groups, and trade associations known to publicize contracting and procurement opportunities, for the purpose of obtaining assistance in the contacting and recruitment of MBE/WBEs for the Cuyahoga County contract under consideration. **(MUST SUBMIT/ATTACH PROOF)**
- x I/We have conducted discussions with interested MBE/WBEs in good faith and provided the same willingness to assist SBEs as has been extended to any other similarly situated subcontractor.
- x I/We have taken steps to ensure that all labor supervisors, superintendents, and other on-site supervisory personnel are aware of and carry out the obligation to maintain a non-discriminatory work environment, free of harassment, intimidation and coercion at all construction sites, offices and other facilities to which employees are assigned to work.

If applicable, identify all MBE/WBEs contacted to participate that declined or were not chosen:

1. Perfect Plumbing Company 222 Main Street, Anywhere, OH 44000 216-555-5553  
Name of Subcontractor/Vendor Address Phone  
Paul Perfect January 15, 2021 \$25,000 (5%) January 18, 2021  
Name of Contact Date of Offer to Participate Bid Amount Date Offer Declined

Reasons Given for Declining Has other commitments at this time and is unable to work with us.

2. Dan's DuctWork Company 333 Main Street, Anywhere, OH 44000 216-555-5554  
Name of Subcontractor/Vendor Address Phone  
Dan Handy January 18, 2021 \$25,000 (5%) January 19, 2021  
Name of Contact Date of Offer to Participate Bid Amount Date Offer Declined

Reasons Given for Declining They are no longer providing the required sub-contracting service as part of its business.

3. Dave's Landscapes Inc 444 Main Street, Anywhere, OH 44000 216-555-5556  
Name of Subcontractor/Vendor Address Phone  
Dave Curbappel January 16, 2021 \$25,000 (5%) January 17, 2021  
Name of Contact Date of Offer to Participate Bid Amount Date Offer Declined

Reasons Given for Declining Has other commitments at this time and is unable to work with us.

(Make additional copies to extend list of MBE/WBE contacts if needed)

I/We affix my/our signature to this document to attest that I/We have exercised the above-indicated Good Faith Efforts to promote Diversity participation on the Bid/Proposal and Contract under consideration and to comply fully with the provisions of the Cuyahoga County MBE/WBE Program.

John Doe  
Printed/Typed Name of Company Official

February 1, 2021  
Date

John Doe  
Signature (Must be Original)

President, Owner  
Title of Company Official

ABC Company, Inc.  
Full Company Name

111 Main Street  
Mailing Address

216-555-5555  
Area Code/ Phone Number

Anywhere, OH 44000  
City, State, Zip

Nancy Notarious  
Notary Public

December 31, 2023  
My Commission Expires

---

PLEASE NOTE: Failure to properly complete and submit **DIV-1, DIV-2, and DIV-3 (if applicable)** will result in **bids/proposals being ruled non-responsive.**

DRAFT