

LEGEND

- L = APPROACH SLAB LENGTH
- W = APPROACH SLAB WIDTH
- T = APPROACH SLAB THICKNESS
- P = APPROACH PAVEMENT THICKNESS
- CCECD = CUYAHOGA COUNTY ENGINEER CONSTRUCTION DRAWING
- CLR. = CLEAR
- MIN. = MINIMUM
- ODOT = OHIO DEPARTMENT OF TRANSPORTATION
- STD. = STANDARD
- TYP. = TYPICAL

NOTES:

- THE FOUR-INCH (4") MINIMUM AGGREGATE BASE AND SUBGRADE GEOTEXTILE FABRIC BENEATH THE APPROACH SLAB SHALL BE OF THE SAME MATERIALS AS THOSE SPECIFIED FOR THE APPROACH PAVEMENT. ALL MATERIAL AND LABOR COSTS ASSOCIATED WITH THE INSTALLATION OF THE FOUR-INCH AGGREGATE BASE, SUBGRADE GEOTEXTILE FABRIC (WHERE SPECIFIED) AND THE SUBGRADE COMPACTION (ITEM 204) SHALL BE MEASURED AND PAID FOR SEPARATELY PER THE PERTINENT CONTRACT ITEM.
- PRESSURE RELIEF JOINTS, TYPE B PER CUYAHOGA COUNTY ENGINEER CONSTRUCTION DRAWING BP-2.4C (EXCEPT AS MODIFIED HEREIN), ARE TO BE PROVIDED REGARDLESS OF ABUTMENT DESIGN AT ALL BRIDGE APPROACHES WHERE APPROACH PAVEMENT IS RIGID OR COMPOSITE CONSISTING OF A RIGID BASE. ALL MATERIAL AND LABOR ASSOCIATED WITH THE TYPE B PRESSURE RELIEF JOINTS, INCLUDING THE SLEEPER SLABS AND UNDERDRAINS, SHALL BE INCLUDED WITH "ITEM SPECIAL - PRESSURE RELIEF JOINT, CUYAHOGA COUNTY, TYPE B" FOR PAYMENT.
- THE CURB PLATE SHALL BE DESIGNED PER CUYAHOGA COUNTY ENGINEER CONSTRUCTION DRAWING CP-1C.
- THE APPROACH SLAB SHALL BE DESIGNED PER ODOT STANDARD DRAWING AS-1-15.
- THE POROUS BACKFILL MATERIAL SHALL BE LIMITED TO STONE AND INCLUDED FOR PAYMENT UNDER ITEM 518, AS PER PLAN.

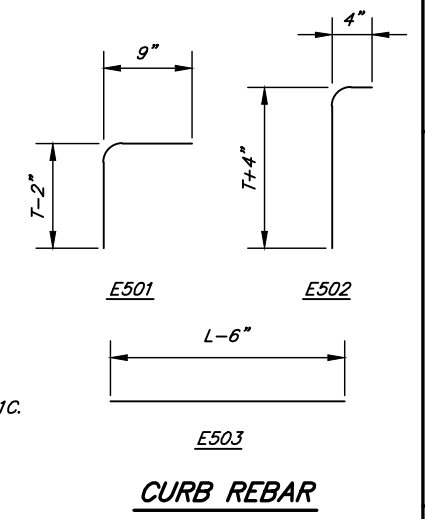

Plot Scale: 1:2 (Half-Size)