

CURB PLATE ELEVATION

(ALL DIMENSIONS MEASURED ALONG THE FACE OF THE CURB PLATE)

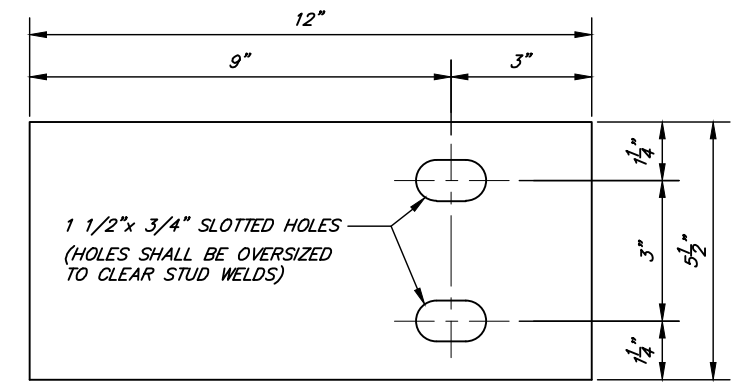

SPLICE PLATE DETAIL

NOTES:

1. ALL CURB PLATE AND SPLICE PLATE STEEL SHALL BE A572 OR A709, GRADE 50 AND SHALL BE GALVANIZED PER 711.02 OR METALIZED PER 516.03 (AND ALSO PAINTED IF SPECIFIED IN THE PROJECT PLANS).
2. ALL STUD ANCHORS, SPLICE PLATES AND THREADED STUDS SHALL BE WELDED TO THE CURB PLATES PRIOR TO GALVANIZING OR METALIZING THE CURB PLATE ASSEMBLY.
3. THE AREAS OF THE FIELD SPLICE WELDS SHALL BE METALIZED TO MAINTAIN THE INTEGRITY OF THE CORROSION PROTECTION OF THE STEEL CURB PLATE.
4. ANY INCIDENTAL DAMAGE TO THE GALVANIZED OR METALIZED COATING SHALL BE REPAIRED PER 516.03 IN THE FIELD AT NO ADDITIONAL COST TO THE PROJECT.

5. A SILICONE SEALANT (e.g., DOW CORNING SL PARKING STRUCTURE SEALANT WITH DOW CORNING 1200 PRIME COAT, BONDAFLEX SIL 728 SL WITH BONDAFLEX SIL 2000 PRIMER, SIKASIL-728 SL WITH SIKASIL PRIMER-2100, OR EQUAL) SHALL BE USED TO SEAL THE JOINT BETWEEN THE BOTTOM EDGE OF THE CURB PLATE AND THE TOP SURFACE OF THE CONCRETE BRIDGE DECK OR APPROACH SLAB TO ENSURE A WATERTIGHT SEAL BETWEEN THE STEEL AND THE CONCRETE.
6. ALL COSTS FOR THE STEEL CURB PLATE, STUD ANCHORS, SPLICES, GALVANIZED OR METALIZED COATING, SILICONE SEALANT AND ALL OTHER INCIDENTALS AND LABOR REQUIRED FOR THE INSTALLATION OF THE CURB PLATE ON THE BRIDGE AND APPROACH SLABS SHALL BE INCLUDED FOR PAYMENT UNDER ITEM 513-STRUCTURAL STEEL MEMBERS, LEVEL UF.

LEGEND

c/c = CENTER TO CENTER
TYP. = TYPICAL

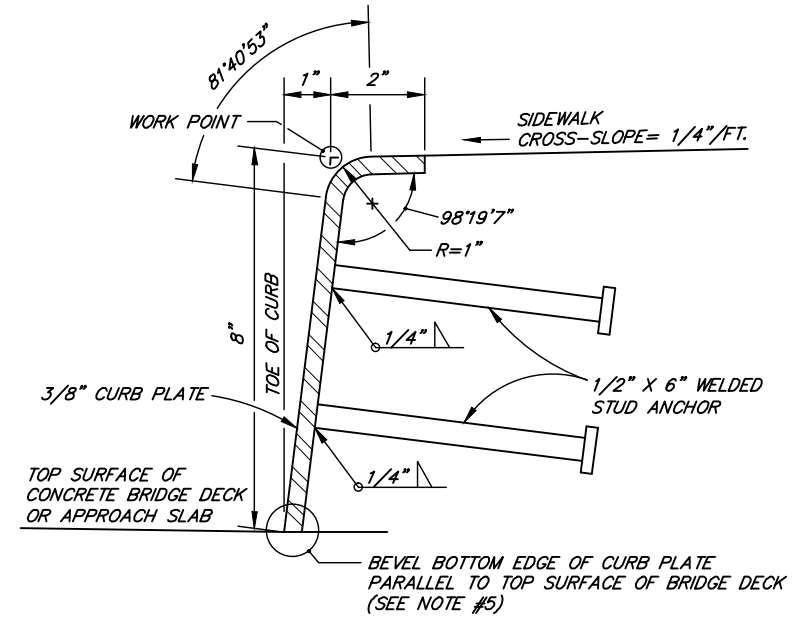

SECTION A-A

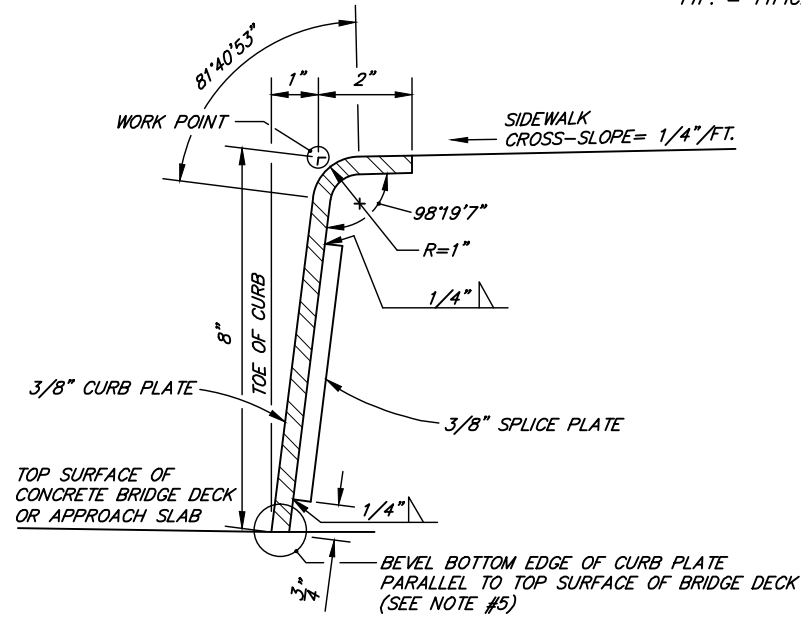

SECTION B-B

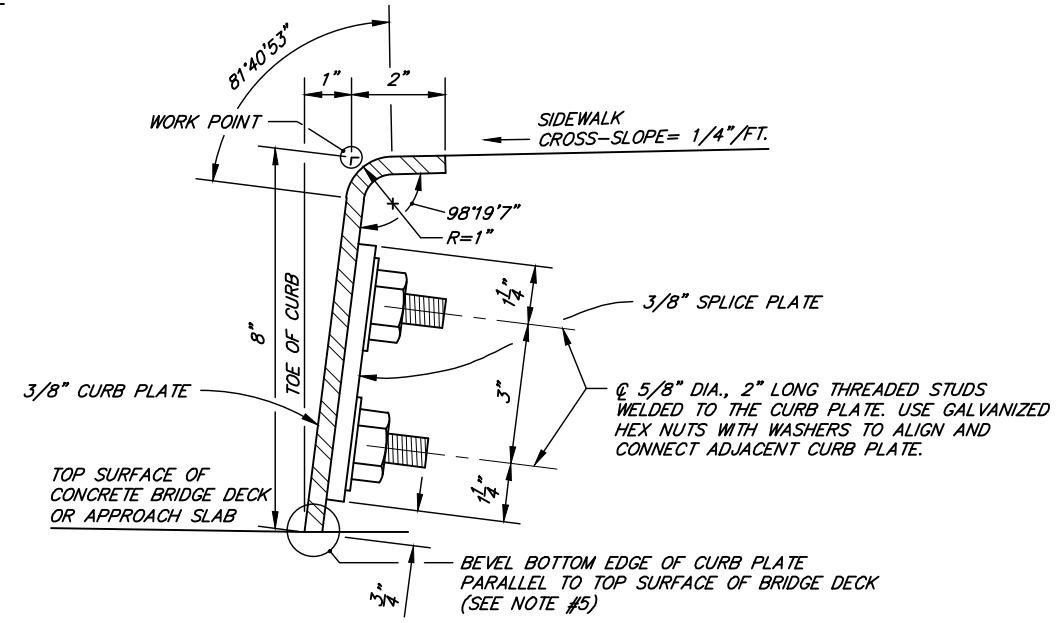

SECTION C-C

Plot Scale: 1:2 (Half-Size)