

PLAN OF COVER

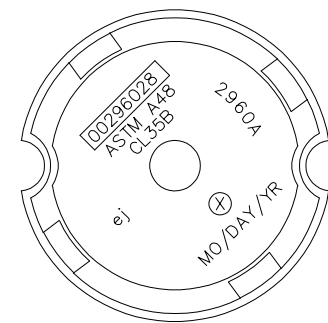

BOTTOM VIEW

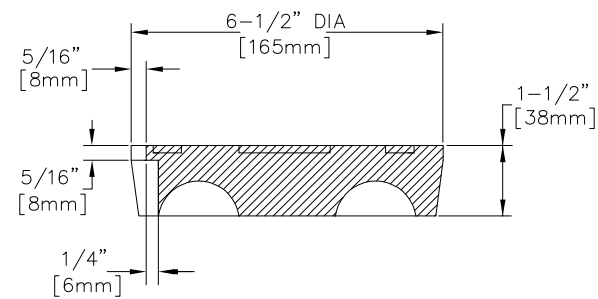

SIDE VIEW OF COVER

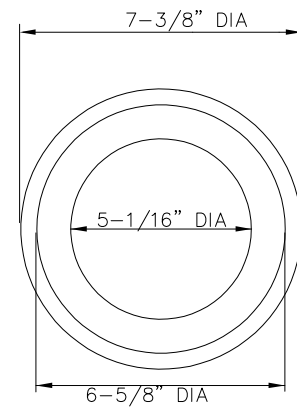

PLAN OF FRAME

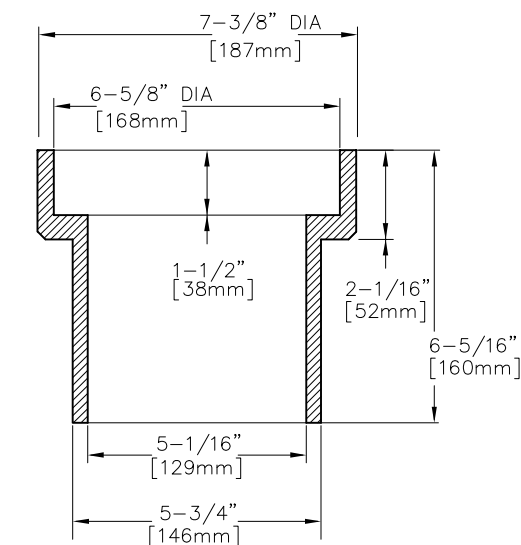

FRAME SECTION

MONUMENT BOX

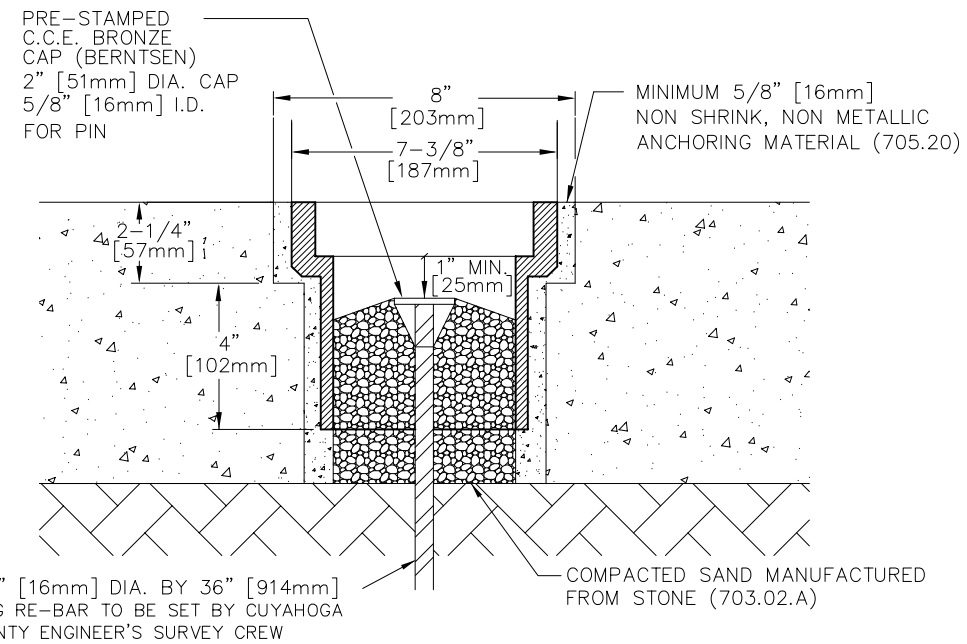

CENTERLINE MONUMENT BOX ASSEMBLY, TYPE 2

(NOT TO BE USED IN LANDSCAPE ISLANDS)

NOTES:

MONUMENT BOX CASTING TO BE EJ 2960Z FRAME WITH SPECIAL ORDER LID 2960A. ANNULAR SPACE BETWEEN CASTING AND PAVEMENT TO BE FILLED WITH NON SHRINK, NON METALLIC ANCHORING MATERIAL PER O.D.O.T. 705.20.

INSTALLATION:

1. CORE BOTH OPENINGS IN PAVEMENT
2. REMOVE DEBRIS AND PREPARE CONCRETE FOR 705.20 ANCHORING MATERIAL PER MANUFACTURER SPECIFICATIONS.
3. COAT PAVEMENT OPENING AND EXTERIOR OF CASTING WITH 705.20 ANCHORING MATERIAL.
4. INSTALL CASTING AND FINISH FLUSH WITH PAVEMENT.

NOTES:

CASTINGS

SHALL MINIMALLY MEET THE REQUIREMENTS OF 611.02.G - 711.12, A.S.T.M. A48, AND MINIMALLY BE CLASS 35B GRAY IRON.

THE ASSEMBLY SHALL BE ESSENTIALLY THE SAME AND EQUALLY AS STRONG AS THOSE SHOWN HEREON.

TOTAL MINIMUM WEIGHT = 22 LBS. (10kg)

PROVIDED THEY COMPLY WITH THE SPECIFICATIONS, DETAILS, DIMENSIONS AND MINIMUM WEIGHT,



EAST JORDAN (EJ)- 2960A MONUMENT BOX COVER
EAST JORDAN (EJ)- 2960Z FRAME SECTION

OR APPROVED EQUAL CASTINGS ARE ACCEPTABLE.

PAY ITEM:

ITEM 623-CUYAHOGA COUNTY CENTERLINE MONUMENT BOX ASSEMBLY, TYPE 2.

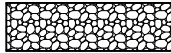
LEGEND:

-  NEW CONCRETE PAVEMENT (451 OR 452)
-  COMPACTED SAND MANUFACTURED FROM STONE (703.02.A)
-  UNDISTURBED EARTH OR AGGREGATE BASE. REPLACEMENT OF UNSUITABLE MATERIAL PER 611.05 & 611.06 AND TO THE SATISFACTION OF THE ENGINEER.

CUYAHOGA COUNTY ENGINEER

TYPE 2 CENTERLINE MONUMENT BOX ASSEMBLY

DATE
07-14-03
06-27-05
08-08-05
08-28-07
10-10-08
10-31-13
11-15-17
12-02-19
03-01-21

CONSTRUCTION DRAWING MB-2C

