

PLAN VIEW

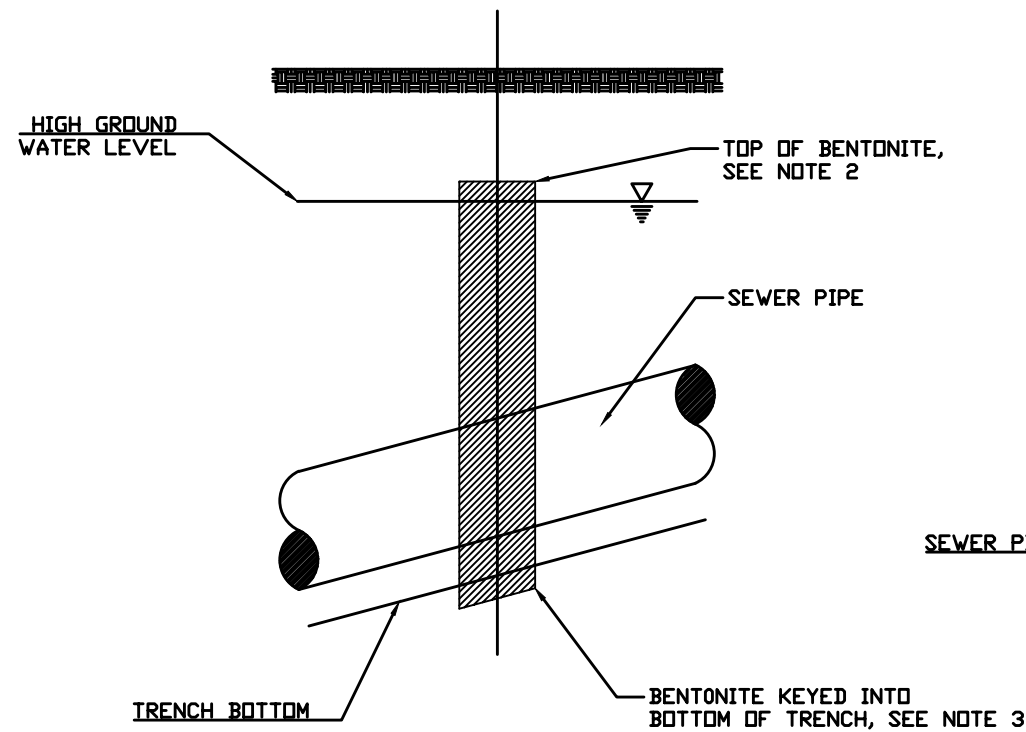

SIDE VIEW PROFILE

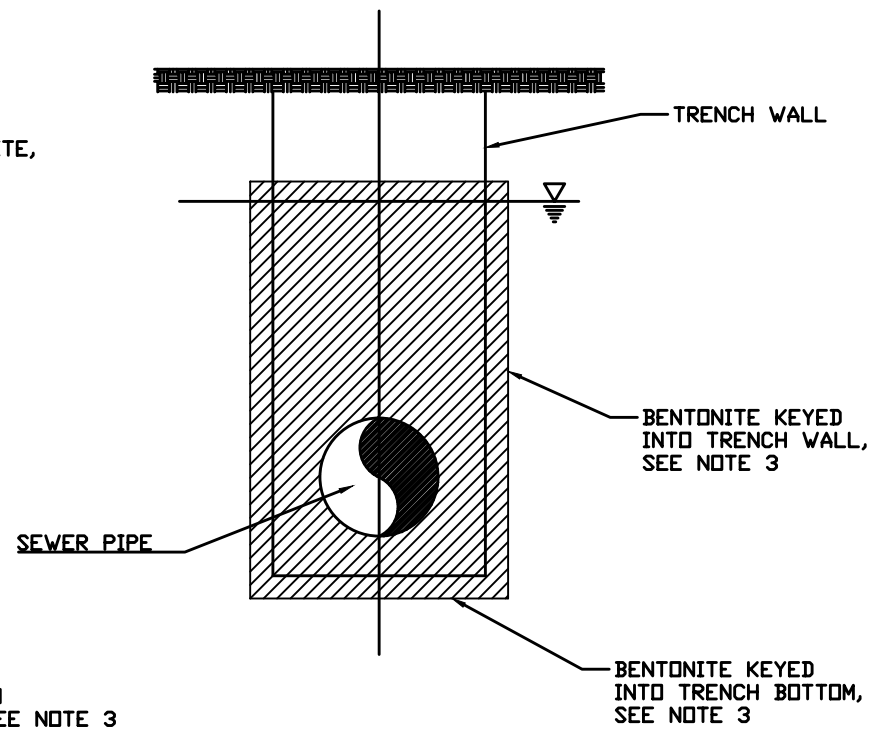

SECTION A-A

NOTES:

- 1) BENTONITE DAM SHALL HAVE A THICKNESS OF 18" ON PIPES 8" AND LARGER, 12" THICKNESS ON 6" AND SMALLER.
- 2) BENTONITE CLAY DAM SHALL EXTEND A MINIMUM OF 1 FOOT ABOVE THE PIPE AND SHALL EXCEED THE HEIGHT OF THE HIGH GROUND WATER LEVEL BY 6" AND AS DETERMINED BY THE SEWER INSPECTOR.
- 3) KEYED IN SECTIONS SHALL BE A MINIMUM OF 6" AND SHALL BE BOUNDED BY UNDISTURBED TRENCH WALL SOILS.
- 4) THE BENTONITE CLAY DAM LIMITS SHALL BE FREE AND CLEAR OF ANY PIPE BEDDING AND PREMIUM BACKFILL MATERIAL AND SHALL CONSIST OF ONLY BENTONITE.
- 5) THE BENTONITE MATERIAL SHALL BE CETCO MX-80 OR APPROVED EQUAL.

BENTONITE CLAY DAM DETAIL

REVISIONS:

SCALE
NO SCALE

DATE: OCTOBER 2021